



## Leitor Zebra MS3207

O MiniScan Symbol MS3207 oferece um padrão exclusivo de leitura omnidirecional em alta velocidade, para ler de forma rápida e precisa os símbolos minimizando a necessidade de posicionamento preciso de códigos de barras lineares 1D.



# ***MiniScan MS-320X Integration Guide***

72-58810-02

*Revision A*

*October 2003*



© 2003 by Symbol Technologies, Inc. All rights reserved.

No part of this publication may be reproduced or used in any form, or by any electrical or mechanical means, without permission in writing from Symbol. This includes electronic or mechanical means, such as photocopying, recording, or information storage and retrieval systems. The material in this manual is subject to change without notice.

The software is provided strictly on an “as is” basis. All software, including firmware, furnished to the user is on a licensed basis. Symbol grants to the user a non-transferable and non-exclusive license to use each software or firmware program delivered hereunder (licensed program). Except as noted below, such license may not be assigned, sublicensed, or otherwise transferred by the user without prior written consent of Symbol. No right to copy a licensed program in whole or in part is granted, except as permitted under copyright law. The user shall not modify, merge, or incorporate any form or portion of a licensed program with other program material, create a derivative work from a licensed program, or use a licensed program in a network without written permission from Symbol. The user agrees to maintain Symbol’s copyright notice on the licensed programs delivered hereunder, and to include the same on any authorized copies it makes, in whole or in part. The user agrees not to decompile, disassemble, decode, or reverse engineer any licensed program delivered to the user or any portion thereof.

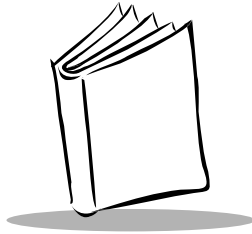
Symbol reserves the right to make changes to any software or product to improve reliability, function, or design.

Symbol does not assume any product liability arising out of, or in connection with, the application or use of any product, circuit, or application described herein.

No license is granted, either expressly or by implication, estoppel, or otherwise under any Symbol Technologies, Inc., intellectual property rights. An implied license only exists for equipment, circuits, and subsystems contained in Symbol products.

Symbol, Spectrum One, and Spectrum24 are registered trademarks of Symbol Technologies, Inc. Other product names mentioned in this manual may be trademarks or registered trademarks of their respective companies and are hereby acknowledged.

Symbol Technologies, Inc.  
One Symbol Plaza  
Holtsville, New York 11742-1300  
<http://www.symbol.com>



# Contents

## About This Manual

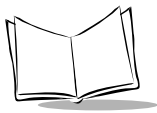
Chapter Descriptions .....	.xi
Notational Conventions .....	xii
Related Documents .....	xii
Service Information .....	xii
Symbol Support Center .....	xiii

## Chapter 1. Introduction

Overview .....	1-1
MiniScan MS-320X Features .....	1-2
Typical Applications .....	1-2
Block Diagram .....	1-3
Scanning Patterns .....	1-5
Smart Raster Scan Pattern .....	1-5
Semi-omnidirectional Scan Pattern .....	1-6
Omnidirectional Scan Pattern .....	1-6
High Density Single Scan Line .....	1-7
Beeper and LED Definitions .....	1-8

## Chapter 2. Installation

Overview .....	2-1
Unpacking .....	2-1
Mounting .....	2-2
Mounting the Scanner on the Stand (optional) .....	2-3
Assembling the Stand .....	2-3
Mounting the Stand (optional) .....	2-4
Connecting MiniScan .....	2-5
Mechanical Drawing .....	2-7
Location and Positioning .....	2-9



Using the MiniScan as an Embedded Scanner . . . . .	2-9
Conveyor Applications . . . . .	2-12
Accessories . . . . .	2-15
Software Development CD . . . . .	2-16
123Scan CD . . . . .	2-16

### Chapter 3. MS-3204 Specifications

Overview . . . . .	3-1
Electrical Interface . . . . .	3-2
MS-3204 Technical Specifications . . . . .	3-3
MS-3204 Decode Zones . . . . .	3-6
Omnidirectional Decode Distances . . . . .	3-6
2D Slab/Raster Decode Distances (MS-3204-I000 Only) . . . . .	3-8
Usable Scan Length . . . . .	3-9

### Chapter 4. MS-3207 Specifications

Overview . . . . .	4-1
Electrical Interface . . . . .	4-2
MS-3207 Technical Specifications . . . . .	4-4
MS-3207 Decode Zones . . . . .	4-7
Omnidirectional Decode Distances . . . . .	4-7
2D Slab/Raster Decode Distances . . . . .	4-9
Usable Scan Length . . . . .	4-10
Application Notes . . . . .	4-11
TTL RS-232 . . . . .	4-11
USB Warning - Potential host side issues . . . . .	4-11

### Chapter 5. Scanning

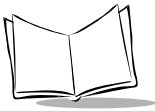
Overview . . . . .	5-1
Scanning Tips . . . . .	5-1
Scan the Entire Symbol . . . . .	5-1
Position at an Angle . . . . .	5-2
Triggering Options . . . . .	5-2
Continuous (Default) . . . . .	5-2
Level Trigger . . . . .	5-2
Pulse Trigger . . . . .	5-3
Blinking . . . . .	5-3
Host Trigger (MS-3204 Only) . . . . .	5-3

## Chapter 6. Maintenance and Troubleshooting

Overview .....	6-1
Maintenance .....	6-1
Troubleshooting .....	6-1

## Chapter 7. Parameter Menus

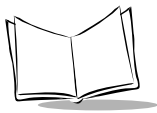
Operational Parameters .....	7-1
Default Table .....	7-2
Set Default Parameter .....	7-11
Scanning Options .....	7-12
Beeper Volume .....	7-12
Beeper Tone .....	7-13
Beeper Frequency Adjustment .....	7-14
Laser On Time .....	7-15
Power Mode .....	7-16
Triggering Modes .....	7-17
Scanning Mode .....	7-19
Aiming Mode .....	7-20
Programmable Raster Height And Raster Expansion Speed .....	7-21
Timeout Between Decodes .....	7-22
Beep After Good Decode .....	7-23
Transmit "No Read" Message .....	7-24
Parameter Scanning .....	7-25
Linear Code Type Security Level .....	7-26
Bi-directional Redundancy .....	7-28
UPC/EAN .....	7-29
Enable/Disable UPC-A .....	7-29
Enable/Disable UPC-E .....	7-30
Enable/Disable UPC-E1 .....	7-31
Enable/Disable EAN-8 .....	7-32
Enable/Disable EAN-13 .....	7-33
Enable/Disable Bookland EAN .....	7-34
UPC/EAN Coupon Code .....	7-35
Decode UPC/EAN Supplementals .....	7-36
Decode UPC/EAN Supplemental Redundancy .....	7-38
Transmit UPC-A Check Digit .....	7-39
Transmit UPC-E Check Digit .....	7-40
Transmit UPC-E1 Check Digit .....	7-41
UPC-A Preamble .....	7-42
UPC-E Preamble .....	7-43
UPC-E1 Preamble .....	7-44
Convert UPC-E to UPC-A .....	7-45



Convert UPC-E1 to UPC-A	7-46
EAN Zero Extend	7-47
UPC/EAN Security Level	7-48
Linear UPC/EAN Decode	7-50
Code 128	7-51
Enable/Disable Code 128	7-51
Enable/Disable UCC/EAN-128	7-52
Enable/Disable ISBT 128	7-53
Lengths for Code 128	7-53
Code 128 Decode Performance	7-54
Code 128 Decode Performance Level	7-55
Code 39	7-56
Enable/Disable Code 39	7-56
Enable/Disable Trioptic Code 39	7-57
Convert Code 39 to Code 32	7-58
Code 32 Prefix	7-59
Set Lengths for Code 39	7-60
Code 39 Check Digit Verification	7-62
Transmit Code 39 Check Digit	7-63
Enable/Disable Code 39 Full ASCII	7-64
Code 39 Decode Performance	7-65
Code 39 Decode Performance Level	7-66
Code 93	7-67
Enable/Disable Code 93	7-67
Set Lengths for Code 93	7-68
Code 11	7-70
Enable/Disable Code 11	7-70
Set Lengths for Code 11	7-71
Code 11 Check Digit Verification	7-73
Transmit Code 11 Check Digit	7-74
Interleaved 2 of 5	7-75
Enable/Disable Interleaved 2 of 5	7-75
Set Lengths for Interleaved 2 of 5	7-76
I 2 of 5 Check Digit Verification	7-78
Transmit I 2 of 5 Check Digit	7-79
Convert I 2 of 5 to EAN-13	7-80
Discrete 2 of 5	7-81
Enable/Disable Discrete 2 of 5	7-81
Set Lengths for Discrete 2 of 5	7-82
Codabar	7-84
Enable/Disable Codabar	7-84
Set Lengths for Codabar	7-85
CLSI Editing	7-87
NOTIS Editing	7-88

MSI Plessey	7-89
Enable/Disable MSI Plessey	7-89
Set Lengths for MSI Plessey	7-90
MSI Plessey Check Digits	7-92
Transmit MSI Plessey Check Digit	7-93
MSI Plessey Check Digit Algorithm	7-94
PDF417/MicroPDF417	7-95
Enable/Disable PDF417	7-95
Enable/Disable MicroPDF417	7-96
MicroPDF Performance	7-97
Code 128 Emulation	7-98
RSS Codes	7-99
RSS-14	7-99
RSS-Limited	7-100
RSS-Expanded	7-101
Composite (MS-3204 Only)	7-102
Composite CC-C	7-102
Composite CC-A/B	7-103
Composite TLC-39	7-104
UPC Composite Mode	7-105
Data Options	7-106
Transmit Code ID Character	7-106
Prefix/Suffix Values	7-108
Scan Data Transmission Format (MS-3204)	7-110
Scan Data Transmission Format (MS-3207)	7-112
Simple Serial Interface (SSI) Options (MS-3204 Only)	7-114
Baud Rate	7-114
Parity	7-116
Check Parity	7-118
Software Handshaking	7-119
Host RTS Line State	7-120
Decode Data Packet Format	7-121
Stop Bit Select	7-122
Intercharacter Delay	7-123
Host Serial Response Time-out	7-123
Host Character Time-out	7-124
Event Reporting	7-124
Decode Event	7-125
Boot Up Event	7-126
Parameter Event	7-127
Macro PDF Features	7-128
Transmit Symbols in Codeword Format	7-128
Transmit Unknown Codewords	7-130
Escape Characters	7-131





Delete Character Set ECIs . . . . .	7-132
ECI Decoder . . . . .	7-133
Transmit Macro PDF User-Selected Fields . . . . .	7-134
Transmit File Name . . . . .	7-134
Transmit Block Count . . . . .	7-135
Transmit Time Stamp . . . . .	7-136
Transmit Sender . . . . .	7-137
Transmit Addressee . . . . .	7-138
Transmit Checksum . . . . .	7-139
Transmit File Size . . . . .	7-140
Transmit Macro PDF Control Header . . . . .	7-141
Last Blocker Marker . . . . .	7-142
Numeric Bar Codes . . . . .	7-143
Cancel . . . . .	7-145

## Chapter 8. RS-232 Interface (MS-3207 Only)

Introduction . . . . .	8-1
RS-232 Default Parameters . . . . .	8-2
RS-232 Host Parameters . . . . .	8-4
RS-232 Host Types . . . . .	8-6
Baud Rate . . . . .	8-8
Parity . . . . .	8-10
Stop Bit Select . . . . .	8-12
Data Bits . . . . .	8-12
Check Receive Errors . . . . .	8-13
Hardware Handshaking . . . . .	8-14
Software Handshaking . . . . .	8-16
Host Serial Response Time-out . . . . .	8-19
RTS Line State . . . . .	8-20
Beep on <BEL> . . . . .	8-20
Intercharacter Delay . . . . .	8-21
Nixdorf Beep/LED Options . . . . .	8-22
Ignore Unknown Characters . . . . .	8-23

## Chapter 9. USB Interface (MS-3207 Only)

Introduction . . . . .	9-1
Connecting a USB Interface . . . . .	9-2
USB Default Parameters . . . . .	9-3
USB Host Parameters . . . . .	9-4
USB Device Type . . . . .	9-4
USB Country Keyboard Types (Country Codes) . . . . .	9-5
USB Keystroke Delay . . . . .	9-8

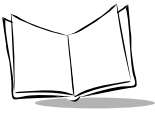
USB CAPS Lock Override .....	9-9
USB Ignore Unknown Characters .....	9-10
Emulate Keypad .....	9-11
USB Keyboard FN 1 Substitution .....	9-11
Function Key Mapping .....	9-12
Simulated Caps Lock .....	9-12
Convert Case .....	9-13

## Chapter 10. 123Scan (MS-3207 Only)

Introduction .....	10-1
Communication With the 123Scan PC Based Configuration Tool .....	10-1
123Scan Parameter .....	10-2

## Chapter 11. Advanced Data Formatting (MS-3207 Only)

Introduction .....	11-1
Rules: Criteria Linked to Actions .....	11-1
Using ADF Bar Codes .....	11-2
ADF Bar Code Menu Example .....	11-3
Rule 1: The Code 128 Scanning Rule .....	11-4
Rule 2: The UPC Scanning Rule .....	11-4
Alternate Rule Sets .....	11-4
Rules Hierarchy (in Bar Codes) .....	11-6
Default Rules .....	11-7
Special Commands .....	11-8
Pause Duration .....	11-8
Begin New Rule .....	11-8
Save Rule .....	11-9
Erase .....	11-9
Quit Entering Rules .....	11-10
Disable Rule Set .....	11-11
Criteria .....	11-12
Code Types .....	11-12
Code Lengths .....	11-15
Message Containing A Specific Data String .....	11-20
Actions .....	11-24
Send Data .....	11-25
Setup Field(s) .....	11-28
Modify Data .....	11-33
Pad Data with Spaces .....	11-35
Pad Data with Zeros .....	11-39
Beeps .....	11-43
Send Keystroke (Control Characters and Keyboard Characters) .....	11-44



Send Right Control Key . . . . .	11-74
Send Graphic User Interface (GUI) Characters . . . . .	11-74
Turn On/Off Rule Sets . . . . .	11-81
Alphanumeric Keyboard . . . . .	11-82

## **Chapter 12. Simple Serial Interface (SSI) (MS-3204 Only)**

Simple Serial Interface (SSI) . . . . .	12-1
Revision String . . . . .	12-2
SSI Commands Not Supported . . . . .	12-2

## **Chapter 13. Mounting Template**

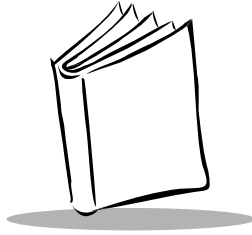
Overview . . . . .	13-1
--------------------	------

## **Appendix A. ASCII Character Set**

RS-232 ASCII Character Set . . . . .	A-1
USB ASCII Character Set . . . . .	A-7

## **Glossary**

## **Index**



## About This Manual

The *MiniScan MS-320X Integration Guide* provides general instructions for mounting, setting up, and programming the MiniScan MS-320X.

---

**Note:** *It is recommended that an opto-mechanical engineer perform an opto-mechanical analysis prior to integration.*

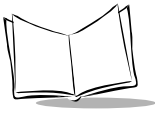
---

## Chapter Descriptions

---

Topics covered in this guide are as follows:

- **Chapter 1, Introduction**, provides an overview of the MS-320X scanner, and explains the theory of operation.
- **Chapter 2, Installation**, describes the mechanical, electrical, optical and other environments related to installing the MS-320X scanner.
- **Chapter 3, MS-3204 Specifications**, provides the technical and scanning specifications for the MS-3204-I000 scanner.
- **Chapter 4, MS-3207 Specifications**, provides the technical and scanning specifications for the MS-3207-I000 scanner.
- **Chapter 5, Scanning**, provides information on scanning and trigger modes.
- **Chapter 6, Maintenance and Troubleshooting** provides information on maintaining and troubleshooting the MS-320X scanner.
- **Chapter 7, Parameter Menus** describes the programmable parameters, provides bar codes for programming, and hexadecimal equivalents for host download programming.
- **Chapter 8, RS-232 Interface (MS-3207 Only)** provides information for setting up the scanner for RS-232 operation.



- **Chapter 9, USB Interface (MS-3207 Only)** provides information for setting up the scanner for USB operation.
- **Chapter 10, 123Scan (MS-3207 Only)** describes the 123Scan program, a PC based scanner configuration tool.
- **Chapter 11, Advanced Data Formatting (MS-3207 Only)** (ADF) describes how to customize scanned data before transmitting to the host.
- **Chapter 12, Simple Serial Interface (SSI) (MS-3204 Only)** describes scanner-specific updates to the *Simple Serial Interface (SSI) Programmer's Guide*.
- **Chapter 13, Mounting Template**, provides a mounting template for the MS-320X scanner.
- **Appendix A, ASCII Character Set**, provides prefix and suffix values that can be assigned for ASCII character data transmission.

## Notational Conventions

---

The following conventions are used in this document:

- Bullets indicate:
  - action items
  - lists of alternatives
  - lists of required steps that are not necessarily sequential
- Sequential lists (e.g., those that describe step-by-step procedures) appear as numbered lists.

## Related Documents

---

The following documents provide more information for the MiniScan MS-320X scanners.

- *MiniScan Family of Scanners, Quick Reference Guide*, p/n 72-58809-XX

## Service Information

---

If you have a problem with your equipment, contact the [Symbol Support Center](#). Before calling, have the model number, serial number, and several of your bar code symbols at hand.

Call the Support Center from a phone near the scanning equipment so that the service person can try to talk you through your problem. If the equipment is found to be working

properly and the problem is symbol readability, the Support Center will request samples of your bar codes for analysis at our plant.

If your problem cannot be solved over the phone, you may need to return your equipment for servicing. If that is necessary, you will be given specific directions.

---

**Note:** *Symbol Technologies is not responsible for any damages incurred during shipment if the approved shipping container is not used. Shipping the units improperly can possibly void the warranty. If the original shipping container was not kept, contact Symbol to have another sent to you.*

---

## **Symbol Support Center**

For service information, warranty information or technical assistance contact or call the Symbol Support Center in:

### **United States**

Symbol Technologies, Inc.  
One Symbol Plaza  
Holtsville, New York 11742-1300  
1-800-653-5350

### **United Kingdom**

Symbol Technologies  
Symbol Place  
Winnersh Triangle, Berkshire RG41 5TP  
United Kingdom  
0800 328 2424 (Inside UK)  
+44 118 945 7529 (Outside UK)

### **Australia**

Symbol Technologies Pty. Ltd.  
432 St. Kilda Road  
Melbourne, Victoria 3004  
1-800-672-906 (Inside Australia)  
+61-3-9866-6044 (Outside Australia)

### **Canada**

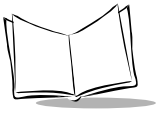
Symbol Technologies Canada, Inc.  
2540 Matheson Boulevard East  
Mississauga, Ontario, Canada L4W 4Z2  
905-629-7226

### **Asia/Pacific**

Symbol Technologies Asia, Inc (Singapore Branch)  
230 Victoria Street #05-07/09  
Bugis Junction Office Tower  
Singapore 188024  
Tel : +65-6796-9600  
Fax : +65-6337-6488

### **Austria/Österreich**

Symbol Technologies Austria GmbH  
Prinz-Eugen Strasse 70 / 2.Haus  
1040 Vienna, Austria  
01-5055794-0 (Inside Austria)  
+43-1-5055794-0 (Outside Austria)



**Denmark/Danmark**

Symbol Technologies AS  
Dr. Neergaardsvej 3  
2970 Hørsholm  
7020-1718 (Inside Denmark)  
+45-7020-1718 (Outside Denmark)

**Finland/Suomi**

Oy Symbol Technologies  
Kaupintie 8 A 6  
FIN-00440 Helsinki, Finland  
9 5407 580 (Inside Finland)  
+358 9 5407 580 (Outside Finland)

**Germany/Deutschland**

Symbol Technologies GmbH  
Waldstrasse 66  
D-63128 Dietzenbach, Germany  
6074-49020 (Inside Germany)  
+49-6074-49020 (Outside Germany)

**Latin America Sales Support**

2730 University Dr.  
Coral Springs, FL 33065 USA  
1-800-347-0178 (Inside United States)  
+1-954-255-2610 (Outside United States)  
954-340-9454 (Fax)

**Europe/Mid-East Distributor Operations**

Contact your local distributor or call  
+44 118 945 7360

**France**

Symbol Technologies France  
Centre d'Affaire d'Antony  
3 Rue de la Renaissance  
92184 Antony Cedex, France  
01-40-96-52-21 (Inside France)  
+33-1-40-96-52-50 (Outside France)

**Italy/Italia**

Symbol Technologies Italia S.R.L.  
Via Cristoforo Colombo, 49  
20090 Trezzano S/N Navigilo  
Milano, Italy  
2-484441 (Inside Italy)  
+39-02-484441 (Outside Italy)

**Mexico/México**

Symbol Technologies Mexico Ltd.  
Torre Picasso  
Boulevard Manuel Avila Camacho No 88  
Lomas de Chapultepec CP 11000  
Mexico City, DF, Mexico  
5-520-1835 (Inside Mexico)  
+52-5-520-1835 (Outside Mexico)

**Netherlands/Nederland**

Symbol Technologies  
Kerkplein 2, 7051 CX  
Postbus 24 7050 AA  
Varsseveld, Netherlands  
315-271700 (Inside Netherlands)  
+31-315-271700 (Outside Netherlands)

**South Africa**

Symbol Technologies Africa Inc.  
Block B2  
Rutherford Estate  
1 Scott Street  
Waverly 2090 Johannesburg  
Republic of South Africa  
11-809 5311 (Inside South Africa)  
+27-11-809 5311 (Outside South Africa)

**Norway/Norge**

Symbol's registered and mailing address:  
Symbol Technologies Norway  
Hoybratenveien 35 C  
N-1055 OSLO, Norway

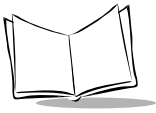
Symbol's repair depot and shipping address:  
Symbol Technologies Norway  
Enebakkveien 123  
N-0680 OSLO, Norway

+47 2232 4375

**Spain/España**

Symbol Technologies S.L.  
Avenida de Bruselas, 22  
Edificio Sauce  
Alcobendas, Madrid 28108  
Spain  
Telephone: +34.91.324.4000  
Service Telephone: +34.91.324.4000  
Fax: +34.91.324.4010





**Sweden/Sverige**

“Letter” address:

Symbol Technologies AB

Box 1354

S-171 26 SOLNA

Sweden

Visit/shipping address:

Symbol Technologies AB

Solna Strandväg 78

S-171 54 SOLNA

Sweden

Switchboard: 08 445 29 00 (domestic)

Call Center: +46 8 445 29 29 (international)

Support E-Mail:

Sweden.Support@se.symbol.com

If you purchased your Symbol product from a Symbol Business Partner, contact that Business Partner for service.

For the latest version of this guide go to:<http://www.symbol.com/manuals>.



# *Chapter 1*

## *Introduction*



### **Caution**

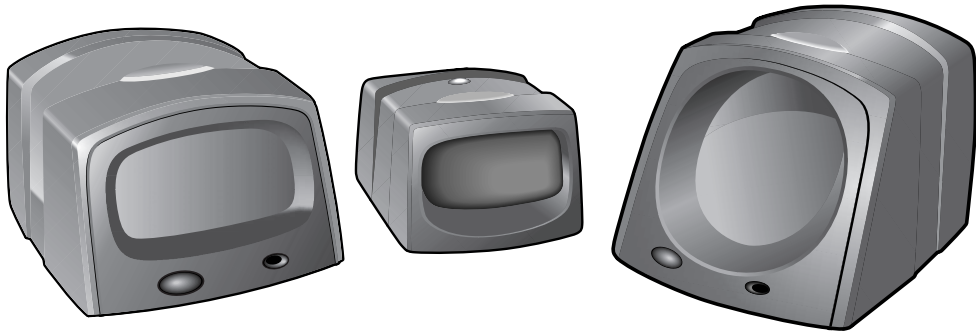
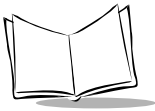
Use of controls, adjustments or procedures other than those specified here can result in hazardous laser light exposure.

## **Overview**

---

The MS-320X is a member of the MiniScan family of fixed-mount scanners specifically designed for stand-alone applications, and OEM applications such as kiosks.

The MS-320X provides easy and flexible integration of bar code scanning into a host device. The MS-320X is a high-performance scanner that offers a unique high-speed omnidirectional scan pattern that reads bar codes quickly and accurately—minimizing the need for precise positioning of linear 1D bar codes. The MS-320X is also capable of reading 2D bar codes such as PDF417 and composite codes.



**Figure 1-1. MiniScan Family of Scanners**

## ***MiniScan MS-320X Features***

- Stand-alone or OEM applications
- Quick and easy integration for OEM devices
- Excellent scanning performance on all types of bar codes
- Rugged IP54 sealed housing with integrated beeper
- RS-232 or multi-interface (USB, Synapse, TTL RS-232)
- Easy programming and configuration
- Flexible mounting options.

## **Typical Applications**

---

MiniScan is the perfect solution for the applications listed below:

### **Fixed Mount Stand alone Applications**

- Manufacturing / Warehouse
- Conveyer belts
- Security / ID verification
- POS.

**OEM Applications**

- Kiosks / ATMs
- Music Listening Stations
- Security / ID Verification
- Lottery terminals / Gaming.

**Block Diagram**

The MiniScan block diagram illustrates the functional relationship of the MiniScan components. A detailed description of each component in the block diagram is also provided.

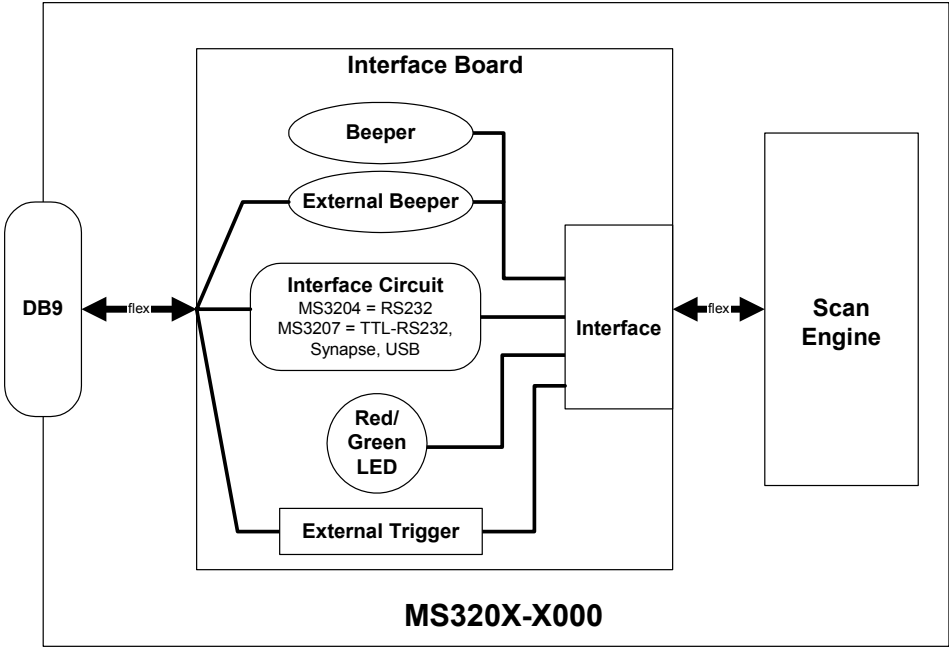
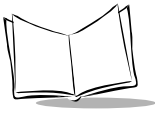


Figure 1-2. MiniScan Block Diagram



## **Miniscan Block Diagram Descriptions**

**Decoded Scan Engine** - The scan engine emits a beam of laser light that reflects off the bar code to be decoded. Black bars absorb light, white spaces reflect light. The scan engine collects the reflected light and processes the signal through several analog filters. The filtered signal is digitized into a Digitized Barcode Pattern (DBP). Timing information is analyzed by the decoder micro-controller to decode and transmit the data contained in the bar code. Data transmission is carried out using Symbol's proprietary SSI Interface.

**Interface Board** - The interface board adapts the scan engine's SSI interface into usable signals and data for the intended host. It also contains a beeper and red/green LED for audio/visual feedback, as well as provisions for an external trigger and external beeper.

- The MS-3204 interface board converts TTL level SSI signals to proper RS-232 levels for connection to any RS-232 compliant host.
- The MS-3207 interface board converts the scan engine's data to Synapse, USB, or TTL level RS-232. A separate host adapter cable (p/n 25-62186-XX) is available to convert the TTL level RS-232 output to standard RS-232 levels. All interface types are auto-detected based on the host cable attached.

**DB9** - The DB9 connector provides a sealed outlet for the various interface signals used between a MiniScan scanner and it's host. It also maintains pin compatibility with the previous generation LS 1220 MiniScan host cables.

## Scanning Patterns

---

The MiniScan generates four scanning patterns based on the software command received at the interface. These patterns are Smart Raster, Semi-omnidirectional, Omnidirectional, and High Density Single Scan Line. The raster pattern can be used to read 1D bar codes and PDF symbols. The omnidirectional pattern reads 1D bar codes in an omnidirectional manner.

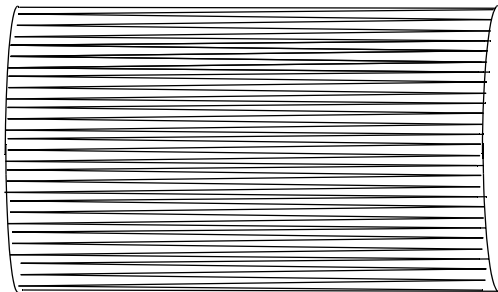
### ***Smart Raster Scan Pattern***

The MS-320x can create a single line which opens vertically to read PDF417 symbols using the Smart Raster feature. This feature auto detects the type of bar code being scanned and adjusts its pattern accordingly, providing optimal performance on 1D, PDF417, RSS, and Composite codes.

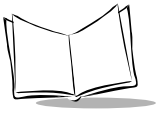
Stage 1: "Slab" Raster Pattern



Stage 2: Open Raster Pattern

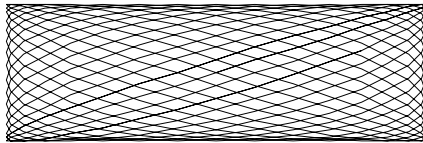


**Figure 1-3. Raster Scan Pattern**



## ***Semi-omnidirectional Scan Pattern***

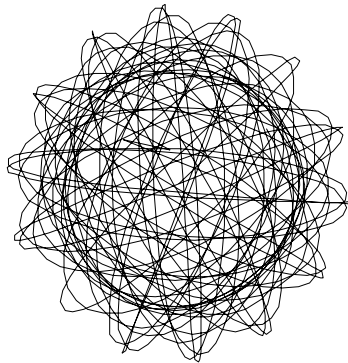
The semi-omnidirectional pattern is an alternative to the full omnidirectional pattern that scans highly truncated 1D and RSS bar codes. Present bar codes horizontally with no more than a 20° tilt.



**Figure 1-4. Semi-omnidirectional Scan Pattern**

## ***Omnidirectional Scan Pattern***

The high-speed rotating Omnidirectional scan pattern provides aggressive performance on 1D bar codes because there are no “holes” in the pattern. This ensures fast throughput at the point of activity and the ability to read 1D symbols in 360° of rotation, eliminating the need to orient the bar code in the field of view.



**Figure 1-5. Omnidirectional Scan Pattern**

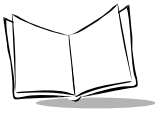
## ***High Density Single Scan Line***

The High Density single scan line appears as a "mini" raster and scans multiple areas of 1D codes to swiftly and accurately capture data on poorly printed and damaged bar codes.



**Figure 1-6. High Density Single Scan Line Scan Pattern**





## Beeper and LED Definitions

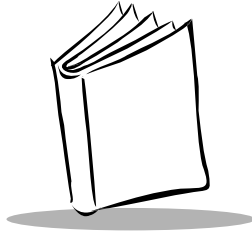
Table 1-1 provides standard beeper definitions, and Table 1-2 provides LED definitions.

**Table 1-1. Standard Beeper Definitions**

Beeper Sequence	Indication
<b>Standard Use</b>	
1 Beep - short high tone	A bar code symbol was decoded (if decode beeper is enabled).
1 Beep - long high tone	Thermal shutdown.
3 Beeps - short high tone	Power-on or reset. Occurs immediately after the unit is turned on, indicating that the system software is working properly. If three beeps occur during normal operation, it is due to a reset and any work in progress is lost. If this occurs often, contact the Symbol Support Center.
<b>Parameter Menu Scanning</b>	
2 Beeps- short high tone	Correct entry scanned or correct menu sequence performed.
1 Beep- hi/lo/hi/lo tone	Successful program exit with change in the parameter setting.
2 Beeps - lo/hi tone	Input error, incorrect bar code, or "Cancel" scanned, wrong entry, incorrect bar code programming sequence; remain in program mode.
<b>Communication</b>	
4 Beeps - short high tone	Communication error.
4 Beeps - hi/hi/hi/lo	Receive error.
3 Beeps - lo/hi/lo	ADF transmit error.

**Table 1-2. LED Definitions**

LED	Indication
Red	Scanner is on.
Green	A bar code was successfully decoded.



## *Chapter 2* *Installation*

### **Overview**

---

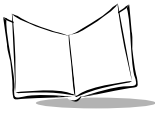
This chapter provides information on unpacking, mounting, and installing the MiniScan, and includes physical and electrical considerations.

### **Unpacking**

---

Remove the MiniScan from its packing and inspect for damage. If the scanner is damaged, call the [Symbol Support Center](#) at the telephone number listed on [page xiii](#).

**KEEP THE PACKING.** It is the approved shipping container and should be used if the equipment needs to be returned for servicing.



## Mounting

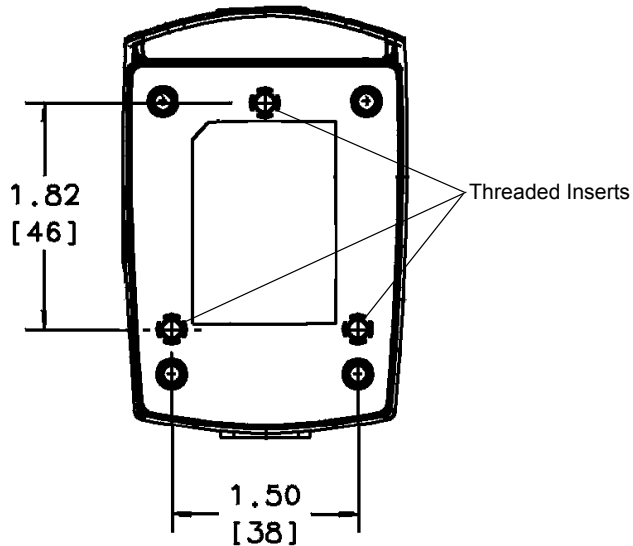
There are three mounting holes (threaded inserts) on the bottom of the chassis.

Figure 2-1 provides mounting dimensions for the MiniScan scanner housing. For a mounting template, see *Mounting Template* on page 13-1.

---

**Note:** Use only non-magnetic M3x.5 screws with a maximum length of 3.6M for mounting the MiniScan scanner chassis.

---



Note:

Dimensions are in inches [mm].

Figure 2-1. MS-320X Mounting Dimensions

## Mounting the Scanner on the Stand (optional)

To mount the scanner on the optional stand:

1. Place the bottom of the scanner on the stand's scanner mount, aligning the scanner's center threaded insert (beneath the scan window) with the center mounting hole on the front of the stand. The two rear threaded inserts on the bottom of the scanner will align with the proper mounting holes on the stand.
2. Secure the scanner to the stand using the three screws provided with the stand.

## Assembling the Stand

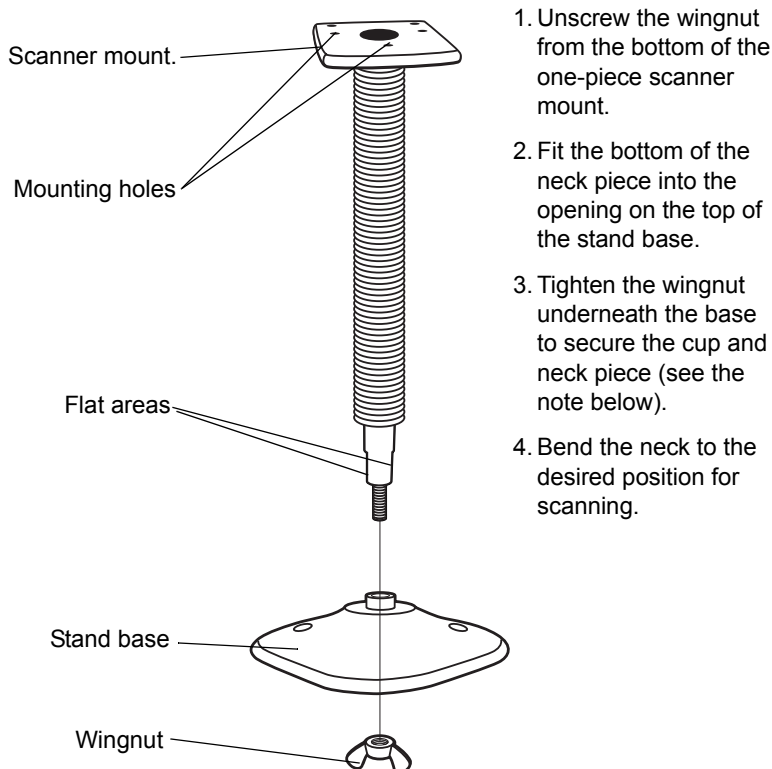
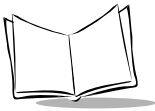


Figure 2-2. Assembling the Stand



---

**Note:** Before tightening the wingnut under the base, ensure that the flat areas on the flexible neck fit securely in the grooves in the base.

---

## Mounting the Stand (optional)

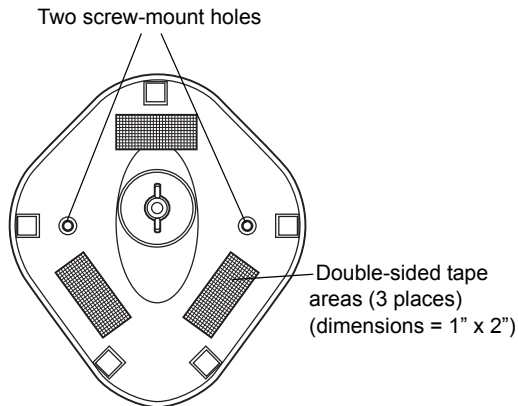
You can attach the base of the scanner's stand to a flat surface using two screws or double-sided tape (not provided).

### Screw Mount

1. Position the assembled base on a flat surface.
2. Screw one #10 wood screw into each screw-mount hole until the base of the stand is secure.

### Tape Mount

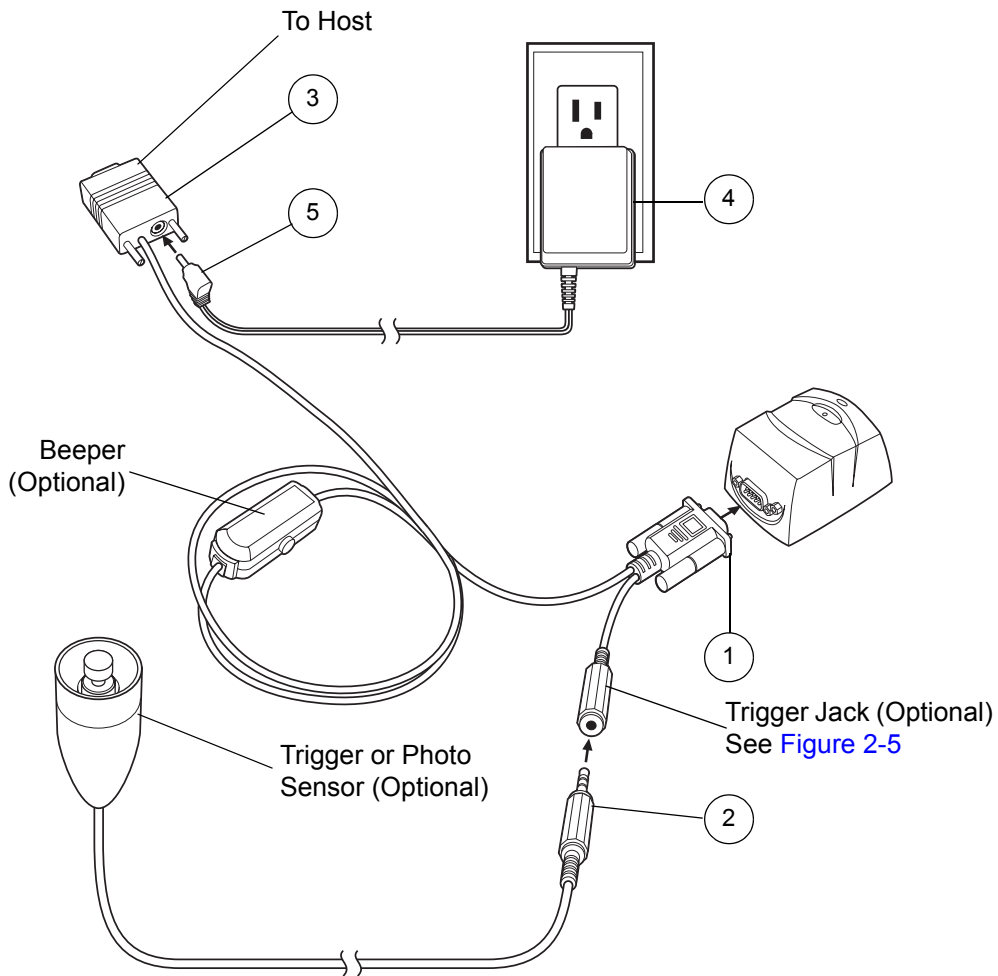
1. Peel the paper liner off one side of each piece of tape and place the sticky surface over each of the three rectangular tape areas.
2. Peel the paper liner off the exposed sides of each piece of tape and press the stand on a flat surface until it is secure.



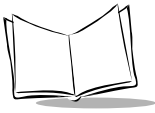
**Figure 2-3. Mounting the Stand**

## Connecting MiniScan

To connect the MiniScan to the host, connect the scanner cables in the order shown below.



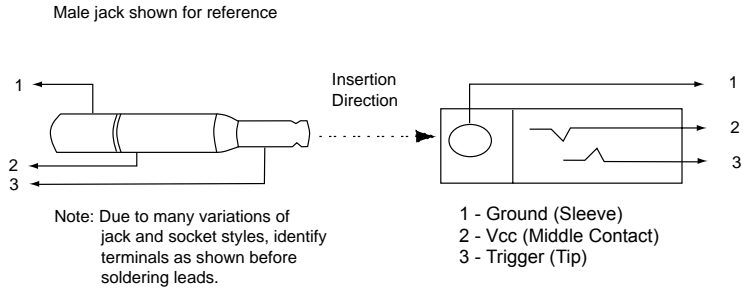
**Figure 2-4. Typical Connection Diagram**



---

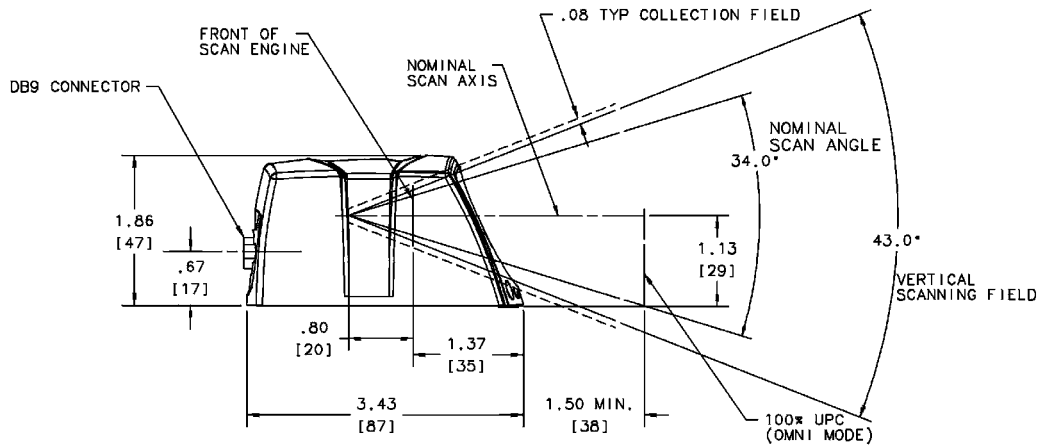
**Note:** The power supply is not required for USB connection, as the MS-3207 draws power from the USB port.

---



**Figure 2-5. Trigger Jack Connector Pins**

# Mechanical Drawing



Notes:

Unless otherwise specified:

- Dimensions are in inches, dimensions in [ ] are mm.
- User mounting tolerances are not included.

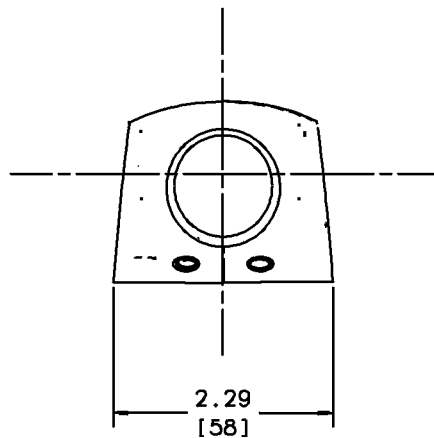
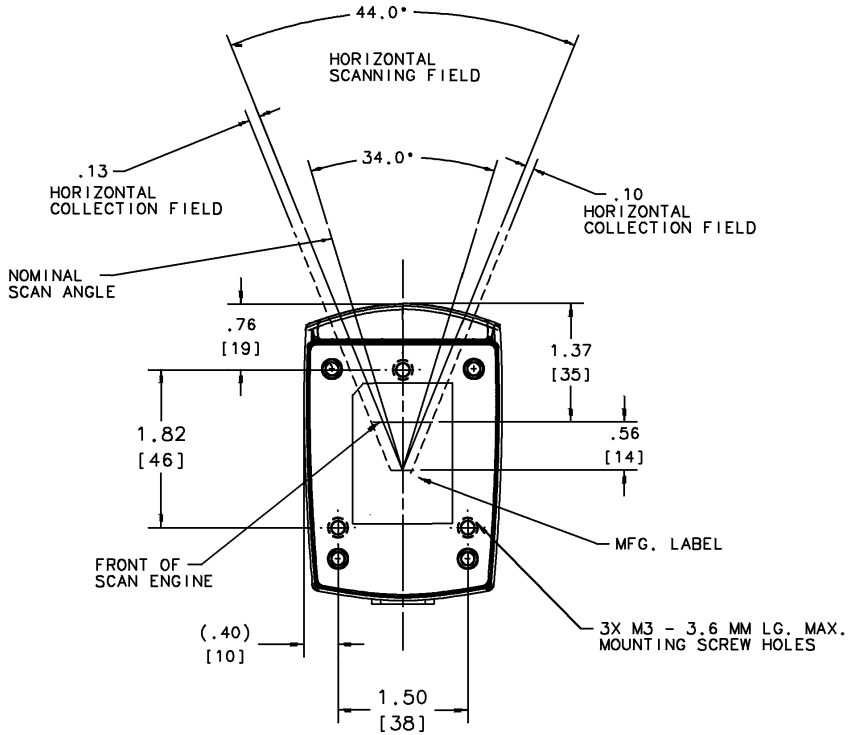
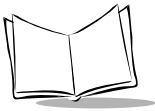


Figure 2-6. MS-320X Mechanical Drawing





Notes:

Unless otherwise specified:

- Dimensions are in inches, dimensions in [ ] are mm.
- User mounting tolerances are not included.

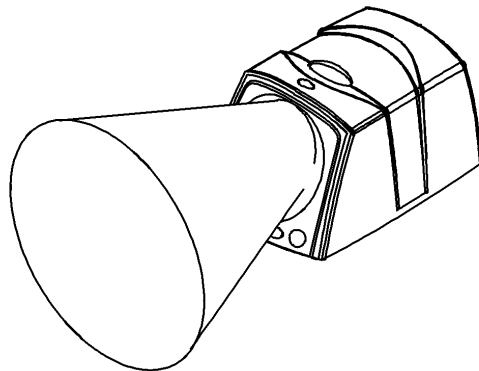


Figure 2-7. MS-320X Mechanical Drawing

## Location and Positioning

---

### **Caution**

The location and positioning guidelines provided do not consider unique application characteristics. It is recommended that an opto-mechanical engineer perform an opto-mechanical analysis prior to integration.

---

**Note:** *Integrate the scanner in an environment no more extreme than the product's specification, where the scanner will not exceed its temperature range. For instance, do not mount the scanner on to or next to a large heat source. When placing the scanner with another device, ensure there is proper convection or venting for heat. Follow these suggestions to ensure product longevity, warranty, and overall satisfaction with the scanner.*

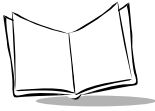
---

### **Using the MiniScan as an Embedded Scanner**

The MiniScan can be mounted to read symbols that are automatically presented, or that are presented in a pre-determined location. In these applications, MiniScan positioning with respect to the symbol is critical. Failure to properly position the MiniScan can result in unsatisfactory scanning performance. A thermal analysis is also recommended.

Two methods of positioning the scanner are provided:

- The [Calculating The Usable Scan Length Method](#) on page 2-10 can be used with consistently good quality symbols. It provides a mathematical solution to find the usable scan length.
- The [Testing The Usable Scan Length Method](#) on page 2-11 uses real situation testing to adjust the usable scan length to fit the application conditions.



## Calculating The Usable Scan Length Method

Calculate usable scan length as follows (see [Figure 2-8 on page 2-11](#)):

$$L = 2 \times (D+d+B) \times \tan (A/2)$$

**Table 2-1. Calculation Constants**

Constants	B	A
MS-320x	1.93	34°

Where:

D = Distance (in inches) from the front edge of the host housing to the bar code.

d = The host housing's internal optical path from the edge of the housing to the front of the MiniScan scanner.

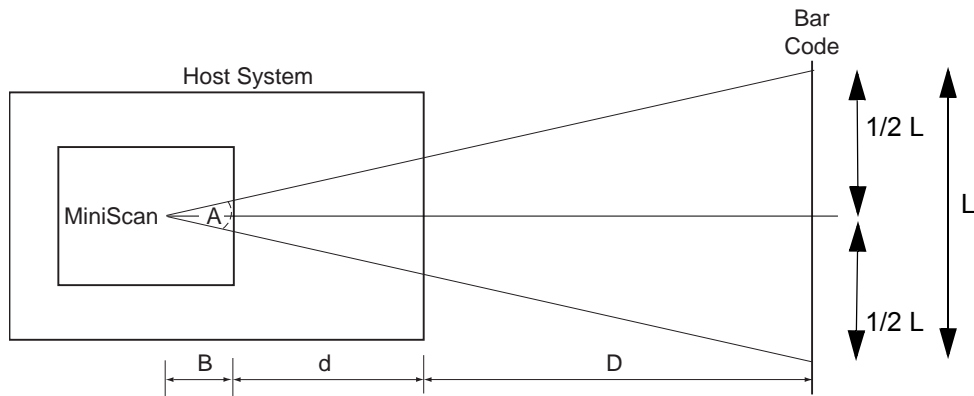
B = Internal optical path from the scan mirror to the front edge of the MiniScan scanner.

A = Scan angle in degrees.

---

**Note:** Usable scan length determined by this formula, or 90% of scan line at any working distance. This formula is based on good quality symbols in the center of the working range and length of bar code.

---



**Figure 2-8. Usable Scan Length Diagram**

## Testing The Usable Scan Length Method

Due to the variety of symbol sizes, densities, print quality, etc., there is no simple way to calculate the ideal symbol distance. To optimize performance, use the *Testing The Usable Scan Length* positioning method:

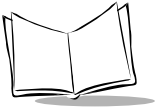
1. Measure the maximum and minimum distances at which the symbols can be read.
2. Check the near and far range on several symbols. If they are not reasonably consistent there may be a printing quality problem that can degrade the performance of the system. Symbol Technologies can provide advice on how to improve the installation.

---

**Note:** *Poor quality symbols (from bad printing, wear, or damage) may not decode well when placed in the center of the depth of field (especially higher density codes). The scan beam has a minimum width in the central area, and when the scanner tries to read all symbol imperfections in this area it may not decode. After a preliminary spot is determined using good quality symbols, test several reduced quality symbols and adjust the spot for the best overall symbol position.*

---

3. Locate the scanner so the symbol is near the middle of the near/far range.
4. Center the symbol (left to right) in the scan line whenever possible.



5. Position the symbol so that the scan line is as near as possible to perpendicular to the bars and spaces in the symbol.
6. Avoid specular reflection (glare) off the symbol by tilting the top or bottom of the symbol away from the scanner. The exact angle is not critical, but it must be large enough so that if a mirror were inserted in the symbol location, the reflected scan line would miss the front surface of the scanner. For the maximum allowable angles refer to the Skew, Pitch and Roll angles listed in each MiniScan *Technical Specifications* Table.
7. If an additional window is to be placed between the scanner and the symbol, determine the optimum symbol location using a representative window in the desired window position. Review the sections of this chapter concerning window quality, coatings and positioning.
8. Give the scanner time to dwell on the symbol for several scans. When first enabled, the MiniScan may take two or three scans before it reaches maximum performance. Enable the MiniScan before the symbol is presented, if possible.

## **Conveyor Applications**

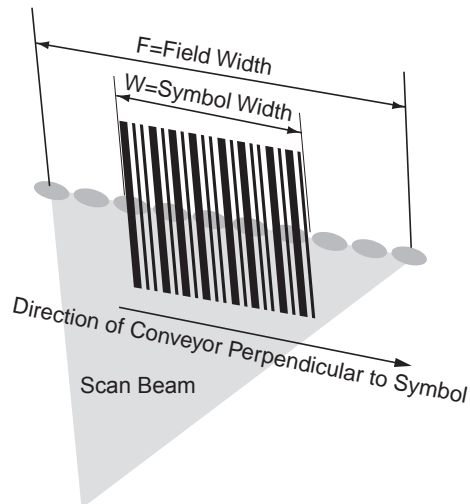
Conveyor applications require setting the conveyor velocity to optimize the scanner's ability to read symbols. Also consider the orientation of the symbol with respect to the conveyor direction. [Figure 2-9 on page 2-13](#) illustrates the relationship of the conveyor velocity with respect to a symbol positioned perpendicular to the conveyor direction and [Figure 2-10 on page 2-14](#) illustrates the relationship of the conveyor velocity with respect to a symbol positioned parallel to the conveyor direction.

### Symbol is Perpendicular to Conveyor Movement

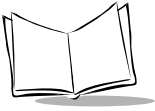
With the symbol bars perpendicular to the conveyor belt direction (Picket Fence presentation) the relationship is:

$$V = (R \times (F - W)) / N$$

- where:
- V = Velocity of the conveyor (inches/second)
  - R = Scan Rate (640 scans/second)
  - F = Field width of scan beam
  - W = Symbol Width (inches)
  - N = Number of scans over symbol (minimum of 10 scans)



**Figure 2-9. Symbol Perpendicular To Conveyor Movement**



## Symbol is Parallel to Conveyor Movement

With the symbol bars parallel to the conveyor belt direction (Ladder presentation) the relationship is:

$$V = (R \times H) / N$$

where:

V = Velocity of the conveyor (inches/second)

R = Scan Rate (640 scans/second)

H = Symbol height

N = Number of scans over symbol (minimum of 10 scans)

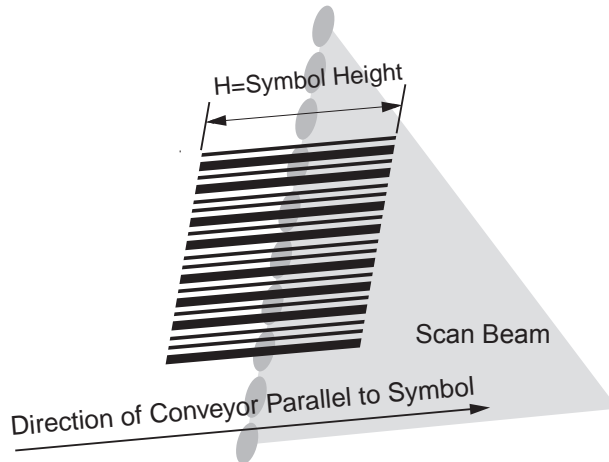


Figure 2-10. Symbol Parallel To Conveyor Movement

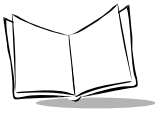
## Accessories

---

The following accessories are available for the MiniScan scanner, and can be found in Symbol's Solution Builder (ordering guide).

- **For power connection**
  - 110V power supply, US, p/n 50-14000-008
  - 220V power supply, Europe, p/n 50-14000-009
  - 100V power supply, Asia, p/n 50-14000-010
  - 264V Universal power supply (also order cables below), p/n 50-14001-001
    - DC line cord (power supply to scanner), p/n 50-16002-009
    - AC line cord (wall outlet to power supply), p/n 23844-00-00
- **RS-232**
  - Female DB9 with straight connector to RS-232 host (female DB9), with trigger jack and no beeper, p/n 25-13227-XX
  - Female DB9 with straight connector to RS-232 host (female DB9), with trigger jack and beeper, p/n 25-13228-XX
  - Female DB9 with straight connector to RS-232 host (female DB9), p/n 25-58918-XX
  - Female DB9 with right angle connector to RS-232 host (female DB9), p/n 25-58919-XX
  - Female DB9 with straight connector to RS-232 host (female DB9), with trigger jack and no hardware handshaking, p/n 25-63736-XX
  - TTL RS-232 to True RS-232 conversion cable, p/n 25-62186-XX (MS-3207 only)
- **USB**
  - Female DB9 with straight connector with trigger jack and beeper to USB (Type A connector), p/n 25-58925-XX
  - Female DB9 with right angle connector to USB host (Type A connector), p/n 25-58923-XX
  - Female DB9 straight to USB, p/n 25-58926-XX
- **Synapse Adapter**
  - Female DB9 with straight connector to Synapse Adapter Cable (6 ft. straight), p/n 25-58921-XX





- **Cable Adapters**
  - Female 25 pin D, TxD on pin 2, p/n 50-12100-378
  - Female 25 pin D, TxD on pin 3, p/n 50-12100-377
  - Male 25 pin D, TxD on pin 2, p/n 50-12100-380
  - Male 25 pin D, TxD on pin 3, p/n 50-12100-379
- **Optional Accessories**
  - Push button trigger cable, p/n 25-04950-XX
  - Photo sensor trigger cable, p/n 25-13176-XX
  - Fixed mount stand, p/n 20-60136-XX
- **other**
  - Software Developer's CD, p/n SW-60371-XX
  - 123Scan CD, SW-56638-XX.

## **Software Development CD**

The Software Development CD provides the software tools required to integrate and communicate with the MS-3204, including:

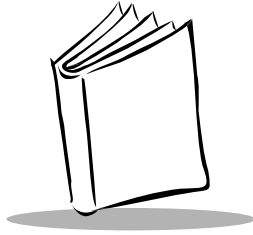
- Sample Windows<sup>®</sup> program with source code
- DLL with source code for building user applications
- ActiveX component (including help file) for easy integration into VisualBasic programs
- Simple Serial Interface documentation.

With over 70 programmable parameters, the MS-3204 can be configured by scanning bar code menus, or through the serial interface using Symbol's Simple Serial Interface protocol.

For Windows<sup>®</sup>, DOS, and embedded system environments, the CD enables the user to take full advantage of the scanner's features and obtain maximum performance.

## **123Scan CD**

123Scan is a Windows<sup>®</sup>-based utility that enables programming the MS-3207 with all parameters, including Advanced Data Formatting (ADF) rules. An ADF rule modifies bar code data before it is sent to the host to ensure compatibility between this data and the host application, so there is no need to modify the host software. Scanners can be programmed via PC download or by scanning a sheet of bar codes generated by the 123Scan utility. This programming information is saved in a file that can be distributed electronically. The 123Scan program includes a help file.



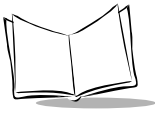
## *Chapter 3*

# *MS-3204 Specifications*

### **Overview**

---

This chapter provides the technical specifications for MS-3204 scanners.



## Electrical Interface

This section describes the pin functions of the MS-3204 scanner.

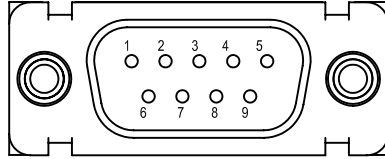


Figure 3-1. MS-3204 Connector

Table 3-1. MS-3204 Electrical Interface

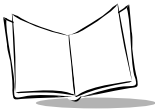
Pin No.	Pin Name	Type*	Function
1	Trigger	I	Signals scanner to begin scanning session.
2	TXD	O	Serial data transmit output. Drives the serial data receive input on the device communicating with the scanner.
3	RXD	I	Serial data receive input. Driven by the serial data transmit output on the device communicating with the scanner.
4	Not used		
5	Ground		Power supply ground input and signal ground reference.
6	Power	I	5.0 VDC $\pm$ 10%
7	CTS	I	Clear-to-send handshaking input line, used only in conjunction with the RTS line. Optionally used by another device to signal the scanner to begin transmitting data.
8	RTS	O	Request-to-send handshaking output line, used only in conjunction with the CTS line. Optionally used by the scanner to signal another device that data is available to send.
9	Beeper/ Download	I/O	During normal operation this signal functions as an external beeper drive line. This signal can sink 50mA of current to drive an external beeper, and is normally pulled up. This signal is also used to begin Flash Download operation when grounded externally during power up.

\*I = Input    O = Output

## MS-3204 Technical Specifications

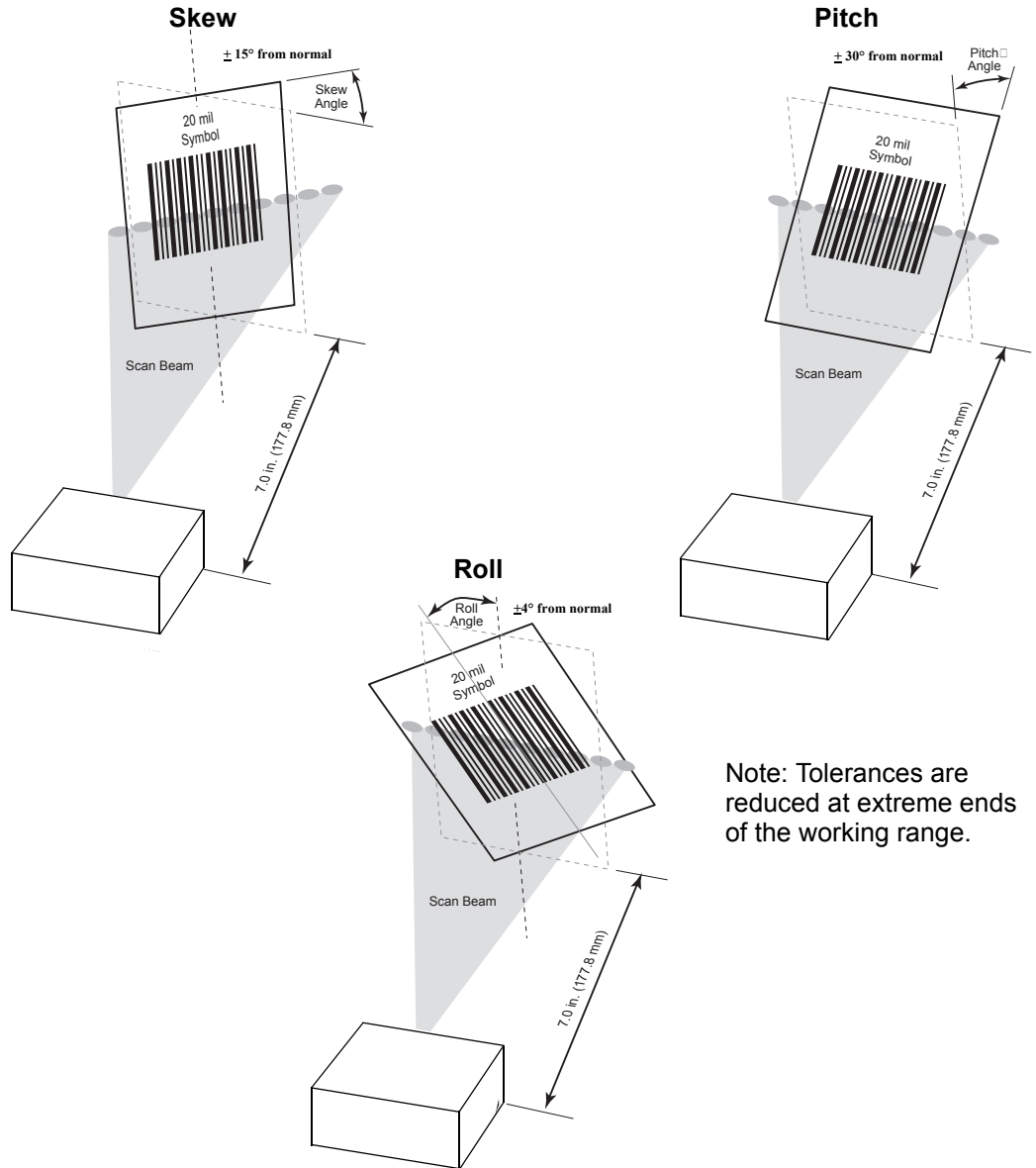
Table 3-2. MS 3204 Technical Specifications @ 23°C

Item	Description
<b>Power Requirements</b>	
<b>Input Voltage</b>	+5.0 VDC $\pm$ 10%
<b>Scanning Current</b>	250 $\pm$ 30 mA typical
<b>Standby Current</b>	25 $\pm$ 5 mA typical
<b>V<sub>CC</sub> Noise Level</b>	200 mV peak-to-peak max.
<b>Laser Power</b>	0.7 mW typical, 0.8 mW maximum, $\lambda$ = 650 nm
<b>Scan Pattern</b>	<b>MS-3204-I000:</b> Omnidirectional, semi-omnidirectional, smart raster, slab raster pattern <b>MS-3204-E000:</b> Omnidirectional only
<b>Scan Rate</b>	640 scans/second
<b>Start Time</b>	0.065 sec. to 75% of steady state horizontal amplitude
<b>Scan Angle</b>	Horizontal: 34° $\pm$ 1.5° Vertical: 34° $\pm$ 1.5°
<b>Beam Deviation (offset from the nominal)</b>	Horizontal: $\pm$ 3.0° Vertical: $\pm$ 3.0° Horizontal tilt: $\pm$ 2°
<b>Additional Post Shock Beam Deviation (2000G Shock)</b>	Horizontal: $\pm$ 3.0° max Vertical: $\pm$ 6.0° max
<b>Scan Frequency: Horizontal</b>	320 Hz $\pm$ 5 Hz
<b>Scan Frequency: Vertical</b>	282 Hz $\pm$ 5 Hz
<b>Frame Rate</b>	24 frames/sec. 12 Hz $\pm$ 1 Hz (vertical)
<b>Pitch Angle</b>	$\pm$ 30° from normal (see <a href="#">Figure 3-2 on page 3-5</a> )
<b>Skew Tolerance</b>	$\pm$ 15° from normal (see <a href="#">Figure 3-2 on page 3-5</a> )
<b>Roll</b>	$\pm$ 4° from vertical (see <a href="#">Figure 3-2 on page 3-5</a> ) (For scanning benchmark label, assuming 3:1 codeword aspect ratio). Note that this is dependent on the decoder.
<b>Print Contrast Minimum</b>	35% absolute dark/light reflectance differential (PDF); 35% absolute dark/light reflectance differential (1D)



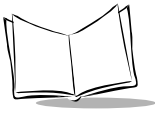
**Table 3-2. MS 3204 Technical Specifications @ 23°C (Continued)**

<b>Item</b>	<b>Description</b>
<b>Humidity</b>	5% to 95% non-condensing
<b>Drop</b>	30 inch drop
<b>Vibration</b>	Unpowered scanner withstands a random vibration along each of the X, Y and Z axes for a period of one hour per axis, defined as follows: 20 to 80 Hz Ramp up to 0.04 G <sup>2</sup> /Hz at the rate of 3dB/octave. 80 to 350 Hz 0.04 G <sup>2</sup> /Hz 350 to 2000 Hz Ramp down at the rate of 3 dB/octave.
<b>ESD</b>	± 20kV air discharge ± 8kV indirect discharge
<b>Laser Class</b>	CDRH Class II, IEC Class 2
<b>Ambient Light Immunity</b> <b>Sunlight</b> <b>Artificial Light</b>	8,000 ft. candles (86,112 lux) 450 ft. candles (4,844 lux)
<b>Operational Temperature</b>	-86 °F to 122 °F (-30 °C to 50 °C)
<b>Storage Temperature</b>	-104 °F to 158 °F (-40 °C to 70 °C)
<b>Height</b>	1.89 in. (4.80 cm)
<b>Width</b>	2.31 in. (5.87 cm)
<b>Depth</b>	3.50 in. (8.89 cm)
<b>Weight</b>	4.8 oz. (137 g)



Note: Tolerances are reduced at extreme ends of the working range.

Figure 3-2. Skew, Pitch and Roll

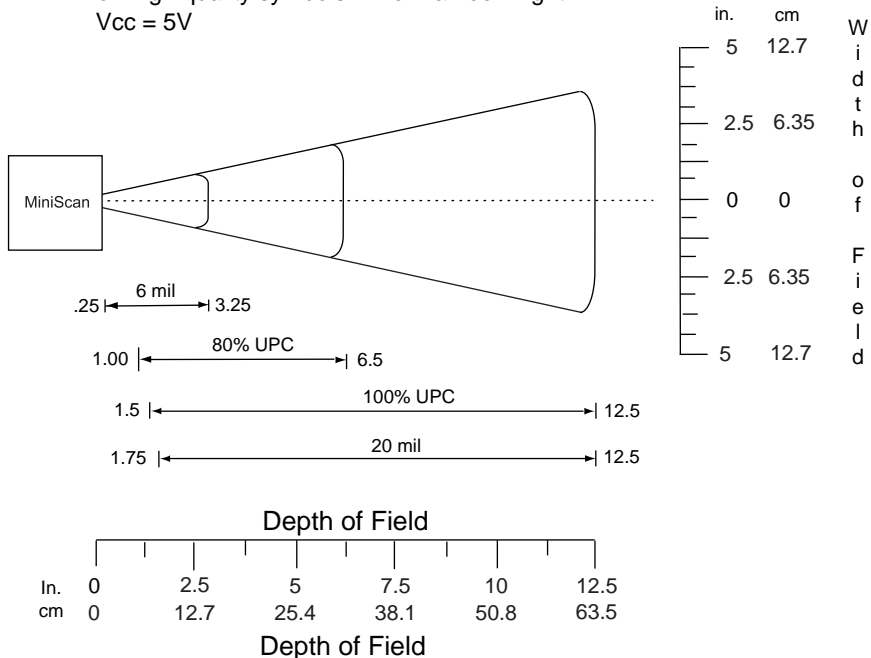


# MS-3204 Decode Zones

The decode zone is a function of various symbol characteristics including density, print contrast, wide to narrow ratio and edge acuity. The figures shown are typical values. [Table 3-3 on page 3-7](#) and [Table 3-4 on page 3-9](#) list the typical and guaranteed distances for selected bar code densities. The minimum element width (or “symbol density”) is the width in mils of the narrowest element (bar or space) in the symbol. The maximum usable length of a symbol at any given range is shown below. To calculate this distance, see [Calculating The Usable Scan Length Method](#) on page 2-10.

## Omnidirectional Decode Distances

Note: Typical performance at 68°F (20°C)  
on high quality symbols in normal room light.  
Vcc = 5V



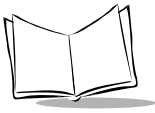
\* Minimum distance determined by symbol length and scan angle.

**Figure 3-3. MS-3204 Omnidirectional Decode Zone**

Table 3-3. MS-3204 Omnidirectional Decode Distances

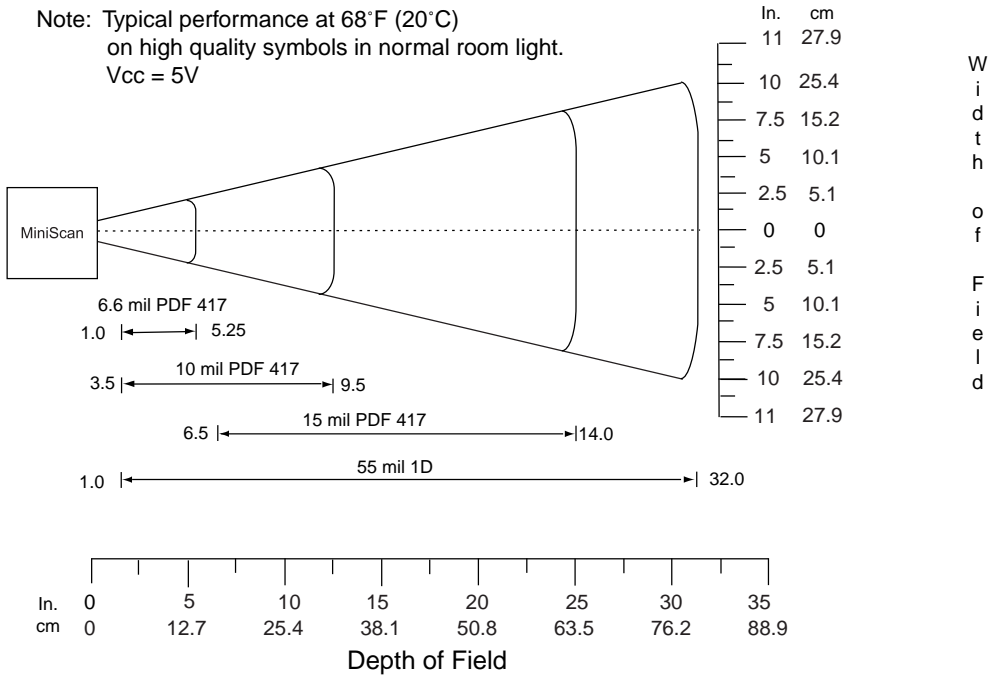
Symbol Density/ Symbol p/n / Bar Code Type	Bar Code Content/ Contrast <sup>1</sup>	Typical Working Ranges <sup>3</sup>		Guaranteed Working Ranges <sup>3</sup>	
		Near	Far	Near	Far
6.0 mil 60-01755-01 Code 39	123 80% MRD	<b>0.25 in.</b> 0.64 cm	<b>3.25 in.</b> 8.3 cm	<b>0.75 in.</b> 1.9 cm	<b>2.25 in.</b> 5.7 cm
64-06629-01 80% UPC	0080015 80% MRD	<b>1.0 in.</b> 2.5 cm	<b>6.5 in.</b> 16.5 cm	<b>1.5 in.</b> 3.8 cm	<b>4.5 in.</b> 11.4 cm
13 mil 64-05303-01 100% UPC	012345678905 80% MRD	<b>1.5 in.</b> 3.8 cm	<b>12.5 in.</b> 31.2 cm	Note 2	<b>9.5 in.</b> 24.1 cm
20 mil 1D 60-02710-03 LC 35%	123 80% MRD	<b>1.75 in.</b> 4.4 cm	<b>12.5 in.</b> 31.8 cm	Note 2	<b>10.0 in.</b> 25.4 cm
Notes: 1. CONTRAST measured as Mean Reflective Difference (MRD) at 650 nm. 2. Near ranges on largely depend on the width of the bar code and the scan angle. 3. Working range specifications: Photographic quality symbols, pitch = 15°, skew = 0°, roll = 0°, ambient light < 150 ft. candles, and temperature = 23 °C, Vcc = 5V. 4. Measured from the front of the scanner.					





## 2D Slab/Raster Decode Distances (MS-3204-I000 Only)

Note: Typical performance at 68°F (20°C)  
on high quality symbols in normal room light.  
Vcc = 5V



\* Minimum distance determined by symbol length and scan angle.

**Figure 3-4. MS-3204 2D Slab/Raster Decode Distance**

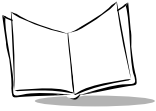
Table 3-4. MS-3204-I000 2D Slab/Raster Decode Distances

Symbol Density/ Symbol p/n / Bar Code Type	Bar Code Content/ Contrast <sup>1</sup>	Typical Working Ranges <sup>3</sup>		Guaranteed Working Ranges <sup>3</sup>	
		Near	Far	Near	Far
6.6 mil 64-14035-01 2D	123 80% MRD	<b>1.0 in.</b> 2.54 cm	<b>5.25 in.</b> 13.34 cm	<b>1.5 in.</b> 3.8 cm	<b>3.75 in.</b> 9.5 cm
10 mil 64-14037-01 2D	ABCDEF 80% MRD	<b>3.5 in.</b> 8.89 cm	<b>9.5 in.</b> 24.13 cm	<b>5.0 in.</b> 12.7 cm	<b>7.5 in.</b> 9.5 cm
15 mil 64-14038-01 2D	012345678905 80% MRD	<b>6.5 in.</b> 16.51 cm	<b>14.0 in.</b> 35.6 cm	Note 2	<b>11.0 in.</b> 24.1 cm
55 mil 64-17458-01 1D	CD 80% MRD	<b>1.0 in.</b> 2.54 cm	<b>32 in.</b> 81.3 cm	Note 2	<b>22.0 in.</b> 55.9 cm
Notes: 1. CONTRAST measured as Mean Reflective Difference (MRD) at 650 nm. 2. Near ranges on largely depend on the width of the bar code and the scan angle. 3. Working range specifications: Photographic quality symbols, pitch = 15°, skew = 0°, roll = 0°, ambient light < 150 ft. candles, and temperature = 23 °C, Vcc = 5V. 4. Measured from the front of the scanner.					

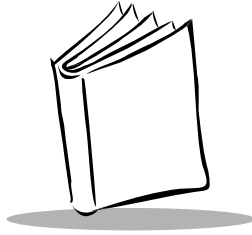
## Usable Scan Length

The decode zone is a function of various symbol characteristics including density, print contrast, wide-to-narrow ratio, and edge acuity. Consider width of decode zone at any given distance when designing a system.

[Calculating The Usable Scan Length Method](#) on page 2-10 describes how to calculate the usable scan length. The scan angle is provided in [Table 3-2 on page 3-3](#).



*MiniScan MS-320X Integration Guide*



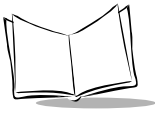
## *Chapter 4*

# *MS-3207 Specifications*

### **Overview**

---

This chapter provides the technical specifications for the MS-3207.



## Electrical Interface

This section describes the pin functions of the MS-3207 interface.

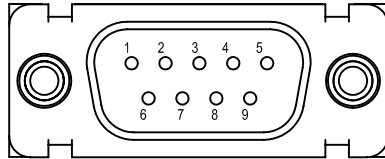


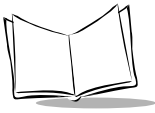
Figure 4-1. MS-3207 Connector

Table 4-1. MS-3207 Electrical Interface

Pin No.	Pin Name	Type*	Function
1	Trigger	I	Signals to scanner to begin scanning session.
2	TXD	O	Serial data transmit output. Drives the serial data receive input on the device communicating with the scanner.
3	RXD/D+	I/O	RS-232 Mode: Serial data receive input. Driven by the serial data transmit output on the device communicating with the scanner.  USB Mode: D+ signal. During USB operation this signal is pulled up by a 1.5k Ohm resistor to begin USB enumeration. In this mode it is a differential bi-directional signal.
4	SYN_CLK	I/O	Synapse Mode: Synapse Clock line. Signal used as a clock by a Symbol Synapse host. Pin is shorted to RTS/SYN_DAT in USB cables to allow for auto-detection of USB mode via signal loopback.
5	Ground		Power supply ground input and signal ground reference.
6	Power		5.0 VDC $\pm$ 10%

**Table 4-1. MS-3207 Electrical Interface (Continued)**

Pin No.	Pin Name	Type*	Function
7	CTS/D-	I/O	<p>RS-232 Mode: Clear-to-send handshaking input line, used only in conjunction with the RTS line. Optionally used by another device to signal the scanner to begin transmitting data.</p> <p>USB Mode: D- signal. During USB operation this signal works in conjunction with the D+ signal as a differential bi-directional signal.</p>
8	RTS/SYN_DAT	I/O	<p>RS-232 Mode: Request-to-send handshaking output line, used only in conjunction with the CTS line. Optionally used by the scanner to signal another device that data is available to send.</p> <p>Synapse Mode: Synapse Data line. Signal is used to transmit data to and from a Symbol Synapse host.</p>
9	Beeper/ Download	I/O	<p>During normal operation this signal functions as an external beeper drive line. This signal can sink 50mA of current to drive an external beeper, and is normally pulled up. This signal is also used to begin Flash Download operation when grounded externally during power up.</p>
*I = Input    O = Output			



## MS-3207 Technical Specifications

Table 4-2. MS-3207 Technical Specifications @ 23°C

Item	Description
<b>Power Requirements</b>	
<b>Input Voltage</b>	+5.0 VDC $\pm$ 10%
<b>Scanning Current</b>	250 $\pm$ 30 mA typical
<b>Standby Current</b>	45 $\pm$ 10 mA typical
<b>V<sub>CC</sub> Noise Level</b>	200 mV peak-to-peak max.
<b>Laser Power</b>	0.7 mW typical, 0.8 mW maximum @ 650 nm
<b>Scan Pattern</b>	Omnidirectional, semi-omnidirectional, smart raster, slab raster pattern
<b>Scan Rate</b>	640 scans/second
<b>Start Time</b>	0.065 sec. to 75% of steady state horizontal amplitude
<b>Scan Angle</b>	Horizontal: 34° $\pm$ 1.5° Vertical: 34° $\pm$ 1.5°
<b>Beam Deviation (offset from the nominal)</b>	Horizontal: $\pm$ 3.0° Vertical: $\pm$ 3.0° Horizontal tilt: $\pm$ 2°
<b>Additional Post Shock Beam Deviation (2000G Shock)</b>	Horizontal: $\pm$ 3.0° max Vertical: $\pm$ 6.0° max
<b>Scan Frequency: Horizontal</b>	320 Hz $\pm$ 5 Hz
<b>Scan Frequency: Vertical</b>	282 Hz $\pm$ 5 Hz
<b>Frame Rate</b>	24 frames/sec. 12 Hz $\pm$ 1 Hz (vertical)
<b>Pitch Angle</b>	$\pm$ 30° from normal (see <a href="#">Figure 4-2 on page 4-6</a> )
<b>Skew Tolerance</b>	$\pm$ 15° from normal (see <a href="#">Figure 4-2 on page 4-6</a> )
<b>Roll</b>	$\pm$ 4° from vertical (see <a href="#">Figure 4-2 on page 4-6</a> ) (For scanning benchmark label, assuming 3:1 codeword aspect ratio). Note that this is dependent on the decoder.
<b>Print Contrast Minimum</b>	35% absolute dark/light reflectance differential (PDF); 35% absolute dark/light reflectance differential (1-D)
<b>Humidity</b>	5% to 95% non-condensing
<b>Drop</b>	30 inch drop

Table 4-2. MS-3207 Technical Specifications @ 23°C (Continued)

Item	Description
<b>Vibration</b>	Unpowered scanner withstands a random vibration along each of the X, Y and Z axes for a period of one hour per axis, defined as follows: 20 to 80 Hz      Ramp up to 0.04 G <sup>2</sup> /Hz at the rate of 3dB/octave. 80 to 350 Hz      0.04 G <sup>2</sup> /Hz 350 to 2000 Hz      Ramp down at the rate of 3 dB/octave.
<b>ESD</b>	± 20kV air discharge ± 8kV indirect discharge
<b>Laser Class</b>	CDRH Class II, IEC Class 2
<b>Ambient Light Immunity</b> <b>Sunlight</b> <b>Artificial Light</b>	8,000 ft. candles (86,112 lux) 450 ft. candles (4,844 lux)
<b>Operational Temperature</b>	-86 °F to 122 °F (-30 °C to 50 °C)
<b>Storage Temperature</b>	-104 °F to 158 °F (-40 °C to 70 °C)
<b>Height</b>	1.89 in. (4.80 cm)
<b>Width</b>	2.31 in. (5.87 cm)
<b>Depth</b>	3.50 in. (8.89 cm)
<b>Weight</b>	4.97 oz. (142 g)



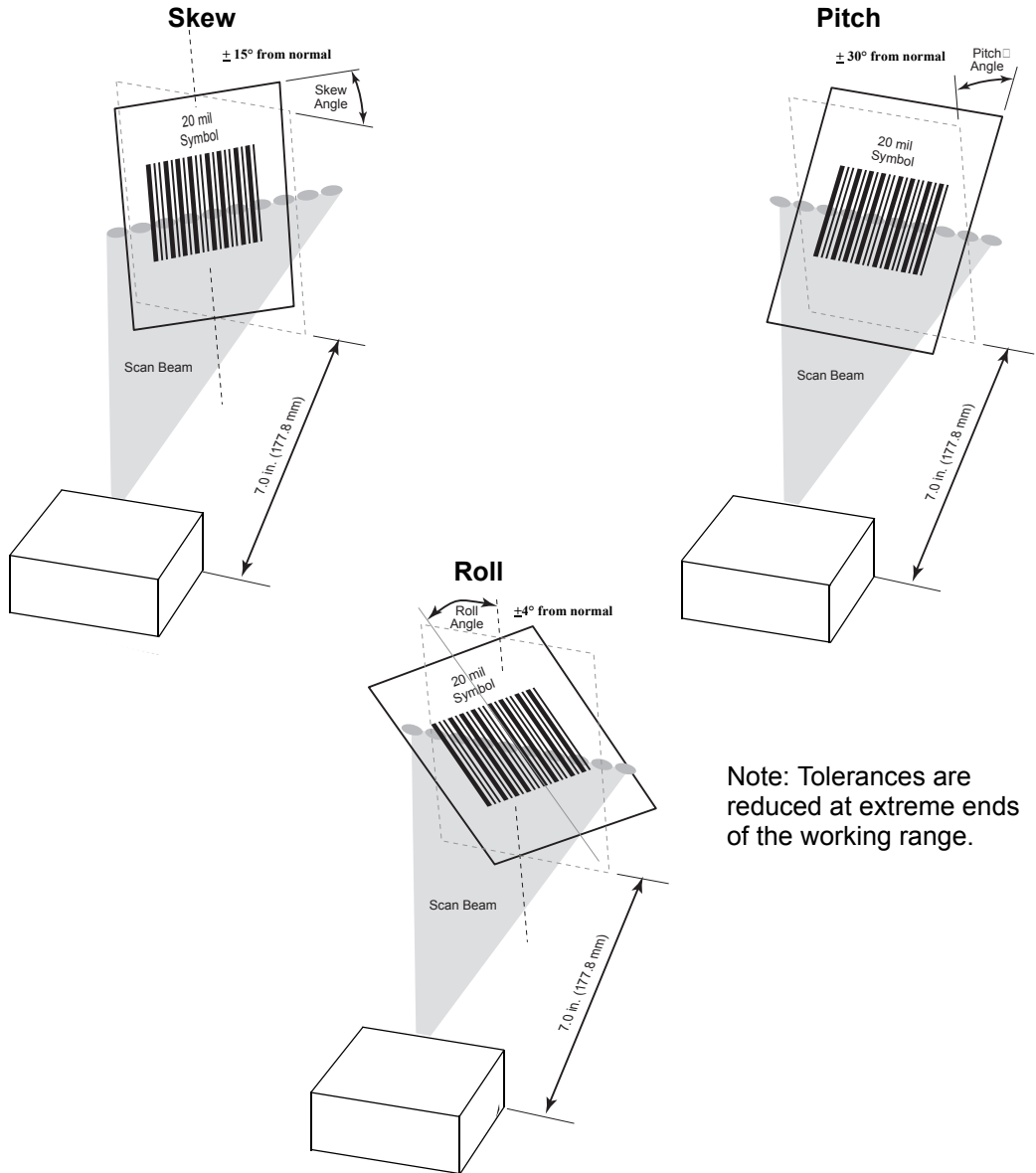
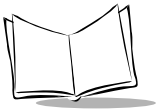


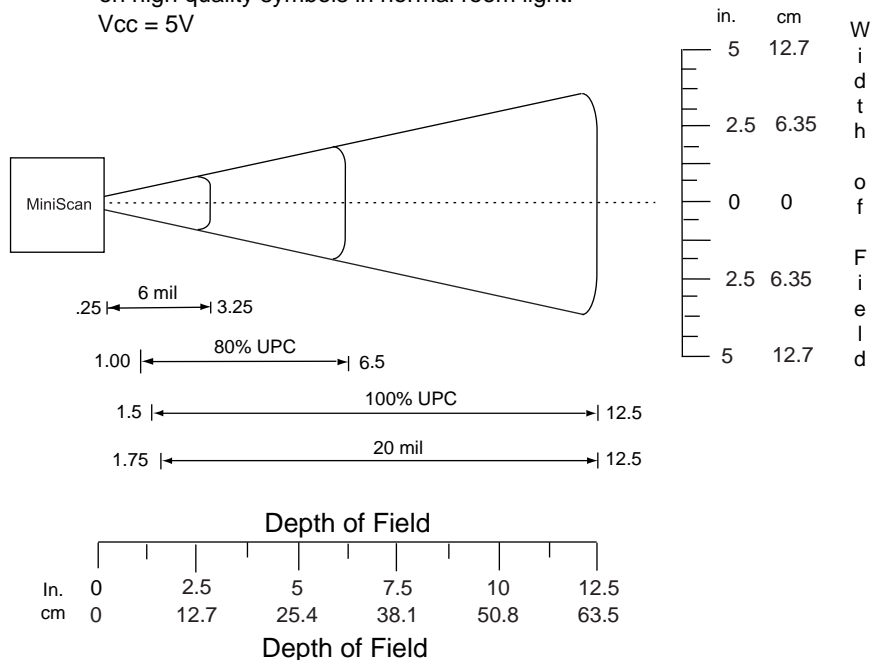
Figure 4-2. Skew, Pitch and Roll

# MS-3207 Decode Zones

The decode zone is a function of various symbol characteristics including density, print contrast, wide to narrow ratio and edge acuity. The figures shown are typical values. [Table 4-3 on page 4-8](#) and [Table 4-4 on page 4-10](#) list the typical and guaranteed distances for selected bar code densities. The minimum element width (or “symbol density”) is the width in mils of the narrowest element (bar or space) in the symbol. The maximum usable length of a symbol at any given range is shown below. To calculate this distance, see [Calculating The Usable Scan Length Method](#) on page 2-10.

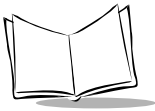
## Omnidirectional Decode Distances

Note: Typical performance at 68°F (20°C)  
on high quality symbols in normal room light.  
Vcc = 5V



\* Minimum distance determined by symbol length and scan angle.

**Figure 4-3. MS-3207 Omnidirectional Decode Zone (Typical)**



**Table 4-3. MS-3207 Omnidirectional Decode Distances**

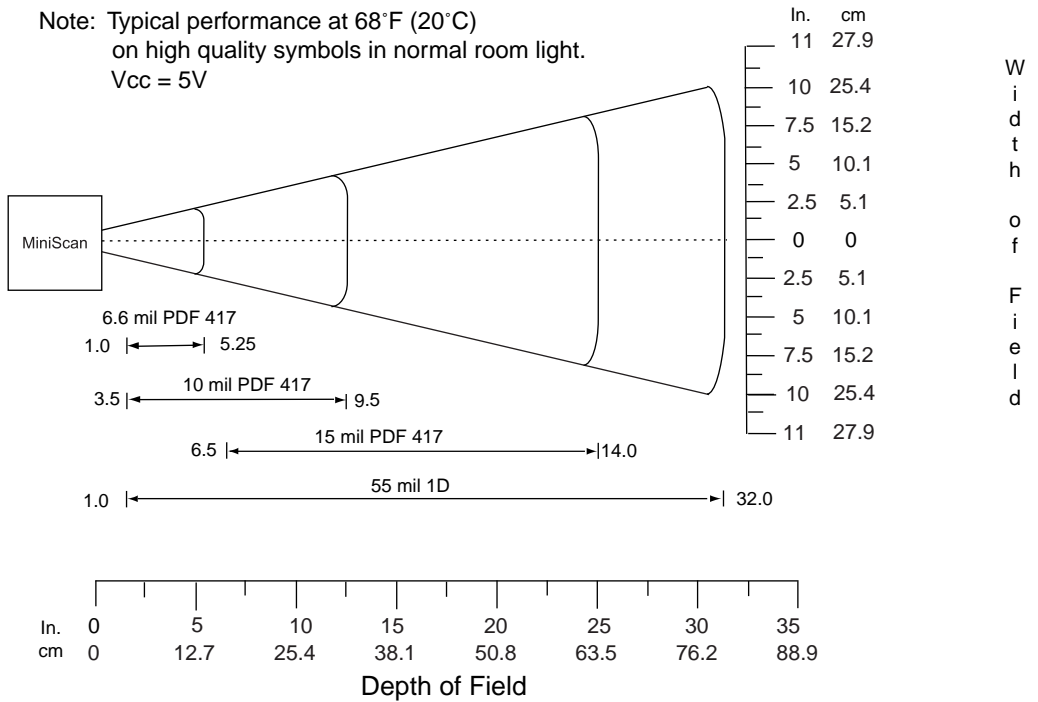
Symbol Density/ Symbol p/n / Bar Code Type	Bar Code Content/ Contrast <sup>1</sup>	Typical Working Ranges <sup>3</sup>		Guaranteed Working Ranges <sup>3</sup>	
		Near	Far	Near	Far
6.0 mil 60-01755-01 Code 39	123 80% MRD	<b>0.25 in.</b> 0.64 cm	<b>3.25 in.</b> 8.3 cm	<b>0.75 in.</b> 1.9 cm	<b>2.25 in.</b> 5.7 cm
64-06629-01 80% UPC	0080015 85% MRD	<b>1.0 in.</b> 2.5 cm	<b>6.5 in.</b> 16.5 cm	<b>1.5 in.</b> 3.8 cm	<b>4.5 in.</b> 11.4 cm
13 mil 64-05303-01 100% UPC	012345678905 80% MRD	<b>1.5 in.</b> 3.8 cm	<b>12.5 in.</b> 31.2 cm	Note 2	<b>9.5 in.</b> 24.1 cm
20 mil 1D 60-02710-03 LC 35%	123 80% MRD	<b>1.75 in.</b> 4.4 cm	<b>12.5 in.</b> 31.8 cm	Note 2	<b>10.0 in.</b> 25.4 cm

Notes:

1. CONTRAST measured as Mean Reflective Difference (MRD) at 650 nm.
2. Near ranges on largely depend on the width of the bar code and the scan angle.
3. Working range specifications: Photographic quality symbols, pitch = 15°, skew = 0°, roll = 0°, ambient light < 150 ft. candles, and temperature = 23 °C, Vcc = 5V.
4. Measured from the front of the scanner.

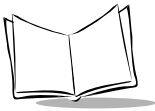
## 2D Slab/Raster Decode Distances

Note: Typical performance at 68°F (20°C)  
on high quality symbols in normal room light.  
Vcc = 5V



\* Minimum distance determined by symbol length and scan angle.

**Figure 4-4. MS-3207 2D Slab/Raster Decode Zone**



**Table 4-4. MS-3207 2D Slab/Raster Decode Distances**

Symbol Density/ Symbol p/n / Bar Code Type	Bar Code Content/ Contrast <sup>1</sup>	Typical Working Ranges <sup>3</sup>		Guaranteed Working Ranges <sup>3</sup>	
		Near	Far	Near	Far
6.6 mil 64-14035-01 2D	123 80% MRD	<b>1.0 in.</b> 2.54 cm	<b>5.25 in.</b> 13.34 cm	<b>1.5 in.</b> 3.8 cm	<b>3.75 in.</b> 9.5 cm
10 mil 64-14037-01 2D	ABCDEF 80% MRD	<b>3.5 in.</b> 8.89 cm	<b>9.5 in.</b> 24.13 cm	<b>5.0 in.</b> 12.7 cm	<b>7.5 in.</b> 9.5 cm
15 mil 64-14038-01 2D	012345678905 80% MRD	<b>6.5 in.</b> 16.51 cm	<b>14.0 in.</b> 35.6 cm	Note 2	<b>11.0 in.</b> 24.1 cm
55 mil 64-17458-01 1D	CD 80% MRD	<b>1.0 in.</b> 2.54 cm	<b>32 in.</b> 81.3 cm	Note 2	<b>22.0 in.</b> 55.9 cm
Notes: 1. CONTRAST measured as Mean Reflective Difference (MRD) at 650 nm. 2. Near ranges on largely depend on the width of the bar code and the scan angle. 3. Working range specifications: Photographic quality symbols, pitch = 15°, skew = 0°, roll = 0°, ambient light < 150 ft. candles, and temperature = 23 °C, Vcc = 5V. 4. Measured from the front of the scanner.					

## Usable Scan Length

The decode zone is a function of various symbol characteristics including density, print contrast, wide-to-narrow ratio, and edge acuity. Width of decode zone at any given distance must be considered when designing a system.

[Calculating The Usable Scan Length Method](#) on page 2-10 provides a detailed description of how to calculate the usable scan length. The scan angle is provided in [Table 4-2 on page 4-4](#).

## Application Notes

---

### ***TTL RS-232***

Standard RS-232 voltage levels typically range between +12V and -12V to ensure adequate noise rejection over long distances. Devices which support TTL level RS-232 signaling typically drive signals between 0V and +5V. Extensive testing has shown that TTL levels are interpreted correctly by the vast majority of standard RS-232 hosts over cable distances of six feet or less, even under extreme conditions.

Multi-interface Miniscan Plus products fall into the TTL RS-232 device category right out of the box. All standard RS-232 cables available from Symbol Technologies Inc. for the Miniscan Plus family measure six feet or less, and should not present a problem. In the event that a particular host does not support TTL levels, a separate conversion cable is available. This cable (25-62186-xx) contains electronics to adapt the TTL levels of a multi-interface Miniscan Plus into standard RS-232 levels.

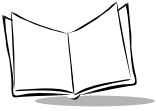
### ***USB Warning - Potential host side issues***

The Universal Serial Bus provides a smart plug and play interface for easy integration. The nature of USB is such that the root hub located on the host controls all traffic. All hosts are not created equal and it has been found that USB hosts in general react poorly in certain harsh environments compared to traditional host interfaces such as RS-232. These environments include areas with high levels of Electro Static Discharge (ESD) or situations in which the system is subject to Electrical Fast Transients (EFT).

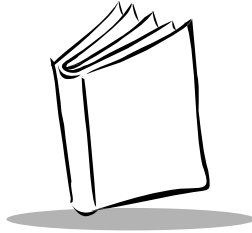
Typical symptoms that these conditions exist are:

1. Frequent scanner resets
2. Scanner sometimes loses power (Occurs due to host initiated shutdown)
3. Occasional host lockups

Multi-interface Miniscan Plus products are often exposed to such environments due to the nature of scanner placement, etc. As such all Miniscan Plus products have been safeguarded as much as possible against these phenomenon and will not suffer physical damage. Despite design precautions, testing has shown that some USB hosts cannot tolerate these types of disturbances. In these situations a self-powered USB hub placed close to the host, between the scanner and host, can sometimes serve as an effective buffer to the host against the harsh environment the USB scanner lives in. This may not be a valid solution in all cases.



*MiniScan MS-320X Integration Guide*



## Chapter 5 Scanning

### Overview

---

This chapter provides information on scanning and the various triggering options.

### Scanning Tips

---

When scanning, make sure the symbol to be scanned is within the scanning range. See [Calculating The Usable Scan Length Method](#) on page 2-10. Align the bar code with the scan beam. The green decode LED lights to indicate a successful decode.

#### ***Scan the Entire Symbol***

- The scan beam must cross every bar and space on the symbol.
- The larger the symbol, the farther away the scanner should be positioned.
- Position the scanner closer for symbols with bars that are close together.

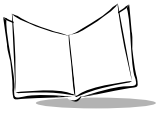
RIGHT



WRONG







## **Position at an Angle**

Do not position the scanner exactly perpendicular to the bar code. In this position, light can bounce back into the scanner's exit window and prevent a successful decode.

## **Triggering Options**

---

### ***Continuous (Default)***

The laser is enabled continuously and decode processing is continuously active. The scanner can be configured to scan and transmit a bar code, and then not decode the same bar code or any bar code for a set period of time. See [Timeout Between Decodes](#) on page 7-22 to customize the application to the rate at which bar codes are presented.



**Continuous**

---

**Note:** *This option is not recommended during scanner programming via bar code menus.*

---

### ***Level Trigger***

The laser is enabled and decode processing begins when the trigger line is activated. Decode processing continues until a good decode occurs, the trigger is released, or the Laser On Time expires. The laser is disabled once decode processing is complete. The next decode attempt will not occur until the trigger line is released and then reactivated.



**Level**

## ***Pulse Trigger***

The laser is enabled and decode processing begins when the trigger line is activated. Decode processing continues regardless of the trigger line until a good decode occurs, or until the Laser On Time expires. The laser is disabled once decode processing is complete. The next decode attempt will not occur until the trigger line is released and then reactivated.



**Pulse**

## ***Blinking***

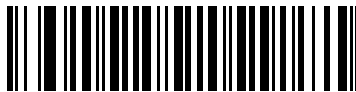
The laser blinks at a 25% duty cycle (reduced to 10% after 30 seconds of inactivity), until a bar code is presented. When a bar code is presented, the laser remains on until either the bar code is decoded or removed, or the session timeout expires. Once the bar code is decoded, the scanner will not decode it again until the bar code is removed.



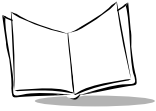
**Blinking**

## ***Host Trigger (MS-3204 Only)***

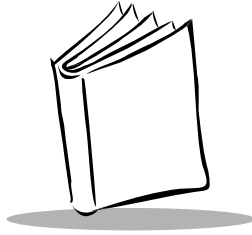
The laser is enabled and decode processing begins in response to an SSI Start Decode message from the host. Decode processing continues until a good decode occurs, an SSI Stop Decode message is received, or the Laser On Time expires. The laser is disabled once decode processing is complete. The next decode attempt will not occur until the next Start Decode message is received.



**Host**



*MiniScan MS-320X Integration Guide*



## Chapter 6

# *Maintenance and Troubleshooting*

### Overview

---

The chapter provides information on maintenance and troubleshooting.

### Maintenance

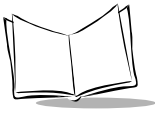
---

Cleaning the exit window is the only maintenance required. Do not allow any abrasive material to touch the window. Clean the scan window with a damp cloth and, if necessary, a non-ammonia based detergent.

### Troubleshooting

---

Problem	Possible Cause	Possible Solutions
No red LED or nothing happens when you attempt to scan.	No power to the scanner.	Check the system power. Confirm that the correct host interface cable is used.
		Connect the power supply.
		Re-connect loose cables.

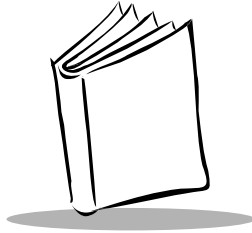


Problem	Possible Cause	Possible Solutions
Scanner cannot read the bar code	Interface/power cables are loose.	Re-connect loose cables.
	Scanner is not programmed for the correct bar code type.	Make sure the scanner is programmed to read the type of bar code to be scanned.  Try scanning other bar code(s) and other bar code types.
	Incorrect communication parameters.	Set the correct communication parameters (baud rate, parity, stop bits, etc.)
	Bar code symbol is unreadable.	Check the symbol to make sure it is not defaced. Try scanning similar symbols of the same code type.
	Inappropriately hot environment.	Remove the scanner from the hot environment, and allow it to cool down.
Laser activates, followed by a beep sequence.	Beeper is configured.	Refer to <a href="#">Table 1-1 on page 1-8</a> for beeper indication descriptions.
Scanner configured to USB host and does not scan (MS-3207 only).	Incorrect trigger mode selected.	Unplug scanner from USB host. Present Continuous Scan Mode bar code and plug unit in. Upon power up the MS-3207 scans briefly, decodes, and switches to continuous trigger mode.

---

**Note:** *If after performing these checks the symbol still does not scan, contact your distributor or call the Symbol Support Center. See [page xiii](#) for the telephone number.*

---



## Chapter 7

# Parameter Menus

This chapter describes the programmable parameters, and provides bar codes for programming and hexadecimal equivalents for host download programming.

Throughout the programming bar code menus, default values are indicated with asterisks (\*).



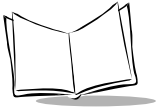
## Operational Parameters

---

The MS-3204 is shipped with the default settings shown in [Table 7-1 on page 7-3](#). These default values are stored in non-volatile memory and are preserved even when the scanner is powered down.

There are three ways to change the default values:

- Scan the appropriate bar codes in this chapter. These new values replace the standard default values in memory. To recall the default parameter values, scan the [Set All Defaults](#) bar code on page 7-11.
- Downloading data through the scanner's serial port using Symbol's Simple Serial Interface (SSI). This option is only available for MS-3204 models. Hexadecimal parameter numbers are shown in this chapter below the parameter title, and options are shown in parenthesis beneath the accompanying bar codes. See the



*Simple Serial Interface (SSI) Programmer's Guide* for detailed instructions for changing parameters using this method.

- Download data through the scanner's serial port using Symbol's 123Scan program. This option is only available for MS-3207 models. The 123Scan program uses a Windows-based interface to select and modify any of the parameters listed in the following pages. See [Chapter 10, 123Scan \(MS-3207 Only\)](#) for more information.

## Default Table

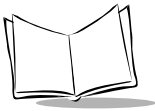
---

[Table 7-1](#) lists the defaults for all parameters, and the page number each parameter appears on. To change any option, scan the appropriate bar code(s).

Table 7-1. Default Table

Parameter	Parameter Number	Default	Page Number
Set Default Parameter		All Defaults	7-11
<b>Scanning Options</b>			
Beeper Volume	8Ch	High Volume	7-12
Beeper Tone	91h	High Frequency	7-13
Beeper Frequency Adjustment	F0h 91h	2500 Hz	7-14
Laser On Time	88h	5.0 sec	7-15
Power Mode	80h	Low Power	7-16
Trigger Mode	8Ah	MS-3204: Level MS-3207: Continuous	7-17
Scanning Mode	8Dh	MS-3204: Smart Raster MS-3207: Omnidirectional	7-19
Aiming Mode	F0h 7Eh	Disabled	7-19
Raster Height	E4h	15	7-21
Raster Expansion Rate	E5h	11	7-21
Time-out Between Same Symbol	89h	0.6 sec	7-22
Time-out Between Different Symbols	90h	0.0 sec	7-22
Beep After Good Decode	38h	Enable	7-23
Transmit "No Decode" Message	5Eh	Disable	7-24
Parameter Scanning	ECh	Enable	7-25
Linear Code Type Security Levels	4Eh	2	7-26



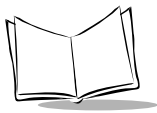


**Table 7-1. Default Table (Continued)**

Parameter	Parameter Number	Default	Page Number
Bi-directional Redundancy	43h	Disable	<a href="#">7-28</a>
<b>UPC/EAN</b>			
UPC-A	01h	Enable	<a href="#">7-29</a>
UPC-E	02h	Enable	<a href="#">7-29</a>
UPC-E1	0Ch	Disable	<a href="#">7-31</a>
EAN-8	04h	Enable	<a href="#">7-32</a>
EAN-13	03h	Enable	<a href="#">7-33</a>
Bookland EAN	53h	Disable	<a href="#">7-34</a>
UPC/EAN Coupon Code	55h	Disable	<a href="#">7-35</a>
Decode UPC/EAN Supplementals	10h	Ignore	<a href="#">7-36</a>
Decode UPC/EAN Supplemental Redundancy	50h	20	<a href="#">7-38</a>
Transmit UPC-A Check Digit	28h	Enable	<a href="#">7-39</a>
Transmit UPC-E Check Digit	29h	Enable	<a href="#">7-40</a>
Transmit UPC-E1 Check Digit	2Ah	Enable	<a href="#">7-41</a>
UPC-A Preamble	22h	System Character	<a href="#">7-42</a>
UPC-E Preamble	23h	System Character	<a href="#">7-43</a>
UPC-E1 Preamble	24h	System Character	<a href="#">7-44</a>
Convert UPC-E to A	25h	Disable	<a href="#">7-45</a>
Convert UPC-E1 to A	26h	Disable	<a href="#">7-46</a>
EAN-8 Zero Extend	27h	Disable	<a href="#">7-47</a>

Table 7-1. Default Table (Continued)

Parameter	Parameter Number	Default	Page Number
UPC/EAN Security Level	4Dh	0	<a href="#">7-48</a>
Linear UPC/EAN Decode	44h	Disable	<a href="#">7-50</a>
<b>Code 128</b>			
Code 128	08h	Enable	<a href="#">7-51</a>
UCC/EAN-128	0Eh	Enable	<a href="#">7-52</a>
ISBT 128	54h	Disable	<a href="#">7-53</a>
Code 128 Decode Performance	48h	Enable	<a href="#">7-54</a>
Code 128 Decode Performance Level	49h	Level 3	<a href="#">7-55</a>
<b>Code 39</b>			
Code 39	00h	Enable	<a href="#">7-56</a>
Trioptic Code 39	0Dh	Disable	<a href="#">7-57</a>
Convert Code 39 to Code 32	56h	Disable	<a href="#">7-58</a>
Code 32 Prefix	E7h	Enable	<a href="#">7-59</a>
Set Length(s) for Code 39	12h 13h	Length within Range: 01-55	<a href="#">7-60</a>
Code 39 Check Digit Verification	30h	Disable	<a href="#">7-62</a>
Transmit Code 39 Check Digit	2Bh	Disable	<a href="#">7-63</a>
Code 39 Full ASCII Conversion	11h	Disable	<a href="#">7-64</a>
Code 39 Decode Performance	46h	Enable	<a href="#">7-65</a>
Code 39 Decode Performance Level	47h	Level 3	<a href="#">7-66</a>

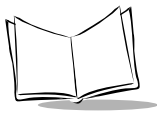


**Table 7-1. Default Table (Continued)**

Parameter	Parameter Number	Default	Page Number
<b>Code 93</b>			
Code 93	09h	Disable	<a href="#">7-67</a>
Set Length(s) for Code 93	1Ah 1Bh	Length within Range: 04-55	<a href="#">7-68</a>
<b>Code 11</b>			
Code 11	0Ah	Disable	<a href="#">7-70</a>
Set Length(s) for Code 11	1Ch, 1Dh	Length within Range: 04-55	<a href="#">7-71</a>
Code 11 Check Digit Verification	34h	Disable	<a href="#">7-73</a>
Transmit Code 11 Check Digits	2Fh	Disable	<a href="#">7-74</a>
<b>Interleaved 2 of 5</b>			
Interleaved 2 of 5	06h	Disable	<a href="#">7-75</a>
Set Length(s) for I 2 of 5	16h 17h	1 Discrete Length: 14	<a href="#">7-76</a>
I 2 of 5 Check Digit Verification	31h	Disable	<a href="#">7-78</a>
Transmit I 2 of 5 Check Digit	2Ch	Disable	<a href="#">7-79</a>
Convert I 2 of 5 to EAN 13	52h	Disable	<a href="#">7-80</a>
<b>Discrete 2 of 5</b>			
Discrete 2 of 5	05h	Disable	<a href="#">7-81</a>
Set Length(s) for D 2 of 5	14h 15h	1 Discrete Length: 12	<a href="#">7-82</a>

Table 7-1. Default Table (Continued)

Parameter	Parameter Number	Default	Page Number
<b>Codabar</b>			
Codabar	07h	Disable	<a href="#">7-84</a>
Set Lengths for Codabar	18h 19h	Length within Range: 05-55	<a href="#">7-85</a>
CLSI Editing	36h	Disable	<a href="#">7-87</a>
NOTIS Editing	37h	Disable	<a href="#">7-88</a>
<b>MSI Plessey</b>			
MSI Plessey	0Bh	Disable	<a href="#">7-89</a>
Set Length(s) for MSI Plessey	1Eh 1Fh	Length Within Range: 06 - 55	<a href="#">7-90</a>
MSI Plessey Check Digits	32h	One	<a href="#">7-92</a>
Transmit MSI Plessey Check Digit	2Eh	Disable	<a href="#">7-93</a>
MSI Plessey Check Digit Algorithm	33h	Mod 10/Mod 10	<a href="#">7-94</a>
<b>PDF417/MicroPDF417</b>			
PDF417	0Fh	MS-3204: Enable MS-3207: Disable	<a href="#">7-95</a>
MicroPDF417	E3h	Disable	<a href="#">7-96</a>
MicroPDF Performance	F0h 65h	Standard	<a href="#">7-97</a>
Code 128 Emulation	7Bh	Disable	<a href="#">7-98</a>
<b>RSS</b>			
RSS-14	F0h 52h	Disable	<a href="#">7-99</a>

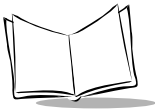


**Table 7-1. Default Table (Continued)**

Parameter	Parameter Number	Default	Page Number
RSS Limited	F0h 53h	Disable	<a href="#">7-100</a>
RSS Expanded	F0h 54h	Disable	<a href="#">7-101</a>
<b>Composite (MS-3204 Only)</b>			
CC-C	F0h 55h	Disable	<a href="#">7-102</a>
CC-AB	F0h 56h	Disable	<a href="#">7-103</a>
TLC-39	F0h 73h	Disable	<a href="#">7-104</a>
UPC Composite Mode	F0h 58h	Always Linked	<a href="#">7-105</a>
<b>Data Options</b>			
Transmit Code ID Character	2Dh	None	<a href="#">7-106</a>
Prefix/Suffix Values			<a href="#">7-108</a>
Prefix	69h	NULL	
Suffix 1	68h	CR	
Suffix 2	6Ah	LF	
Scan Data Transmission Format (MS-3204)	EBh	Data as is	<a href="#">7-110</a>
Scan Data Transmission Format (MS-3207)	N/A	Data as is	<a href="#">7-112</a>
<b>Simple Serial Interface (SSI) Options</b>			
Baud Rate	9Ch	9600	<a href="#">7-114</a>
Parity	9Eh	None	<a href="#">7-116</a>
Check Parity	97h	Enable	<a href="#">7-118</a>
Software Handshaking	9Fh	ACK/NAK	<a href="#">7-119</a>

Table 7-1. Default Table (Continued)

Parameter	Parameter Number	Default	Page Number
Host RTS Line State	9Ah	Low	<a href="#">7-120</a>
Decode Data Packet Format	EEh	Unpacketed	<a href="#">7-121</a>
Stop Bit Select	9Dh	1	<a href="#">7-122</a>
Intercharacter Delay	6Eh	0	<a href="#">7-123</a>
Host Serial Response Time-out	9Bh	2 sec	<a href="#">7-123</a>
Host Character Time-out	EFh	200 msec	<a href="#">7-124</a>
<b>Event Reporting</b>			
Decode Event	F0h 00h	Disable	<a href="#">7-125</a>
Boot Up Event	F0h 02h	Disable	<a href="#">7-126</a>
Parameter Event	F0h 03h	Disable	<a href="#">7-127</a>
<b>Macro PDF</b>			
Transmit Each Symbol in Codeword Format	Afh	Disable	<a href="#">7-128</a>
Transmit Unknown Codewords	BAh	Disable	<a href="#">7-130</a>
Escape Character	E9h	None	<a href="#">7-131</a>
<b>ECI</b>			
Delete Character Set ECIs	E6h	Enable	<a href="#">7-132</a>
ECI Decoder	E8h	Enable	<a href="#">7-133</a>
<b>Transmit Macro PDF User-Selected Field</b>			
Transmit File Name	B0h	Disable	<a href="#">7-134</a>
Transmit Block Count	B1h	Disable	<a href="#">7-135</a>



**Table 7-1. Default Table (Continued)**

<b>Parameter</b>	<b>Parameter Number</b>	<b>Default</b>	<b>Page Number</b>
Transmit Time Stamp	B2h	Disable	<a href="#">7-136</a>
Transmit Sender	B3h	Disable	<a href="#">7-137</a>
Transmit Addressee	B4h	Disable	<a href="#">7-138</a>
Transmit Checksum	B6h	Disable	<a href="#">7-139</a>
Transmit File Size	B5h	Disable	<a href="#">7-140</a>
Transmit Macro PDF Control Header	B7h	Disable	<a href="#">7-141</a>
Last Block Marker	B9h	Disable	<a href="#">7-142</a>

## Set Default Parameter

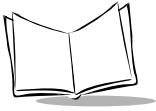
---

Scanning this bar code returns all parameters to the values listed in [Table 7-1 on page 7-3](#).



**Set All Defaults**





## Scanning Options

---

### ***Beeper Volume***

#### ***Parameter # 8Ch***

To select a decode beep volume, scan the **Low Volume**, **Medium Volume**, or **High Volume** bar code.



**Low Volume**



**Medium Volume**

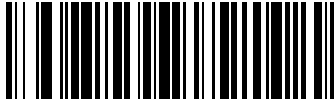


**\*High Volume**

## ***Beeper Tone***

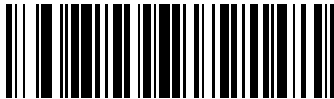
### ***Parameter # 91h***

To select a decode beep frequency (tone), scan the appropriate bar code.



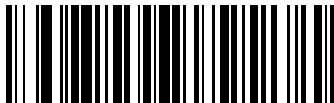
**Low Frequency**

**(02h)**



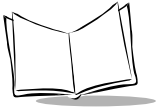
**Medium Frequency**

**(01h)**



**\*High Frequency**

**(00h)**



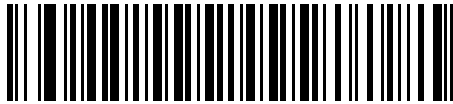
## **Beeper Frequency Adjustment**

### **Parameter # F0h 91h**

This parameter adjusts the frequency of the high beeper tone from the nominal 2500 Hz to another frequency matching the resonances of the installation. It is programmable in 10 Hz increments from 1220 Hz to 3770 Hz.

To increase the frequency, scan the bar code below, then scan three numeric bar codes beginning on [page 7-143](#) that correspond to the desired frequency adjustment divided by 10. For example, to set the frequency to 3000 Hz (an increase of 500 Hz), scan numeric bar codes 0, 5, 0, corresponding to 50, or (500/10).

To decrease the frequency, scan the bar code below, then scan three numeric bar codes beginning on [page 7-143](#) that correspond to the value (256 - desired adjustment/10). For example, to set the frequency to 2000 Hz (a decrease of 500 Hz), scan numeric bar codes 2, 0, 6, corresponding to 206, or (256 - 500/10).



**Beeper Frequency Adjustment**

**(Default: 2500 Hz)**

## **Laser On Time**

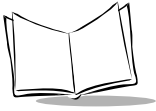
### **Parameter # 88h**

This parameter sets the maximum time decode processing continues during a scan attempt. It is programmable in 0.1 second increments from 0.5 to 9.9 seconds.

To set a Laser On Time, scan the bar code below. Next scan two numeric bar codes beginning on [page 7-143](#) that correspond to the desired on time. Times less than 1.0 second must have a leading zero. For example, to set an on time of 0.5 seconds, scan the bar code below, then scan the “0” and “5” bar codes. To change the selection or to cancel an incorrect entry, scan the [Cancel](#) bar code on [page 7-145](#).



**Laser On Time**



## **Power Mode**

### **Parameter # 80h**

This parameter determines whether or not power remains on after a decode attempt. In Low Power mode, the scanner enters into a low power consumption mode when possible, provided all WAKEUP signals are released. In Continuous On mode, power remains on after each decode attempt.



**Continuous On**

**(00h)**



**\*Low Power**

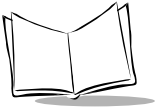
**(01h)**

## **Triggering Modes**

### **Parameter # 8Ah**

Choose one of the options below to trigger the scanner. Bar codes and option numbers are on the following page.

- **Level** - A trigger pull activates the laser and decode processing. The laser remains on and decode processing continues until a trigger release, a valid decode, or the Laser On Time-out is reached.
- **Pulse** - A trigger pull activates the laser and decode processing. The laser remains on and decode processing continues until a valid decode or the Laser On Time-out is reached.
- **Continuous** - The laser is always on and decoding.
- **Blinking** - This trigger mode is used for triggerless ScanStand operation. Scanning range is reduced in this mode. This mode cannot be used with scanners that support an aim mode.
- **Host** - A host command issues the triggering signal. The scanner interprets an actual trigger pull as a Level triggering option.



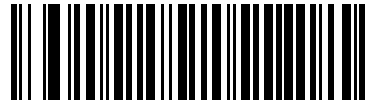
**Level  
(00h)**



**Pulse  
(02h)**



**Continuous  
(04h)**



**Blinking  
(07h)**



**Host  
(08h)**

## Scanning Mode

### Parameter # 8Dh

Select one of the following scanning modes:

---

**Note:** *Not available in MS 3204.*

---

- Smart Raster
- Slab Only Raster
- Omnidirectional (Cyclone)
- Always Raster
- Programmable Raster
- Semi-Omnidirectional

---

**Note:** *If Omnidirectional is selected, disabling the following parameters is recommended: PDF417, MicroPDF417, RSS-Limited, CC-C, CC-AB, TLC-39 and Linear UPC.*

---



Smart Raster  
(01h)



Always Raster  
(02h)



Programmable Raster  
(03h)



Slab Pattern  
(04h)

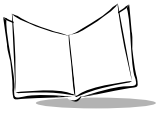


\*Omnidirectional Pattern  
(06h)



Semi-Omni Pattern  
(07h)





## Aiming Mode

### Parameter # F0h 7Eh

For handheld mode only, select an aiming dot to appear for a normal or extended period of time.

---

**Note:** Not available in MS 3201-E000

---



**\*No Aiming Dot  
(00h)**



**Aiming Dot  
Normal (200 ms) Timeout  
(01h)**



**Aiming Dot  
Extended (400 ms) Timeout  
(02h)**

## **Programmable Raster Height And Raster Expansion Speed**

### **Parameter # E4h, E5h**

This parameter selects the laser pattern's height and rate of expansion, and is only used when Programmable Raster or Always Raster is enabled. This parameter is intended for very specific applications, and is usually not necessary.

Select the laser pattern's height and/or rate of expansion.

1. Scan the bar code for either **Raster Height** or **Raster Expansion Speed** below.
2. Scan two numeric bar codes beginning on [page 7-143](#) that represent a two-digit value. Valid values are between 01 and 15.

To change the selection or to cancel an incorrect entry, scan *Cancel* on page 7-145.

---

**Note:** *Not available in MS 3204-E000*

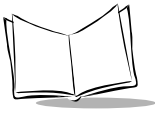
---



**Raster Height (Default 15)**



**Raster Expansion Speed (Default 11)**



## **Timeout Between Decodes**

### **Timeout Between Decodes, Same Symbol**

#### **Parameter # 89h**

When in Continuous triggering mode, this parameter sets the minimum duration of not decoding data before the scanner decodes a second bar code identical to one just decoded. This reduces the risk of accidentally scanning the same symbol twice. It is programmable in 0.1 second increments from 0.0 to 9.9 seconds. The recommended interval is 0.6 seconds

### **Timeout Between Decodes, Different Symbol**

#### **Parameter # 90h**

This option sets the minimum duration of not decoding data before the scanner decodes a second (different) bar code. This option is used in Continuous mode to prevent the beeper from beeping when a different symbol appears in the scanner's field of view before the timeout period between decodes expires. This is programmable in 0.1 second increments from 0.0 to 9.9 seconds. The recommended value is 0.0 seconds.

Select the timeout between decodes for the same or different symbols.

1. Scan the option bar code you wish to set.
2. Scan two numeric bar codes beginning on [page 7-143](#) which correspond to the desired interval, in 0.1 second increments.

To change the selection or to cancel an incorrect entry, scan *Cancel* on page 7-145.



**Timeout Between Decodes -  
The Same Symbol**



**Timeout Between Decodes -  
Different Symbols**

## ***Beep After Good Decode***

### ***Parameter # 38h***

Scan this symbol if you want the scanner to beep after a good decode.



**\*Beep After Good Decode**

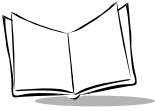
**(01h)**

Scan this symbol if you do not want the scanner to beep after a good decode. The beeper still operates during parameter menu scanning and indicates error conditions.



**Do Not Beep After Good Decode**

**(00h)**



## **Transmit “No Read” Message**

### **Parameter # 5Eh**

When enabled, if a 1-D symbol does not decode, “NR” is transmitted. If a 2-D symbol does not decode, “FR” is transmitted. Any prefix or suffixes which have been enabled are appended around this message.



**Enable No Read**

**(01h)**

When disabled, if a symbol does not read, nothing is sent to the host.



**\*Disable No Read**

**(00h)**

## ***Parameter Scanning***

### ***Parameter # ECh***

To disable decoding of parameter bar codes, scan the bar code below. Note that the Set Defaults parameter bar code will still be decoded. To enable decoding of parameter bar codes, either scan *\*Enable Parameter Scanning*, *Set All Defaults* or set this parameter to 01h via a serial command.



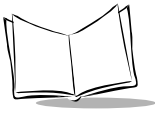
**\*Enable Parameter Scanning**

**(01h)**



**Disable Parameter Scanning**

**(00h)**



## Linear Code Type Security Level

### Parameter # 4Eh

---

**Note:** Does not apply to Code 128.

---

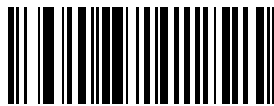
The MS-320x offers four levels of decode security for linear code types (e.g., Code 39, Interleaved 2 of 5). Select higher security levels for decreasing levels of bar code quality. As security levels increase, the scanner's aggressiveness decreases.

Select the security level appropriate for bar code quality.

### Linear Security Level 1

The following code types must be successfully read twice before being decoded:

Code Type	Length
Codabar	All
MSI Plessey	4 or less
D 2 of 5	8 or less
I 2 of 5	8 or less



**Redundancy Level 1**  
(01h)

### Linear Security Level 2

All code types must be successfully read twice before being decoded.



**\*Redundancy Level 2**  
(02h)

### Linear Security Level 3

Code types other than the following must be successfully read twice before being decoded. The following codes must be read three times:

Code Type	Length
MSI Plessey	4 or less
D 2 of 5	8 or less
I 2 of 5	8 or less

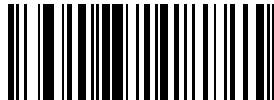


**Redundancy Level 3**

**(03h)**

### Linear Security Level 4

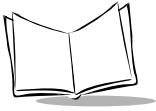
All code types must be successfully read three times before being decoded.



**Redundancy Level 4**

**(04h)**





## ***Bi-directional Redundancy***

### **Parameter # 43h**

This parameter is only valid when a [Linear Code Type Security Level](#) is enabled (see [page 7-26](#)). When this parameter is enabled, a bar code must be successfully scanned in both directions (forward and reverse) before being decoded.



**Enable Bi-directional Redundancy**

**(01h)**



**\*Disable Bi-directional Redundancy**

**(00h)**

## UPC/EAN

---

### ***Enable/Disable UPC-A***

#### ***Parameter # 01h***

To enable or disable UPC-A, scan the appropriate bar code below.



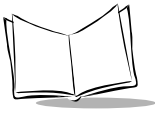
**\*Enable UPC-A**

**(01h)**



**Disable UPC-A**

**(00h)**



## **Enable/Disable UPC-E**

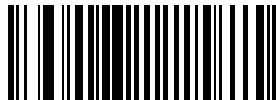
### **Parameter # 02h**

To enable or disable UPC-E, scan the appropriate bar code below.



**\*Enable UPC-E**

**(01h)**



**Disable UPC-E**

**(00h)**

## **Enable/Disable UPC-E1**

### **Parameter # 0Ch**

To enable or disable UPC-E1, scan the appropriate bar code below.



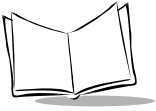
**Enable UPC-E1**

**(01h)**



**\*Disable UPC-E1**

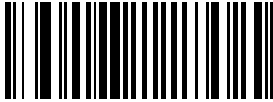
**(00h)**



## **Enable/Disable EAN-8**

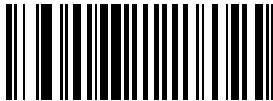
### **Parameter # 04h**

To enable or disable EAN-8, scan the appropriate bar code below.



**\*Enable EAN-8**

**(01h)**



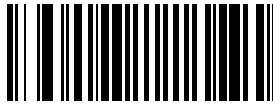
**Disable EAN-8**

**(00h)**

## **Enable/Disable EAN-13**

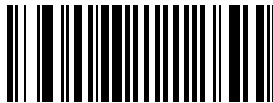
### **Parameter # 03h**

To enable or disable EAN-13, scan the appropriate bar code below.



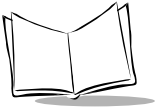
**\*Enable EAN-13**

**(01h)**



**Disable EAN-13**

**(00h)**



## **Enable/Disable Bookland EAN**

### **Parameter # 53h**

To enable or disable EAN Bookland, scan the appropriate bar code below.



**Enable Bookland EAN**

**(01h)**



**\*Disable Bookland EAN**

**(00h)**

## **UPC/EAN Coupon Code**

### **Parameter # 55h**

When enabled, this parameter decodes UPC-A bar codes starting with digit '5', EAN-13 bar codes starting with digit '99', and UPC-A/EAN-128 Coupon Codes. UPC-A, EAN-13 and EAN-128 must be enabled to scan all types of Coupon Codes.



**Enable UPC/EAN  
Coupon Code**



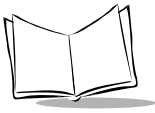
**\*Disable UPC/EAN  
Coupon Code**

---

**Note:** Use the *Decode UPC/EAN Supplemental Redundancy* parameter to control autodiscrimination of the EAN-128 (right half) of a coupon code.

---





## Decode UPC/EAN Supplementals

### Parameter # 10h

Supplementals are additionally appended characters (2 or 5) according to specific code format conventions (e.g., UPC A+2, UPC E+2, EAN 8+2). Three options are available.

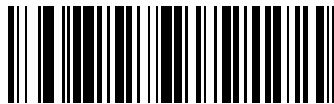
- If **UPC/EAN with supplemental characters** is selected, the scanner does not decode UPC/EAN symbols without supplemental characters.
- If **UPC/EAN without supplemental characters** is selected, and the MS-320x is presented with a UPC/EAN plus supplemental symbol, the scanner decodes the UPC/EAN and ignores the supplemental characters.
- If **autodiscriminate** is selected, scan [Decode UPC/EAN Supplemental Redundancy](#) on [page 7-38](#), then select a value from the numeric bar codes beginning on [page 7-143](#). A value of 5 or more is recommended.
- If **Enable 378/379 Supplemental Mode** is selected, the scanner identifies supplementals for EAN-13 bar codes starting with a '378' or '379' prefix only. All other UPC/EAN bar codes are decoded immediately and the supplemental characters ignored.
- If **Enable 978 Supplemental Mode** is selected, the scanner identifies supplementals for EAN-13 bar codes starting with a '978' prefix only. All other UPC/EAN bar codes are decoded immediately and the supplemental characters ignored.
- If **Enable Smart Supplemental Mode** is selected, the scanner identifies supplementals for EAN-13 bar codes starting with a '378', '379', or '978' prefix only. All other UPC/EAN bar codes are decoded immediately and the supplemental characters ignored.

---

**Note:** *To minimize the risk of invalid data transmission, we recommend selecting either read or ignore supplemental characters.*

---

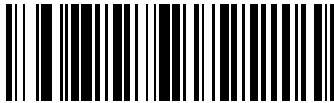
Select the desired option by scanning one of the following bar codes.



Decode UPC/EAN With Supplementals

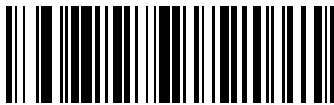
(01h)

## ***Decode UPC/EAN Supplementals (continued)***



**\*Ignore UPC/EAN With Supplementals**

**(00h)**



**Autodiscriminate UPC/EAN Supplementals**

**(02h)**



**Enable 378/379 Supplemental Mode**

**(04h)**



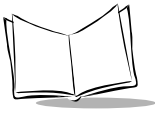
**Enable 978 Supplemental Mode**

**(05h)**



**Enable Smart Supplemental Mode**

**(03h)**

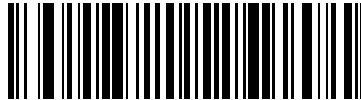


## **Decode UPC/EAN Supplemental Redundancy**

### **Parameter # 50h**

With *Autodiscriminate UPC/EAN Supplementals* selected, this option adjusts the number of times (from 2 to 20) a symbol without supplementals is decoded before transmission. Five or above is recommended when decoding a mix of UPC/EAN symbols with and without supplementals, and the autodiscriminate option is selected.

Scan the bar code below to select a decode redundancy value. Next scan two numeric bar codes beginning on [page 7-143](#). Single digit numbers must have a leading zero. To change the selection or to cancel an incorrect entry, scan the *Cancel* bar code on [page 7-145](#).

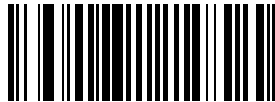


**Decode UPC/EAN  
Supplemental Redundancy**

## **Transmit UPC-A Check Digit**

### **Parameter # 28h**

Scan the appropriate bar code below to transmit the symbol with or without the UPC-A check digit.



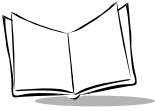
**\*Transmit UPC-A Check Digit**

**(01h)**



**Do Not Transmit UPC-A Check Digit**

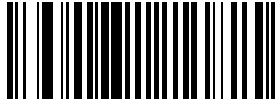
**(00h)**



## **Transmit UPC-E Check Digit**

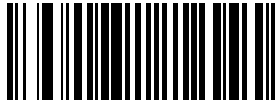
### **Parameter # 29h**

Scan the appropriate bar code below to transmit the symbol with or without the UPC-E check digit.



**\*Transmit UPC-E Check Digit**

**(01h)**



**Do Not Transmit UPC-E Check Digit**

**(00h)**

## **Transmit UPC-E1 Check Digit**

### **Parameter # 2Ah**

Scan the appropriate bar code below to transmit the symbol with or without the UPC-E1 check digit.



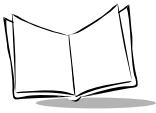
**\*Transmit UPC-E1 CHECK DIGIT**

**(01h)**



**Do Not Transmit UPC-E1 Check Digit**

**(00h)**



## UPC-A Preamble

### Parameter # 22h

Preamble characters (Country Code and System Character) can be transmitted as part of a UPC-A symbol. Select one of the following options for transmitting UPC-A preamble to the host device: transmit system character only, transmit system character and country code ("0" for USA), or transmit no preamble.



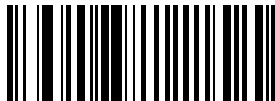
**No Preamble**  
(<DATA>)

(00h)



**\*System Character**  
(<SYSTEM CHARACTER> <DATA>)

(01h)



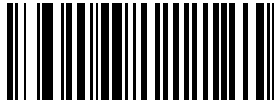
**System Character & Country Code**  
(< COUNTRY CODE> <SYSTEM CHARACTER> <DATA>)

(02h)

## UPC-E Preamble

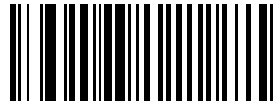
### Parameter # 23h

Preamble characters (Country Code and System Character) can be transmitted as part of a UPC-E symbol. Select one of the following options for transmitting UPC-E preamble to the host device: transmit system character only, transmit system character and country code ("0" for USA), or transmit no preamble.



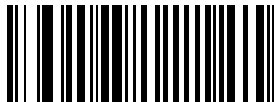
**No Preamble**  
(<DATA>)

(00h)



**\*System Character**  
(<SYSTEM CHARACTER> <DATA>)

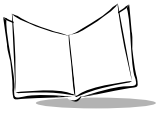
(01h)



**System Character & Country Code**  
(< COUNTRY CODE> <SYSTEM CHARACTER> <DATA>)

(02h)





## UPC-E1 Preamble

### Parameter # 24h

Preamble characters (Country Code and System Character) can be transmitted as part of a UPC-E1 symbol. Select one of the following options for transmitting UPC-E1 preamble to the host device: transmit system character only, transmit system character and country code ("0" for USA), or transmit no preamble.



**No Preamble**  
(<DATA>)

(00h)



**\*System Character**  
(<SYSTEM CHARACTER> <DATA>)

(01h)



**System Character & Country Code**  
(< COUNTRY CODE> <SYSTEM CHARACTER> <DATA>)

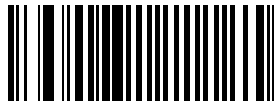
(02h)

## **Convert UPC-E to UPC-A**

### **Parameter # 25h**

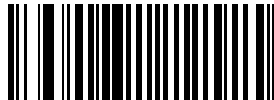
This parameter converts UPC-E (zero suppressed) decoded data to UPC-A format before transmission. After conversion, data follows UPC-A format and is affected by UPC-A programming selections (e.g., Preamble, Check Digit).

Scan **DO NOT CONVERT UPC-E TO UPC-A** to transmit UPC-E (zero suppressed) decoded data.



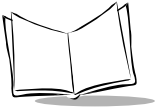
**Convert UPC-E To UPC-A  
(Enable)**

**(01h)**



**\*Do Not Convert UPC-E To UPC-A  
(Disable)**

**(00h)**



## Convert UPC-E1 to UPC-A

### Parameter # 26h

Enable this parameter to convert UPC-E1 (zero suppressed) decoded data to UPC-A format before transmission. After conversion, data follows UPC-A format and is affected by UPC-A programming selections (e.g., Preamble, Check Digit).

Scan **DO NOT CONVERT UPC-E TO UPC-A** to transmit UPC-E1 (zero suppressed) decoded data.



**Convert UPC-E1 To UPC-A  
(Enable)**

**(01h)**



**\*Do Not Convert UPC-E1 To UPC-A  
(Disable)**

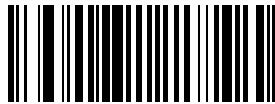
**(00h)**

## ***EAN Zero Extend***

### ***Parameter # 27h***

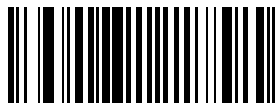
When this parameter is enabled, five leading zeros are added to decoded EAN-8 symbols to make them compatible in format to EAN-13 symbols.

Disable this parameter to transmit EAN-8 symbols as is.



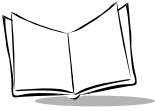
**Enable EAN Zero Extend**

**(01h)**



**\*Disable EAN Zero Extend**

**(00h)**



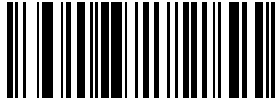
## **UPC/EAN Security Level**

### **Parameter # 4Dh**

The MS-320x offers four levels of decode security for UPC/EAN bar codes. Select higher levels of security for decreasing levels of bar code quality. Increasing security decreases the scanner's aggressiveness, so choose only that level of security necessary for the application.

### **UPC/EAN Security Level 0**

This default setting allows the scanner to operate in its most aggressive state, while providing sufficient security in decoding "in-spec" UPC/EAN bar codes.



**\*Security Level 0**

**(00h)**

### **UPC/EAN Security Level 1**

Select this option if misdecodes occur. This security level eliminates most misdecodes.



**Security Level 1**

**(01h)**

## UPC/EAN Security Level 2

Select this option if Security level 1 fails to eliminate misdecodes.

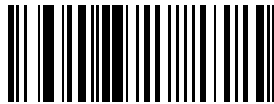


**Security Level 2**

**(02h)**

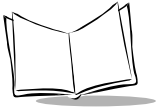
## UPC/EAN Security Level 3

If misdecodes still occur after selecting Security Level 2, select this security level. Be advised, selecting this option is an extreme measure against misdecoding severely out of spec bar codes. Selecting this level of security significantly impairs the decoding ability of the scanner. If this level of security is necessary, try to improve the quality of the bar codes.



**Security Level 3**

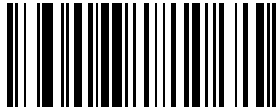
**(03h)**



## **Linear UPC/EAN Decode**

### **Parameter # 44h**

This option applies to code types containing two adjacent blocks (e.g., UPC-A, EAN-8, EAN-13). When enabled, a bar code is transmitted only when both the left and right blocks are successfully decoded within one laser scan. Enable this option when bar codes are in proximity to each other.



**Enable Linear UPC/EAN Decode**

**(01h)**



**\*Disable Linear UPC/EAN Decode**

**(00h)**

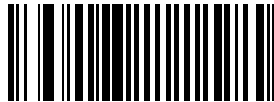
## Code 128

---

### *Enable/Disable Code 128*

#### *Parameter # 08h*

To enable or disable Code 128, scan the appropriate bar code below.



**\*Enable Code 128**

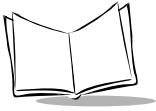
**(01h)**



**Disable Code 128**

**(00h)**

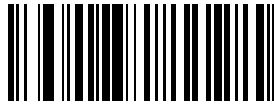




## **Enable/Disable UCC/EAN-128**

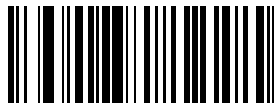
### **Parameter # 0Eh**

To enable or disable UCC/EAN-128, scan the appropriate bar code below.



**\*Enable UCC/EAN-128**

**(01h)**



**Disable UCC/EAN-128**

**(00h)**

## ***Enable/Disable ISBT 128***

### ***Parameter # 54h***

To enable or disable ISBT 128, scan the appropriate bar code below.



**Enable ISBT 128**

**(01h)**

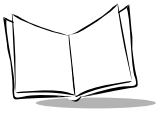


**\*Disable ISBT 128**

**(00h)**

### ***Lengths for Code 128***

No length setting is required for Code 128.



## **Code 128 Decode Performance**

### **Parameter # 48h**

This option offers three levels of decode performance or “aggressiveness” for Code 128 symbols. Increasing the performance level reduces the amount of required bar code orientation, which is useful when scanning very long and/or truncated bar codes. Increased levels reduce decode security.

If you enable this option, you can select a Decode Performance level from the next page to suit performance needs.



**\*Enable Code 128 Decode Performance**

**(01h)**



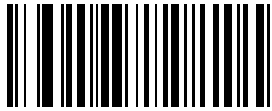
**Disable Code 128 Decode Performance**

**(00h)**

## **Code 128 Decode Performance Level**

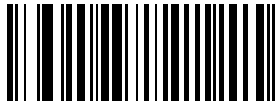
### **Parameter # 49h**

Select a level of decode performance.



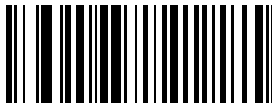
**Code 128 Decode Performance Level 1**

**(03h)**



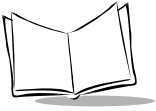
**Code 128 Decode Performance Level 2**

**(02h)**



**\*Code 128 Decode Performance Level 3**

**(01h)**



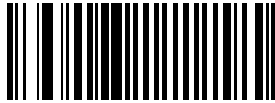
## Code 39

---

### ***Enable/Disable Code 39***

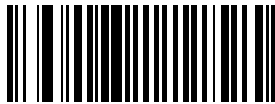
#### ***Parameter # 00h***

To enable or disable Code 39, scan the appropriate bar code below.



**\*Enable Code 39**

**(01h)**



**Disable Code 39**

**(00h)**

## **Enable/Disable Trioptic Code 39**

### **Parameter # 0Dh**

Trioptic Code 39 is a variant of Code 39 used in marking computer tape cartridges. Trioptic Code 39 symbols always contain six characters. Do not enable Trioptic Code 39 and Code 39 Full ASCII simultaneously.

To enable or disable Trioptic Code 39, scan the appropriate bar code below.



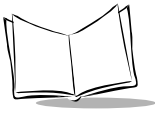
**Enable Trioptic Code 39**

**(01h)**



**\*Disable Trioptic Code 39**

**(00h)**



## **Convert Code 39 to Code 32**

### **Parameter # 56h**

Code 32 is a variant of Code 39 used by the Italian pharmaceutical industry. Scan the appropriate bar code below to enable or disable converting Code 39 to Code 32.

---

**Note:** Code 39 must be enabled for this parameter to function.

---



**Convert Code 39 To Code 32  
(Enable)**

**(01h)**



**\*Do Not Convert Code 39 To Code 32  
(Disable)**

**(00h)**

## Code 32 Prefix

### Parameter # E7h

Enable this parameter to add the prefix character "A" to all Code 32 bar codes. [Convert Code 39 to Code 32](#) must be enabled for this parameter to function.



**\*Enable Code 32 Prefix**

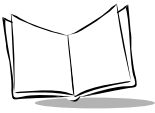
**(01h)**



**Disable Code 32 Prefix**

**(00h)**





## Set Lengths for Code 39

### Parameter # L1 = 12h, L2 = 13h

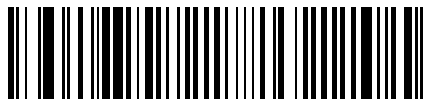
The length of a code refers to the number of characters (i.e., human readable characters), including check digit(s) the code contains. Lengths for Code 39 may be set for any length, one or two discrete lengths, or lengths within a specific range. If Code 39 Full ASCII is enabled, **Length Within a Range** or **Any Length** are the preferred options.

**One Discrete Length** - This option limits decodes to only those Code 39 symbols containing a selected length. Lengths are selected from the numeric bar codes beginning on [page 7-143](#). For example, to decode only Code 39 symbols with 14 characters, scan **Code 39 - One Discrete Length**, then scan **1** followed by **4**. To change the selection or cancel an incorrect entry, scan the *Cancel* bar code on [page 7-145](#).



Code 39 - One Discrete Length

**Two Discrete Lengths** - This option limits decodes to only those Code 39 symbols containing either of two selected lengths. Lengths are selected from the numeric bar codes beginning on [page 7-143](#). For example, to decode only those Code 39 symbols containing either 2 or 14 characters, select **Code 39 - Two Discrete Lengths**, then scan **0**, **2**, **1**, and then **4**. To change the selection or cancel an incorrect entry, scan the *Cancel* bar code on [page 7-145](#).



Code 39 - Two Discrete Lengths

**Length Within Range** - This option limits decodes to only those Code 39 symbols within a specified range. For example, to decode Code 39 symbols containing between 4 and 12 characters, first scan **Code 39 Length Within Range**. Then scan **0, 4, 1** and **2** (single digit numbers must always be preceded by a leading zero). Numeric bar codes begin on [page 7-143](#). To change the selection or to cancel an incorrect entry, scan the *Cancel* bar code on [page 7-145](#).

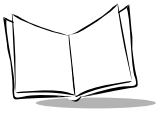


**Code 39 - Length Within Range**

**Any Length** - Scan this option to decode Code 39 symbols containing any number of characters.



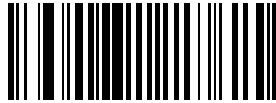
**Code 39 - Any Length**



## **Code 39 Check Digit Verification**

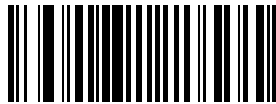
### **Parameter # 30h**

When this feature is enabled, the scanner checks the integrity of all Code 39 symbols to verify that the data complies with specified check digit algorithm. Only those Code 39 symbols which include a modulo 43 check digit are decoded.



**Enable Code 39 Check Digit**

**(01h)**



**\*Disable Code 39 Check Digit**

**(00h)**

## **Transmit Code 39 Check Digit**

### **Parameter # 2Bh**

Scan this symbol to transmit the check digit with the data.



**Transmit Code 39 Check Digit  
(Enable)**

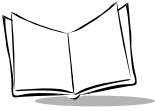
**(01h)**

Scan this symbol to transmit the data without the check digit.



**\*Do Not Transmit Code 39 Check Digit  
(Disable)**

**(00h)**



## **Enable/Disable Code 39 Full ASCII**

### **Parameter # 11h**

To enable or disable Code 39 Full ASCII, scan the appropriate bar code below.

When enabled, the ASCII character set assigns a code to letters, punctuation marks, numerals, and most control keystrokes on the keyboard.

The first 32 codes are non-printable and are assigned to keyboard control characters such as BACKSPACE and RETURN. The other 96 are called printable codes because all but SPACE and DELETE produce visible characters.

Code 39 Full ASCII interprets the bar code special character (\$ + % /) preceding a Code 39 character and assigns an ASCII character value to the pair. For example, when Code 39 Full ASCII is enabled and a **+B** is scanned, it is interpreted as **b**, **%J** as **?**, and **\$H** emulates the keystroke **BACKSPACE**. Scanning **ABC\$M** outputs the keystroke equivalent of **ABC ENTER**.

Do not enable Code 39 Full ASCII and Trioptic Code 39 simultaneously.

The scanner does not autodiscriminate between Code 39 and Code 39 Full ASCII.



**Enable Code 39 Full ASCII**

**(01h)**



**\*Disable Code 39 Full ASCII**

**(00h)**

## **Code 39 Decode Performance**

### **Parameter # 46h**

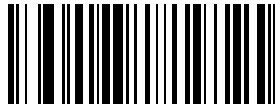
This option offers three levels of decode performance or “aggressiveness” for Code 39 symbols. Increasing the performance level reduces the amount of required bar code orientation, which is useful when scanning very long and/or truncated bar codes. Increased levels reduce decode security.

If you enable this option, you can select a Decode Performance level from the next page to suit performance needs.

---

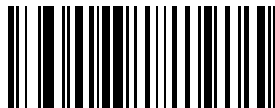
**Note:** *This option only works with Code 39 One Discrete Length.*

---



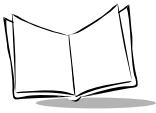
**\*Enable Code 39 Decode Performance**

**(01h)**



**Disable Code 39 Decode Performance**

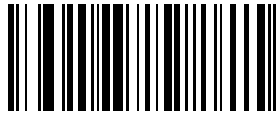
**(00h)**



## **Code 39 Decode Performance Level**

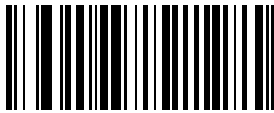
### **Parameter # 47h**

Select a level of decode performance.



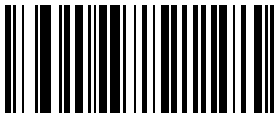
**Code 39 Decode Performance Level 1**

**(03h)**



**Code 39 Decode Performance Level 2**

**(02h)**



**\*Code 39 Decode Performance Level 3**

**(01h)**

## Code 93

---

### ***Enable/Disable Code 93***

#### ***Parameter # 09h***

To enable or disable Code 93, scan the appropriate bar code below.



**Enable Code 93**

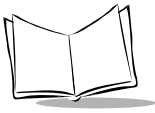
**(01h)**



**\*Disable Code 93**

**(00h)**





## Set Lengths for Code 93

### Parameter # L1 = 1Ah, L2 = 1Bh

The length of a code refers to the number of characters (i.e., human readable characters), including check digit(s) the code contains. Lengths for Code 93 can be set for any length, one or two discrete lengths, or lengths within a specific range.

**One Discrete Length** - Select this option to decode only those codes containing a selected length. For example, select **Code 93 One Discrete Length**, then scan **1, 4**, to limit decoding to only Code 93 symbols containing 14 characters. Numeric bar codes begin on [page 7-143](#). To change the selection or to cancel an incorrect entry, scan the **Cancel** bar code on [page 7-145](#).



Code 93 - One Discrete Length

**Two Discrete Lengths** - Select this option to decode only those codes containing two selected lengths. For example, select **Code 93 Two Discrete Lengths**, then scan **0, 2, 1, 4**, to limit the decoding to only Code 93 symbols containing 2 or 14 characters. Numeric bar codes begin on [page 7-143](#). To change the selection or to cancel an incorrect entry, scan the **Cancel** bar code on [page 7-145](#).



Code 93 - Two Discrete Lengths

**Length Within Range** - Select this option to decode only those codes within a specified range. For example, to decode Code 93 symbols containing between 4 and 12 characters, first scan **Code 93 Length Within Range**, then scan **0, 4, 1** and **2** (single digit numbers must always be preceded by a leading zero). Numeric bar codes begin on [page 7-143](#). To change the selection or to cancel an incorrect entry, scan the *Cancel* bar code on [page 7-145](#).

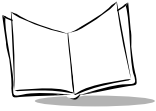


**Code 93 - Length Within Range**

**Any Length** - Scan this option to decode Code 93 symbols containing any number of characters.



**Code 93 - Any Length**



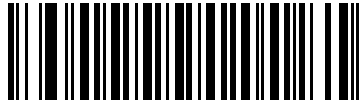
## Code 11

---

### ***Enable/Disable Code 11***

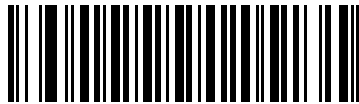
#### ***Parameter # 0Ah***

To enable or disable Code 11, scan the appropriate bar code below.



**Enable Code 11**

**(01h)**



**\*Disable Code 11**

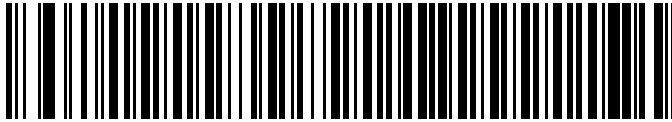
**(00h)**

## Set Lengths for Code 11

### Parameter # L1 = 1Ch, L2 = 1Dh

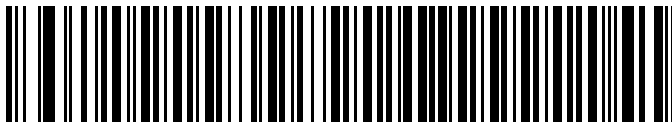
The length of a code refers to the number of characters (i.e., human readable characters), including check digit(s) the code contains. Lengths for Code 11 can be set for any length, one or two discrete lengths, or lengths within a specific range.

**One Discrete Length** - Select this option to decode only those codes containing a selected length. For example, select **Code 11 One Discrete Length**, then scan **1, 4**, to limit the decoding to only Code 11 symbols containing 14 characters. Numeric bar codes begin on [page 7-143](#). To change the selection or cancel an incorrect entry, scan the **Cancel** bar code on [page 7-145](#).

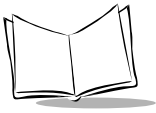


Code 11 - One Discrete Length

**Two Discrete Lengths** - Select this option to decode only those codes containing two selected lengths. For example, select **Code 11 Two Discrete Lengths**, then scan **0, 2, 1, 4**, to limit the decoding to only Code 11 symbols containing 2 or 14 characters. Numeric bar codes begin on [page 7-143](#). To change the selection or cancel an incorrect entry, scan the **Cancel** bar code on [page 7-145](#).



Code 11 - Two Discrete Lengths



**Length Within Range** - Select this option to decode only those codes within a specified range. For example, to decode Code 11 symbols containing between 4 and 12 characters, first scan **Code 11 Length Within Range**, then scan **0, 4, 1** and **2** (single digit numbers must always be preceded by a leading zero). Numeric bar codes begin on [page 7-143](#). To change the selection or cancel an incorrect entry, scan the *Cancel* bar code on [page 7-145](#).



**Code 11 - Length Within Range**

**Any Length** - Scan this option to decode Code 11 symbols containing any number of characters.

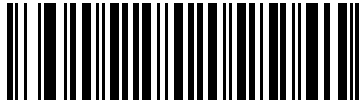


**Code 11 - Any Length**

## **Code 11 Check Digit Verification**

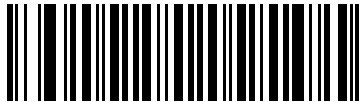
### **Parameter # 34h**

When enabled, this parameter checks the integrity of a Code 11 symbol to ensure it complies with a specified check digit algorithm. Select either to check for one check digit, check for two check digits, or to disable the feature.



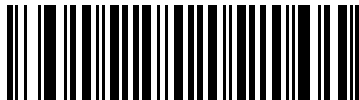
**\*Disable**

**(00h)**



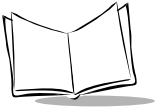
**One Check Digit**

**(01h)**



**Two Check Digits**

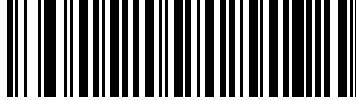
**(02h)**



## **Transmit Code 11 Check Digit**

### **Parameter # 2Fh**

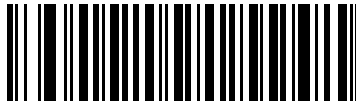
Scan this symbol to transmit the check digit with the data.



**Transmit Code 11 Check Digit  
(Enable)**

**(01h)**

Scan this symbol to transmit data without the check digit.



**\*Do Not Transmit Code 11 Check Digit  
(Disable)**

**(00h)**

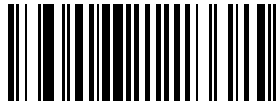
## Interleaved 2 of 5

---

### *Enable/Disable Interleaved 2 of 5*

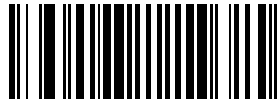
#### *Parameter # 06h*

To enable or disable Interleaved 2 of 5, scan the appropriate bar code below.



**Enable Interleaved 2 Of 5**

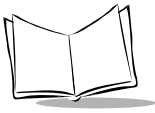
**(01h)**



**\*Disable Interleaved 2 Of 5**

**(00h)**





## Set Lengths for Interleaved 2 of 5

### Parameter # L1 = 16h, L2 = 17h

The length of a code refers to the number of characters (i.e., human readable characters) the code contains, and includes check digits. Lengths for I 2 of 5 can be set for any length, one or two discrete lengths, or lengths within a specific range.

**One Discrete Length** - Select this option to decode only those codes containing a selected length. For example, select **I 2 of 5 One Discrete Length**, then scan **1, 4**, to decode only I 2 of 5 symbols containing 14 characters. Numeric bar codes begin on [page 7-143](#). To change the selection or to cancel an incorrect entry, scan the *Cancel* bar code on [page 7-145](#).



I 2 of 5 - One Discrete Length

**Two Discrete Lengths** - Select this option to decode only those codes containing two selected lengths. For example, select **I 2 of 5 Two Discrete Lengths**, then scan **0, 2, 1, 4**, to decode only I 2 of 5 symbols containing 2 or 14 characters. Numeric bar codes begin on [page 7-143](#). To change the selection or to cancel an incorrect entry, scan the *Cancel* bar code on [page 7-145](#).



I 2 of 5 - Two Discrete Lengths

**Length Within Range** - Select this option to decode only codes within a specified range. For example, to decode I 2 of 5 symbols containing between 4 and 12 characters, first scan **I 2 of 5 Length Within Range**, then scan **0, 4, 1** and **2** (single digit numbers must always be preceded by a leading zero). Numeric bar codes begin on [page 7-143](#). To change the selection or to cancel an incorrect entry, scan the *Cancel* bar code on [page 7-145](#).



**I 2 of 5 - Length Within Range**

**Any Length** - Scan this option to decode I 2 of 5 symbols containing any number of characters.

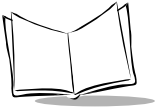
---

**Note:** *Selecting this option can lead to misdecodes for I 2 of 5 codes.*

---



**I 2 of 5 - Any Length**



## ***I 2 of 5 Check Digit Verification***

### ***Parameter # 31h***

When enabled, this parameter checks the integrity of an I 2 of 5 symbol to ensure it complies with a specified algorithm, either USS (Uniform Symbology Specification), or OPCC (Optical Product Code Council).



**\*Disable**

**(00h)**



**USS Check Digit**

**(01h)**



**OPCC Check Digit**

**(02h)**

## **Transmit I 2 of 5 Check Digit**

### **Parameter # 2Ch**

Scan this symbol to transmit the check digit with the data.



**Transmit I 2 of 5 Check Digit  
(Enable)**

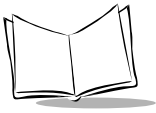
**(01h)**

Scan this symbol to transmit data without the check digit.



**\*Do Not Transmit I 2 of 5 Check Digit  
(Disable)**

**(00h)**



## **Convert I 2 of 5 to EAN-13**

### **Parameter # 52h**

This parameter converts a 14 character I 2 of 5 code into EAN-13, and transmits to the host as EAN-13. To accomplish this, the I 2 of 5 code must be enabled, one length must be set to 14, and the code must have a leading zero and a valid EAN-13 check digit.



**Convert I 2 of 5 to EAN-13  
(Enable)**

**(01h)**



**\*Do Not Convert I 2 of 5 to EAN-13  
(Disable)**

**(00h)**

## Discrete 2 of 5

---

### *Enable/Disable Discrete 2 of 5*

#### *Parameter # 05h*

To enable or disable Discrete 2 of 5, scan the appropriate bar code below.



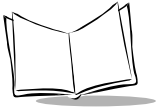
**Enable Discrete 2 Of 5**

**(01h)**



**\*Disable Discrete 2 Of 5**

**(00h)**



## Set Lengths for Discrete 2 of 5

### Parameter # L1 = 14h, L2 = 15h

The length of a code refers to the number of characters (i.e., human readable characters) the code contains, and includes check digits. Lengths for D 2 of 5 can be set for any length, one or two discrete lengths, or lengths within a specific range.

**One Discrete Length** - Select this option to decode only those codes containing a selected length. For example, select **D 2 of 5 One Discrete Length**, then scan **1, 4**, to decode only D 2 of 5 symbols containing 14 characters. Numeric bar codes begin on [page 7-143](#). To change the selection or to cancel an incorrect entry, scan the *Cancel* bar code on [page 7-145](#).



**D 2 of 5 - One Discrete Length**

**Two Discrete Lengths** - Select this option to decode only those codes containing two selected lengths. For example, select **D 2 of 5 Two Discrete Lengths**, then scan **0, 2, 1, 4**, to decode only D 2 of 5 symbols containing 2 or 14 characters. Numeric bar codes begin on [page 7-143](#). To change the selection or to cancel an incorrect entry, scan the *Cancel* bar code on [page 7-145](#).



**D 2 of 5 - Two Discrete Lengths**

**Length Within Range** - Select this option to decode codes within a specified range. For example, to decode D 2 of 5 symbols containing between 4 and 12 characters, first scan **D 2 of 5 Length Within Range**, then scan **0, 4, 1** and **2** (single digit numbers must be preceded by a leading zero). Numeric bar codes begin on [page 7-143](#). To change the selection or to cancel an incorrect entry, scan the *Cancel* bar code on [page 7-145](#).



**D 2 of 5 - Length Within Range**

**Any Length** - Scan this option to decode D 2 of 5 symbols containing any number of characters.

---

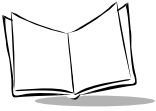
**Note:** *Selecting this option can lead to misdecodes of D 2 of 5 codes.*

---



**D 2 of 5 - Any Length**





## Codabar

---

### *Enable/Disable Codabar*

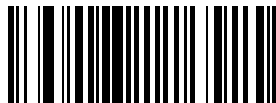
#### *Parameter # 07h*

To enable or disable Codabar, scan the appropriate bar code below.



**Enable Codabar**

**(01h)**



**\*Disable Codabar**

**(00h)**

## Set Lengths for Codabar

### Parameter # L1 = 18h, L2 = 19h

The length of a code refers to the number of characters (i.e., human readable characters) the code contains, including start or stop characters. Lengths for Codabar may be set for any length, one or two discrete lengths, or lengths within a specific range.

**One Discrete Length** - Select this option to decode only those codes containing a selected length. For example, select **Codabar One Discrete Length**, then scan **1, 4**, to decode only Codabar symbols containing 14 characters. Numeric bar codes begin on [page 7-143](#). To change the selection or to cancel an incorrect entry, scan the *Cancel* bar code on [page 7-145](#).

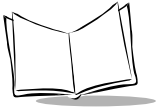


Codabar - One Discrete Length

**Two Discrete Lengths** - Select this option to decode only those codes containing two selected lengths. For example, select **Codabar Two Discrete Lengths**, then scan **0, 2, 1, 4**, to decode only Codabar symbols containing 2 or 14 characters. Numeric bar codes begin on [page 7-143](#). To change the selection or to cancel an incorrect entry, scan the *Cancel* bar code on [page 7-145](#).



Codabar - Two Discrete Lengths



**Length Within Range** - Select this option to decode a code within a specified range. For example, to decode Codabar symbols containing between 4 and 12 characters, first scan **Codabar Length Within Range**, then scan **0, 4, 1** and **2** (single digit numbers must always be preceded by a leading zero). Numeric bar codes begin on [page 7-143](#). To change the selection or to cancel an incorrect entry, scan the *Cancel* bar code on [page 7-145](#).



**Codabar - Length Within Range**

**Any Length** - Scan this option to decode Codabar symbols containing any number of characters.



**Codabar - Any Length**

## **CLSI Editing**

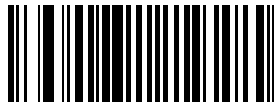
### **Parameter # 36h**

When enabled, this parameter strips the start and stop characters and inserts a space after the first, fifth, and tenth characters of a 14-character Codabar symbol.

---

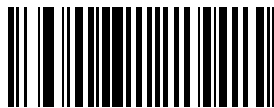
**Note:** *Symbol length does not include start and stop characters.*

---



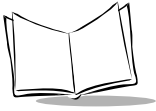
**Enable CLSI Editing**

**(01h)**



**\*Disable CLSI Editing**

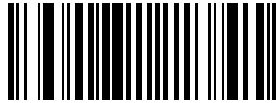
**(00h)**



## **NOTIS Editing**

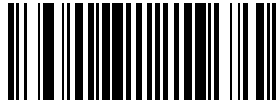
### **Parameter # 37h**

When enabled, this parameter strips the start and stop characters from decoded Codabar symbol.



**Enable NOTIS Editing**

**(01h)**



**\*Disable NOTIS Editing**

**(00h)**

## MSI Plessey

---

### *Enable/Disable MSI Plessey*

#### *Parameter # 0Bh*

To enable or disable MSI Plessey, scan the appropriate bar code below.



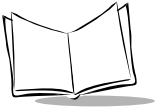
**Enable MSI Plessey**

**(01h)**



**\*Disable MSI Plessey**

**(00h)**



## Set Lengths for MSI Plessey

### Parameter # L1 = 1Eh, L2 = 1Fh

The length of a code refers to the number of characters (i.e., human readable characters) the code contains, and includes check digits. Lengths for MSI Plessey can be set for any length, one or two discrete lengths, or lengths within a specific range.

**One Discrete Length** - Select this option to decode only those codes containing a selected length. For example, select **MSI Plessey One Discrete Length**, then scan **1, 4**, to decode only MSI Plessey symbols containing 14 characters. Numeric bar codes begin on [page 7-143](#). To change the selection or to cancel an incorrect entry, scan the [Cancel](#) bar code on [page 7-145](#).



MSI Plessey - One Discrete Length

**Two Discrete Lengths** - Select this option to decode only those codes containing two selected lengths. For example, select **MSI Plessey Two Discrete Lengths**, then scan **0, 2, 1, 4**, to decode only MSI Plessey symbols containing 2 or 14 characters. Numeric bar codes begin on [page 7-143](#). To change the selection or to cancel an incorrect entry, scan the [Cancel](#) bar code on [page 7-145](#).



MSI Plessey - Two Discrete Lengths

**Length Within Range** - This option is used to decode codes within a specified range. For example, to decode MSI Plessey symbols containing between 4 and 12 characters, first scan **MSI Plessey Length Within Range**, then scan **0, 4, 1** and **2** (single digit numbers must always be preceded by a leading zero). Numeric bar codes begin on [page 7-143](#). To change the selection or to cancel an incorrect entry, scan the **Cancel** bar code on [page 7-145](#).



**MSI Plessey - Length Within Range**

**Any Length** - Scan this option to decode MSI Plessey symbols containing any number of characters.

---

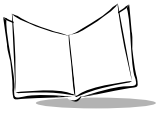
**Note:** *Selecting this option can cause misdecodes for MSI Plessey codes.*

---



**MSI Plessey - Any Length**





## **MSI Plessey Check Digits**

### **Parameter # 32h**

These check digits at the end of the bar code verify the integrity of the data. At least one check digit is required. Check digits are not automatically transmitted with the data.



**\*One MSI Plessey Check Digit**

**(00h)**

If two check digits is selected, also select an [MSI Plessey Check Digit Algorithm](#). See [page 7-94](#).



**Two MSI Plessey Check Digit**

**(01h)**

## ***Transmit MSI Plessey Check Digit***

### ***Parameter # 2Eh***

Scan this symbol to transmit the check digit with the data.



**Transmit MSI Plessey Check Digit  
(Enable)**

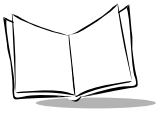
**(01h)**

Scan this symbol to transmit the data without the check digit.



**\*Do Not Transmit MSI Plessey Check Digit  
(Disable)**

**(00h)**



## **MSI Plessey Check Digit Algorithm**

### **Parameter # 33h**

When the Two MSI Plessey check digits option is selected, an additional verification is required to ensure integrity. Select one of the following algorithms.



**\*MOD 10/ MOD 11**

**(00h)**



**MOD 10/ MOD 10**

**(01h)**

## PDF417/MicroPDF417

---

### *Enable/Disable PDF417*

#### *Parameter # 0fh*

To enable or disable PDF417, scan the appropriate bar code below.



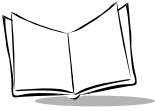
**Enable PDF417**

**(01h)**



**Disable PDF417**

**(00h)**



## **Enable/Disable MicroPDF417**

### **Parameter # E3h**

To enable or disable MicroPDF417, scan the appropriate bar code below.



**Enable MicroPDF417**

**(01h)**



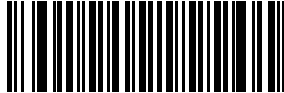
**\*Disable MicroPDF417**

**(00h)**

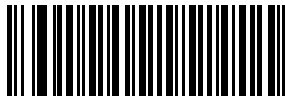
## **MicroPDF Performance**

### **Parameter # F0h 65h**

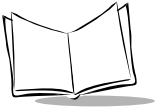
If the scanner is having trouble decoding MicroPDF symbols, select Selective Performance. Note that this can decrease decoding aggressiveness on some symbols.



**\*Standard Performance for MicroPDF**



**Selective Performance for MicroPDF**



## Code 128 Emulation

### Parameter # 7Bh

When this parameter is enabled, the scanner transmits data from certain MicroPDF417 symbols as if it was encoded in Code 128 symbols. Transmit AIM Symbology Identifiers must be enabled for this parameter to work.

If Code 128 Emulation is enabled, these MicroPDF417 symbols are transmitted with one of the following prefixes:

- JC1 if the first codeword is 903-907, 912, 914, 915
- JC2 if the first codeword is 908 or 909
- JC0 if the first codeword is 910 or 911

If disabled, they are transmitted with one of the following prefixes:

- JL3 if the first codeword is 903-907, 912, 914, 915
- JL4 if the first codeword is 908 or 909
- JL5 if the first codeword is 910 or 911

Scan a bar code below to enable or disable Code 128 Emulation.



**Enable Code 128 Emulation**

**(01h)**



**\*Disable Code 128 Emulation**

**(00h)**

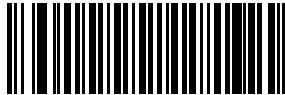
## RSS Codes

---

### ***RSS-14***

#### ***Parameter # F0h 52h***

To enable or disable RSS-14, scan the appropriate bar code below.

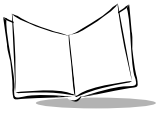


**Enable RSS-14  
(01h)**



**\*Disable RSS-14  
(00h)**

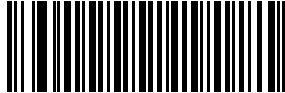




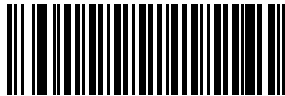
## **RSS-Limited**

### **Parameter # F0h 53h**

To enable or disable RSS-Limited, scan the appropriate bar code below.



**Enable RSS-Limited  
(01h)**

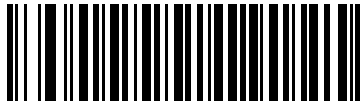


**\*Disable RSS-Limited  
(00h)**

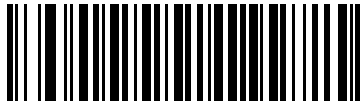
## ***RSS-Expanded***

### ***Parameter # F0h 54h***

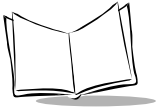
To enable or disable RSS-Expanded, scan the appropriate bar code below.



**Enable RSS-Expanded  
(01h)**



**\*Disable RSS-Expanded  
(00h)**



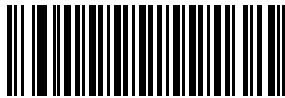
## Composite (MS-3204 Only)

---

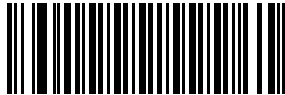
### Composite CC-C

#### Parameter # F0h 55h

Scan a bar code below to enable or disable Composite bar codes of type CC-C.



Enable CC-C  
(01h)



\*Disable CC-C  
(00h)

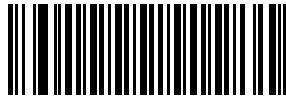
## **Composite CC-A/B**

### **Parameter # F0h 56h**

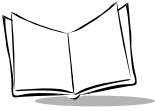
Scan a bar code below to enable or disable Composite bar codes of type CC-A/B.



**Enable CC-A/B  
(01h)**



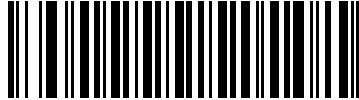
**\*Disable CC-A/B  
(00h)**



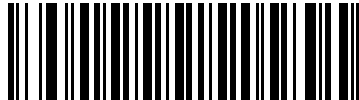
## **Composite TLC-39**

### **Parameter # F0h 73h**

Scan a bar code below to enable or disable Composite bar codes of type TLC-39.



**Enable TLC39  
(01h)**



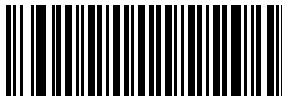
**\*Disable TLC39  
(00h)**

## **UPC Composite Mode**

### **Parameter # F0h 58h**

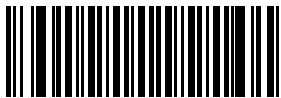
UPC symbols can be “linked” with a 2D symbol during transmission as if they were one symbol. Three options are offered for these symbols:

- Select **UPC Never Linked** to transmit UPC bar codes regardless of whether a 2D symbol is detected.
- Select **UPC Always Linked** to transmit UPC bar codes and the 2D portion. If 2D is not present, the UPC bar code does not transmit.
- If **Autodiscriminate UPC Composites** is selected, the scanner determines if there is a 2D portion, then transmits the UPC, as well as the 2D portion if present.



**UPC Never Linked**

(00h)



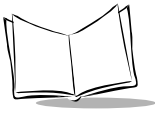
**\*UPC Always Linked**

(01h)



**Autodiscriminate UPC Composites**

(02h)



## Data Options

---

### **Transmit Code ID Character**

#### **Parameter # 2Dh**

A code ID character identifies the code type of a scanned bar code. This can be useful when decoding more than one code type. The code ID character is inserted between the prefix character (if selected) and the decoded symbol.

Select no code ID character, a Symbol Code ID character, or an AIM Code ID character. The Symbol Code ID characters are listed below.

**Table 7-2. Symbol Code ID Characters**

Code Type	Symbol Identifier
UPC-A, UPC-E, UPC-E1, EAN-13, EAN-8	A
Code 39, Code 32	B
Codabar	C
Code 128, ISBT 128	D
Code 93	E
Interleaved 2 of 5	F
Discrete 2 of 5, D 2of 5 IATA	G
Code 11	H
MSI Plessey	J
UCC/EAN 128	K
Bookland EAN	L
Trioptic Code 39	M
Coupon Code	N
RSS (all variants)	R
Composite*	T
Scanlet	W
PDF417, Micro PDF-417, Macro PDF-417, Micro MacroPDF-417	X

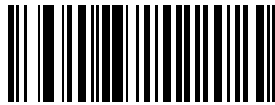
\*Note: UPC/EAN Composite is transmitted in two portions, each with a "T" prefix.

## ***Transmit Code ID Character (continued)***



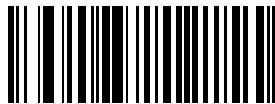
**Symbol Code ID Character**

**(02h)**



**AIM Code ID Character**

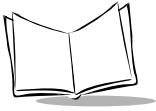
**(01h)**



**\*None**

**(00h)**





## **Prefix/Suffix Values**

### **Parameter # P = 69h, S1 = 68h, S2 = 6Ah**

A prefix and/or one or two suffixes may be appended to scan data for use in data editing. To set these values, first scan one of the following bar codes, then scan a four-digit number (i.e., four bar codes from [Numeric Bar Codes](#) beginning on [page 7-143](#)) that corresponds to key codes for various terminals. These codes can be found in [Table A-1 on page A-1](#).

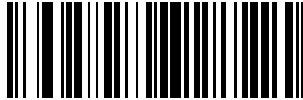
To change the selection or to cancel an incorrect entry, scan the [Cancel](#) bar code on [page 7-145](#).

---

**Note:** *In order to use Prefix/Suffix values, first set the [Scan Data Transmission Format \(MS-3204\)](#). See [page 7-110](#).*

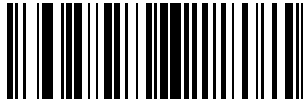
---

## ***Prefix/Suffix Values (continued)***



**Scan Prefix**

**(07h)**



**Scan Suffix 1**

**(06h)**

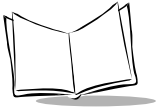


**Scan Suffix 2**

**(08h)**



**Data Format Cancel**



## Scan Data Transmission Format (MS-3204)

### Parameter # EBh

To change the Scan Data Transmission Format, scan one of the following eight bar codes corresponding to the desired format.



\*Data As Is

(00h)



<DATA> <SUFFIX 1>

(01h)



<DATA> <SUFFIX 2>

(02h)



<DATA> <SUFFIX 1> <SUFFIX 2>

(03h)

## Scan Data Transmission Format (MS-3204) (continued)



<PREFIX> <DATA >

(04h)



<PREFIX> <DATA> <SUFFIX 1>

(05h)



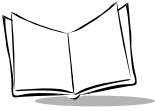
<PREFIX> <DATA> <SUFFIX 2>

(06h)



<PREFIX> <DATA> <SUFFIX 1> <SUFFIX 2>

(07h)



## Scan Data Transmission Format (MS-3207)

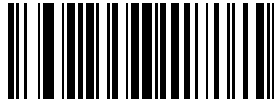
To change the Scan Data Transmission Format, scan the **Scan Options** bar code below, then select one of four options:

- Data As Is
- <DATA> <SUFFIX>
- <PREFIX> <DATA>
- <PREFIX> <DATA> <SUFFIX>

After making a selection, scan the **Enter** bar code on page [7-113](#). To change the selection or to cancel an incorrect entry, scan the **Data Format Cancel** bar code on page [7-113](#).

To add a carriage return/enter after each bar code scanned, scan the following bar codes in order:

1. <SCAN OPTIONS>
2. <DATA> <SUFFIX>
3. Enter (on page [7-113](#)).

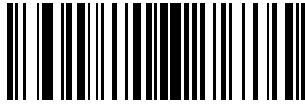


Scan Options

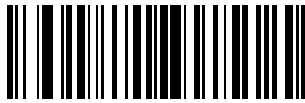


\*Data As Is

## Scan Data Transmission Format (MS-3207) (continued)



<DATA> <SUFFIX>



<PREFIX> <DATA>



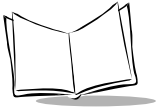
<PREFIX> <DATA> <SUFFIX>



Enter



Data Format Cancel



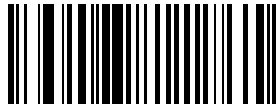
## Simple Serial Interface (SSI) Options (MS-3204 Only)

---

### **Baud Rate**

#### **Parameter # 9Ch**

Baud rate is the number of bits of data transmitted per second. The scanner's baud rate setting should match the data rate setting of the host device. If not, data may not reach the host device or may reach it in distorted form.



**Baud Rate 300**

(01h)



**Baud Rate 600**

(02h)



**Baud Rate 1200**

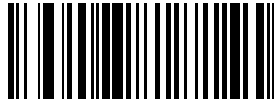
(03h)



**Baud Rate 2400**

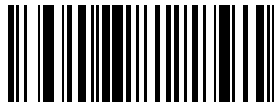
(04h)

## ***Baud Rate (continued)***



**Baud Rate 4800**

**(05h)**



**\*Baud Rate 9600**

**(06h)**



**Baud Rate 19,200**

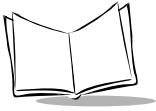
**(07h)**



**38,400**

**(08h)**



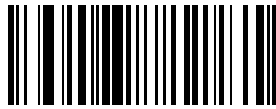


## Parity

### Parameter # 9Eh

A parity check bit is the most significant bit of each ASCII coded character. Select the parity type according to host device requirements.

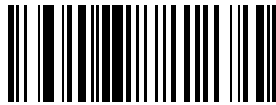
If you select **Odd** parity, the parity bit has a value 0 or 1, based on data, to ensure that an odd number of 1 bits is contained in the coded character.



**Odd**

**(00h)**

If you select **Even** parity, the parity bit has a value 0 or 1, based on data, to ensure that an even number of 1 bits is contained in the coded character.

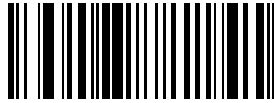


**Even**

**(01h)**

## ***Parity (continued)***

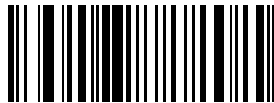
Select **Mark** parity and the parity bit is always 1.



**Mark**

**(02h)**

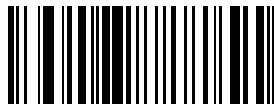
Select **Space** parity and the parity bit is always 0.



**Space**

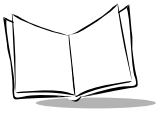
**(03h)**

If no parity is required, select **None**.



**\*None**

**(04h)**



## **Check Parity**

### **Parameter # 97h**

Select whether or not the parity of received characters is checked. Select the type of parity through the *Parity* parameter.



**\*Check Parity**

**(01h)**



**Do Not Check Parity**

**(00h)**

## **Software Handshaking**

### **Parameter # 9Fh**

This parameter offers control of the data transmission process in addition to that offered by hardware handshaking. Hardware handshaking is always enabled and cannot be disabled by the user.

#### **Disable ACK/NAK Handshaking**

When this option is selected, the decoder neither generates nor expects ACK/NAK handshaking packets.



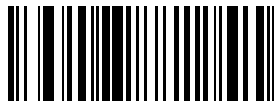
**Disable ACK/NAK**

**(00h)**

#### **Enable ACK/NAK Handshaking**

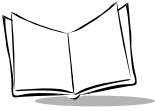
When this option is selected, after transmitting data, the scanner expects either an ACK or NAK response from the host. The scanner also ACKs or NAKs messages from the host.

The scanner waits up to the programmable Host Serial Response Time-out to receive an ACK or NAK. If the scanner does not get a response in this time, it resends its data up to two times before discarding the data and declaring a transmit error.



**\*Enable ACK/NAK**

**(01h)**



## Host RTS Line State

### Parameter # 9Ah

This parameter is used to set the idle state of the Serial Host RTS line.

The SSI Interface is intended to be used with host applications which also implement the SSI protocol. However, the scanner can be used in a "scan-and-transmit" mode to communicate with any standard serial communications software on a host PC (see [Decode Data Packet Format](#) on page 7-121). If transmission errors occur in this mode, the host PC may be asserting hardware handshaking lines which interfere with the SSI protocol. Scan the **HOST: RTS HIGH** bar code to address this problem.



**\*Host: RTS Low**

**(00h)**



**Host: RTS High**

**(01h)**

## ***Decode Data Packet Format***

### ***Parameter # EEh***

This parameter selects whether decoded data is transmitted in raw format (unpacketed), or transmitted with the packet format as defined by the serial protocol.

If the raw format is selected, ACK/NAK handshaking is disabled for decode data.



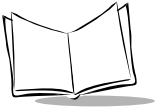
**\*Send Raw Decode Data**

**(00h)**



**Send Packeted Decode Data**

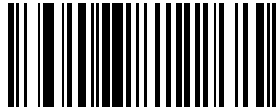
**(01h)**



## Stop Bit Select

### Parameter # 9Dh

The stop bit(s) at the end of each transmitted character marks the end of transmission of one character and prepares the receiving (host) device for the next character in the serial data stream. Set the number of stop bits (one or two) to match host device requirements.



**\*1 Stop Bit**

**(01h)**



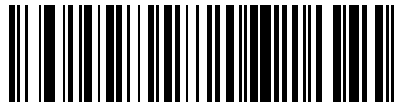
**2 Stop Bits**

**(02h)**

## ***Intercharacter Delay***

### ***Parameter # 6Eh***

The intercharacter delay gives the host system time to service its receiver and perform other tasks between characters. Select the intercharacter delay option matching host requirements. The delay period can range from no delay to 99 msec in 1 msec increments. After scanning the bar code below, scan two bar codes beginning on [page 7-143](#) to set the desired time-out. To change the selection or to cancel an incorrect entry, scan the *Cancel* bar code on [page 7-145](#).



**Intercharacter Delay**

## ***Host Serial Response Time-out***

### ***Parameter # 9Bh***

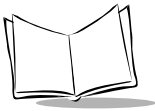
This parameter specifies how long the decoder waits for an ACK or NAK before resending. Also, if the decoder wants to send, and the host has already been granted permission to send, the decoder waits for the designated time-out before declaring an error.

The delay period can range from 0.0 to 9.9 seconds in 0.1 second increments. After scanning the bar code below, scan two numeric bar codes beginning on [page 7-143](#). Time durations of less than 1.0 second require a leading zero. To change the selection or to cancel an incorrect entry, scan the *Cancel* bar code on [page 7-145](#).



**Host Serial Response Time-out**





## Host Character Time-out

### Parameter # EFh

This parameter determines the maximum time the decoder waits between characters transmitted by the host before discarding the received data and declaring an error. The time-out is set in 0.01 second increments from 0.01 seconds to 0.99 seconds. After scanning the bar code below, scan two bar codes beginning on [page 7-143](#) to set the desired time-out. To change the selection or to cancel an incorrect entry, scan the [Cancel](#) bar code on [page 7-145](#).



Host Character Time-out

## Event Reporting

---

The host can request the decoder to provide certain information (events) relative to the decoder's behavior. Enable or disable the events listed in [Table 7-3](#) by scanning the appropriate bar codes on the following pages. Parameter number format for these parameters follows those shown in the *Simple Serial Interface (SSI) Programmer's Guide* for parameters numbered 256 or higher.

**Table 7-3. Event Codes**

Event Class	Event	Code Reported
<b>Decode Event</b>	Non parameter decode	01h
<b>Boot Up Event</b>	System power-up	03h
<b>Parameter Event</b>	Parameter entry error	07h
	Parameter stored	08h
	Defaults set (and parameter event is enabled by default)	0Ah
	Number expected	0Fh

## ***Decode Event***

### ***Parameter # F0h 00h***

When enabled, the scanner sends a message to the host whenever a bar code is successfully decoded. When disabled, no message is sent.



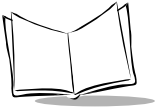
**Enable**

**(01h)**



**\*Disable**

**(00h)**



## **Boot Up Event**

### **Parameter # F0h 02h**

When enabled, the sends a message a message to the host whenever power is applied.  
When disabled, no message is sent.



**Enable**

**(01h)**



**\*Disable**

**(00h)**

## **Parameter Event**

### **Parameter # F0h 03h**

When enabled, the scanner sends a message to the host when one of the events specified in [Table 7-3 on page 7-124](#) occurs. When disabled, no message is sent.



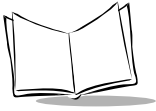
**Enable**

**(01h)**



**\*Disable**

**(00h)**



## Macro PDF Features

---

### ***Transmit Symbols in Codeword Format***

#### ***Parameter # Afh***

Enable this to transmit each PDF symbol as directly decoded data codewords, whether or not that symbol is part of a macro PDF sequence. Note that data is output as codeword values, not as interpreted data.

“Codeword values” is an ASCII representation of a number from 000 to 928 for each codeword, preceded by an escape character. This escape character is a backslash by default, but you can change this value. For example, the codeword value 005 is sent to the host in the form of \005 for GLIs, and \C005C for ECIs. This output format is based on the AIM USA Uniform Symbology Specification for PDF417 (1994).

All output codewords are exactly 4 characters for GLIs and 6 characters for ECIs. However, there can be non-decodable characters in the PDF symbol, such as a GLI sequence. This special codeword sequence activates a certain kind of interpretation to the encoded data. Non-decodable codewords like GLIs are embedded in the output stream like any other codeword, e.g., \927\001.

Because GLIs are indistinguishable from other codewords in the output data stream, the host must recognize them as GLIs and process their interpretations.

Note that when a macro PDF sequence is transmitted, the last character in the last block of data transmitted is always \922 (if selected). This indicates the end of that macro PDF transmission.

## ***Transmit Symbols in Codeword Format (Continued)***

Scan the appropriate bar code to enable or disable this.



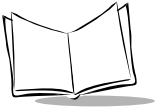
**Enable Transmit In Codeword Format**

**(01h)**



**\*Disable Transmit In Codeword Format**

**(00h)**



## **Transmit Unknown Codewords**

### **Parameter # BAh**

Select **Transmit Unknown Codewords** to use the output codeword format for transmitting any non-GLI or non-macro PDF codeword. Select **Do Not Transmit Unknown Codewords** to sound a decode error beep when an unknown codeword is found.



**Transmit Unknown Codewords**

**(01h)**



**\*Do Not Transmit Unknown Codewords**

**(00h)**

## **Escape Characters**

### **Parameter # E9h**

This enables the backslash (\) character as an Escape character for systems that can process transmissions containing special data sequences. Scan a bar code below to either format special data (e.g., GLI escapes, MacroPDF417 Control Block optional fields) according to the GLI (Global Label Identifier) protocol or the ECI (Extended Channel Interpretation) protocol, or to disable this parameter.



**ECI Protocol**

**(01h)**



**GLI Protocol**

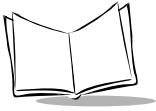
**(02h)**



**\*None**

**(00h)**





## **Delete Character Set ECIs**

### **Parameter # E6h**

Select **Delete Character Set ECIs** to delete any escape sequences representing Character Set ECIs (also known as GLIs) from its buffer before transmission. In many receiving systems, Character Set ECIs can be removed without affecting the way data is displayed or processed.

Select **Transmit Character Set ECIs** to transmit data from PDF417 and MicroPDF417 bar codes containing Character Set ECIs, even when the ECI Protocol is disabled.

Scan a bar code to delete or transmit character set ECIs.



**Delete Character Set ECIs**

**(01h)**



**\*Transmit Character Set ECIs**

**(00h)**

## **ECI Decoder**

### **Parameter # E8h**

This parameter enables the scanner to interpret any Extended Channel Interpretations (ECIs) that are supported by the scanner firmware. This does not affect symbols not encoded using ECIs. This version of the product supports ECIs 000900 through 000913, used for efficient encoding of Common Data Syntax Format 00-99. If this parameter is disabled, and a symbol is scanned that was encoded using an ECI escape, the scanner transmits the ECI escape followed by the uninterpreted data.

Scan a bar code to enable or disable this option.



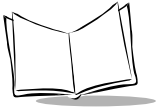
**\*Enable ECI Decoder**

**(01h)**



**Disable ECI Decoder**

**(00h)**



## Transmit Macro PDF User-Selected Fields

---

Enable or disable each of the following parameters to indicate whether or not to transmit the specified field in subsequently scanned Macro PDF417 symbols. The options cannot be changed in the middle of a Macro PDF set entry. All user-selected fields are prefixed by \923 for GLIs, and \C923C for ECIs. Tags and examples in the following parameters demonstrate GLI protocol, but the ECI tag (\C923C) can be used instead if ECI protocol is enabled.

### ***Transmit File Name***

#### ***Parameter # B0h***

Transmit File Name activates transmission of the file name field. The field character tag is \923\000. For example, the filename MANHOURS.WK1 is sent as:  
\923\000MANHOURS.WK1.



**Enable File Name Transmit**

**(01h)**



**\*Disable File Name Transmit**

**(00h)**

## ***Transmit Block Count***

### ***Parameter # B1h***

Transmit Block Count activates transmission of the block count field. The field character tag is \923\001. For example, the field may be: \923\0011856.



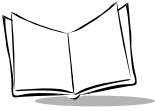
**Enable Transmit Block Count**

**(01h)**



**\*Disable Transmit Block Count**

**(00h)**



## **Transmit Time Stamp**

### **Parameter # B2h**

Transmit Time Stamp activates transmission of the time stamp field. The field character tag is \923\002. For example, the field may be: \923\0022123443243234.



**Enable Transmit Time Stamp**

**(01h)**



**\*Disable Transmit Time Stamp**

**(00h)**

## **Transmit Sender**

### **Parameter # B3h**

Transmit Sender activates transmission of the sender field. The field character tag is \923\003. For example, the field may be: \923\003Symbol Technologies Holtsville, NY.



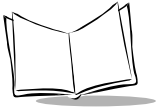
**Enable Sender Transmit**

**(01h)**



**\*Disable Sender Transmit**

**(00h)**



## **Transmit Addressee**

### **Parameter # B4h**

Transmit Addressee activates transmission of the addressee field. The field character tag is \923\004. For example, the field may be: \923\004AIM USA.



**Enable Addressee Transmit**

**(01h)**



**\*Disable Addressee Transmit**

**(00h)**

## **Transmit Checksum**

### **Parameter # B6h**

Transmit Checksum activates transmission of the checksum field. The field character tag is \923\006. For example, the field may be: \923\00663823.



**Enable Checksum Transmit**

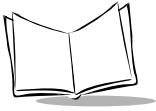
**(01h)**



**\*Disable Checksum Transmit**

**(00h)**





## **Transmit File Size**

### **Parameter # B5h**

Transmit File Size activates transmission of the file size field. The field character tag is \923\005. For example, the field may be: \923\005179234.



**Enable File Size Transmit**

**(01h)**



**\*Disable File Size Transmit**

**(00h)**

## **Transmit Macro PDF Control Header**

### **Parameter # B7h**

Transmit Macro PDF Control Header activates transmission of the control header, which contains the segment index and the file ID. For example, the field can be: \92800000\725\120\343. The five digits after the \928 are the segment index (or block index), and \725\120\343 is the file ID.



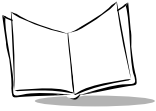
**Enable Macro PDF Control Header Transmit**

**(01h)**



**\*Disable Macro PDF Control Header Transmit**

**(00h)**



## **Last Blocker Marker**

### **Parameter # B9h**

**Enable Last Block Marker** marks the last block in the set by the codeword \922.



**Enable Last Block Marker**

**(01h)**



**\*Disable Last Block Marker**

**(00h)**

## Numeric Bar Codes

---

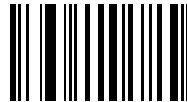
For parameters requiring specific numeric values, scan the appropriately numbered bar code(s).



0



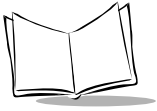
1



2



3



## Numeric Bar Codes (continued)

---



4



5



6



7

## Numeric Bar Codes (continued)

---



8



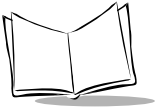
9

### ***Cancel***

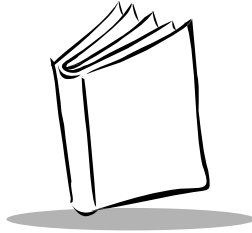
To change the selection or to cancel an incorrect entry, scan the bar code below.



**Cancel**



*MiniScan MS-320X Integration Guide*



## Chapter 8

### RS-232 Interface (MS-3207 Only)



## Introduction

---

This chapter provides RS-232 host information for setting up the MiniScan scanner, and only applies to the MS-3207. The RS-232 interface is used to attach the MiniScan scanner to point-of-sale devices, host computers, or other devices with an available RS-232 port (e.g., com port).

If your host is not listed in [Table 8-2](#), set the communication parameters to match the host device. Refer to the documentation for the host device.

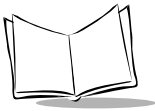
This scanner uses TTL RS-232 levels which interfaces with all PCs with no additional hardware.

---

**Note:** *Particularly noisy electrical environments may require a cable with an RS-232 transceiver. To obtain this cable contact the Symbol Support Center.*

---





Throughout the programming bar code menus, asterisks (\*) indicate default values.



\* Indicates Default — \* **Baud Rate 9600** — Feature/Option

## RS-232 Default Parameters

Table 8-1 lists the defaults for RS-232 host parameters. If you wish to change any option, scan the appropriate bar code(s) provided in the Parameter Descriptions section beginning on page 8-6.

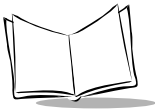
**Note:** See [Chapter 7, Parameter Menus](#) for all user preferences, hosts, symbologies, and miscellaneous default parameters.

**Table 8-1. RS-232 Host Default Table**

Parameter	Default	Page Number
<b>RS-232 Host Parameters</b>		
RS-232 Host Types	Standard <sup>1</sup>	8-6
Baud Rate	9600	8-9
Parity Type	None	8-11
Stop Bit Select	1 Stop Bit	8-12
Data Bits	8-Bit	8-12
Check Receive Errors	Enable	8-13
Hardware Handshaking	None	8-15
Software Handshaking	None	8-16
Host Serial Response Time-out	2 Sec	8-19
RTS Line State	Low RTS	8-20

**Table 8-1. RS-232 Host Default Table (Continued)**

<b>Parameter</b>	<b>Default</b>	<b>Page Number</b>
Beep on <BEL>	Disable	<a href="#">8-20</a>
Intercharacter Delay	0 msec	<a href="#">8-21</a>
Nixdorf Beep/LED Options	Normal Operation	<a href="#">8-22</a>
Ignore Unknown Characters	Send Bar Code	<a href="#">8-23</a>
<sup>1</sup> User selection is required to configure this interface and this is the most common selection.		



## RS-232 Host Parameters

Various RS-232 hosts are set up with their own parameter default settings (Table 8-2). Selecting the ICL, Fujitsu, Wincor-Nixdorf Mode A, Wincor-Nixdorf Mode B, Olivetti, Omron, or terminal sets the defaults listed below.

**Table 8-2. Terminal Specific RS-232**

Parameter	Standard (Default)	ICL	Fujitsu	Wincor-Nixdorf Mode A	Wincor-Nixdorf Mode B/ OPOS	Olivetti	Omron
<b>Transmit Code ID</b>	No	Yes	Yes	Yes	Yes	Yes	Yes
<b>Data Transmission Format</b>	Data as is	Data/Suffix	Data/Suffix	Data/Suffix	Data/Suffix	Prefix/Data/Suffix	Data/Suffix
<b>Suffix</b>	CR/LF (7013)	CR (1013)	CR (1013)	CR (1013)	CR (1013)	ETX (1002)	CR (1013)
<b>Baud Rate</b>	9600	9600	9600	9600	9600	9600	9600
<b>Parity</b>	None	Even	None	Odd	Odd	Even	None
<b>Hardware Handshaking</b>	None	RTS/CTS Option 3	None	RTS/CTS Option 3	RTS/CTS Option 3	None	None
<b>Software Handshaking</b>	None	None	None	None	None	Ack/Nak	None
<b>Serial Response Time-out</b>	2 Sec.	9.9 Sec.	2 Sec.	9.9 Sec.	9.9 Sec.	9.9 Sec.	9.9 Sec.
<b>Stop Bit Select</b>	One	One	One	One	One	One	One
<b>ASCII Format</b>	8-Bit	8-Bit	8-Bit	8-Bit	8-Bit	7-Bit	8-Bit
<b>Beep On &lt;BEL&gt;</b>	Disable	Disable	Disable	Disable	Disable	Disable	Disable
<b>RTS Line State</b>	Low	High	Low	Low	Low = No data to send	Low	High
<b>Prefix</b>	None	None	None	None	None	STX (1003)	None

\*In the Nixdorf Mode B, if CTS is Low, scanning is disabled. When CTS is High, the user can scan bar codes.

\*\*If Nixdorf Mode B is scanned without the scanner connected to the proper host, it may appear unable to scan. If this happens, scan a different RS-232 host type within 5 seconds of cycling power to the scanner.

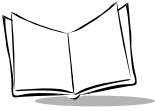


## RS-232 Host Parameters (continued)

Selecting the ICL, Fujitsu, Wincor-Nixdorf Mode A, Wincor-Nixdorf Mode B, OPOS terminal enables the transmission of code ID characters listed in [Table 8-3](#) below. These code ID characters are not programmable and are separate from the Transmit Code ID feature. Do not enable the Transmit Code ID feature for these terminals.

**Table 8-3. Terminal Specific Code ID Characters**

	ICL	Fujitsu	Wincor-Nixdorf Mode A	Wincor-Nixdorf Mode B/OPOS	Olivetti	Omron
<b>UPC-A</b>	A	A	A	A	A	A
<b>UPC-E</b>	E	E	C	C	C	E
<b>EAN-8/JAN-8</b>	FF	FF	B	B	B	FF
<b>EAN-13/JAN-13</b>	F	F	A	A	A	F
<b>Code 39</b>	C <len>	None	M	M	M <len>	C <len>
<b>Codabar</b>	N <len>	None	N	N	N <len>	N <len>
<b>Code 128</b>	L <len>	None	K	K	K <len>	L <len>
<b>I 2 of 5</b>	I <len>	None	I	I	I <len>	I <len>
<b>Code 93</b>	None	None	L	L	L <len>	None
<b>D 2 of 5</b>	H <len>	None	H	H	H <len>	H <len>
<b>UCC/EAN 128</b>	L <len>	None	P	P	P <len>	L <len>
<b>MSI</b>	None	None	O	O	O <len>	None
<b>Bookland EAN</b>	F	F	A	A	A	F
<b>Trioptic</b>	None	None	None	None	None	None
<b>Code 11</b>	None	None	None	None	None	None
<b>IATA</b>	H <len>	None	H	H	None	None
<b>Code 32</b>	None	None	None	None	None	None



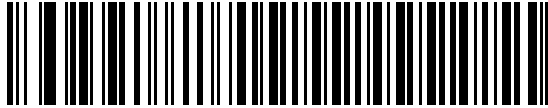
## RS-232 Host Types

To select an RS-232 host interface, scan one of the following bar codes.

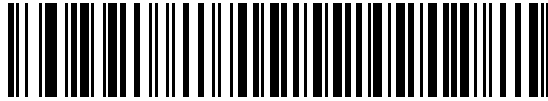
---

**Note:** *You must select an interface as there is no default; Standard RS-232 is the most common selection.*

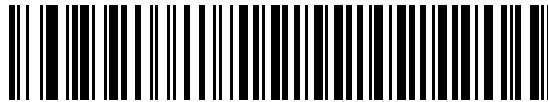
---



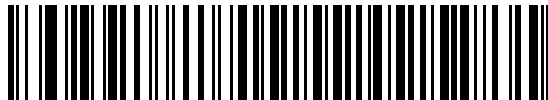
Standard RS-232<sup>1</sup>



ICL RS-232



Wincor-Nixdorf RS-232 Mode A



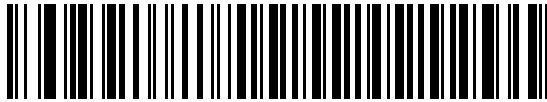
Wincor-Nixdorf RS-232 Mode B



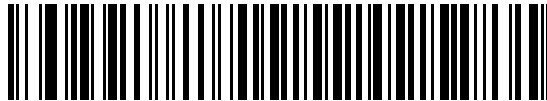
## ***RS-232 Host Types (continued)***



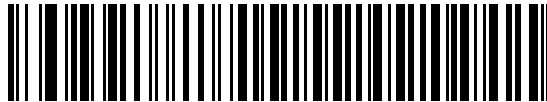
**Olivetti ORS450**



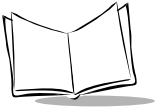
**Omron**



**OPOS/JPOS**



**Fujitsu RS-232**

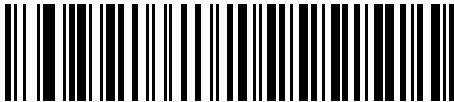


## **Baud Rate**

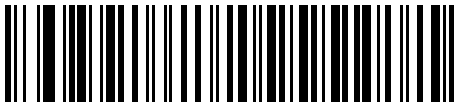
Baud rate is the number of bits of data transmitted per second. The scanner's baud rate setting should match the baud rate setting of the host device. If not, data may not reach the host device or may reach it in distorted form.



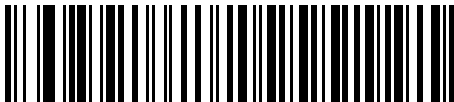
**Baud Rate 600**



**Baud Rate 1200**



**Baud Rate 2400**



**Baud Rate 4800**



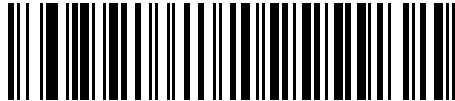
## ***Baud Rate (continued)***



**\*Baud Rate 9600**

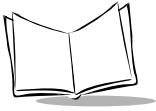


**Baud Rate 19,200**



**Baud Rate 38,400**





## Parity

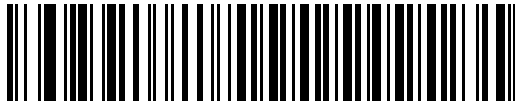
A parity check bit is the most significant bit of each ASCII coded character. Select the parity type according to host device requirements.

Select **Odd** parity and the parity bit value is set to 0 or 1, based on data, to ensure that an odd number of 1 bits are contained in the coded character.



Odd

Select **Even** parity and the parity bit value is set to 0 or 1, based on data, to ensure that an even number of 1 bits are contained in the coded character.



Even

Select **Mark** parity and the parity bit is always 1.



Mark



## ***Parity (continued)***

Select **Space** parity and the parity bit is always 0.

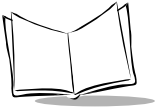


**Space**

Select **None** when no parity bit is required.



**\*None**



## Stop Bit Select

The stop bit(s) at the end of each transmitted character marks the end of transmission of one character and prepares the receiving device for the next character in the serial data stream. Select the number of stop bits (one or two) the host device is programmed to accommodate.



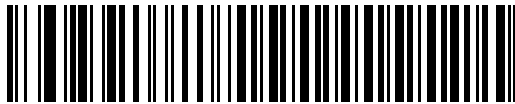
\*1 Stop Bit



2 Stop Bits

## Data Bits

This parameter allows the scanner to interface with devices requiring a 7-bit or 8-bit ASCII protocol.



7-Bit



\*8-Bit



## ***Check Receive Errors***

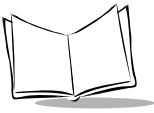
Select whether or not the parity, framing, and overrun of received characters are checked. The parity value of received characters is verified against the parity parameter selected above.



**\*Check For Received Errors**



**Do Not Check For Received Errors**



## Hardware Handshaking

The data interface consists of an RS-232 port designed to operate either with or without the hardware handshaking lines, *Request to Send (RTS)*, and *Clear to Send (CTS)*.

If Standard RTS/CTS handshaking is not selected, scan data is transmitted as it becomes available. Select Standard RTS/CTS handshaking to transmit scan data according to the following sequence:

- The scanner reads the CTS line for activity. If CTS is asserted, the scanner waits up to the Host Serial Response Time-out for the host to negate the CTS line. If, after the Host Serial Response Time-out (default), the CTS line is still asserted, the scanner sounds a transmit error and discards any scanned data.
- When the CTS line is negated, the scanner asserts the RTS line and waits up to the Host Serial Response Time-out for the host to assert CTS. When the host asserts CTS, the scanner transmits the data. If, after the Host Serial Response Time-out (default), the CTS line is not asserted, the scanner sounds a transmit error, and discards the data.
- When data transmission is complete, the scanner negates RTS 10 msec after sending the last character.
- The host responds by negating CTS. The scanner checks for a negated CTS upon the next transmission of data.

During data transmission, the CTS line should be asserted. If CTS is deasserted for more than 50 ms between characters, the transmission is aborted, the scanner sounds a transmission error, and the data is discarded.

If this communications sequence fails, the scanner issues an error indication. In this case, the data is lost and must be rescanned.

If Hardware Handshaking and Software Handshaking are both enabled, Hardware Handshaking takes precedence.

---

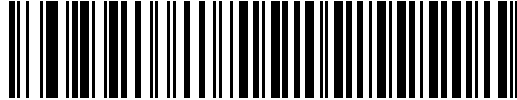
**Note:** *The DTR signal is jumpered to the active state.*

---



## None

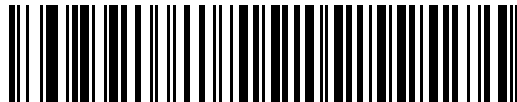
Scan the bar code below if no Hardware Handshaking is desired.



**\*None**

## Standard RTS/CTS

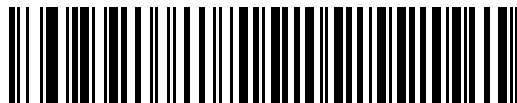
Scan the bar code below to select Standard RTS/CTS Hardware Handshaking.



**Standard RTS/CTS**

## RTS/CTS Option 1

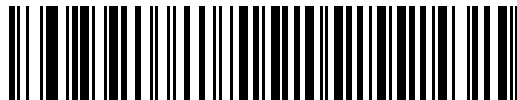
When RTS/CTS Option 1 is selected, the scanner asserts RTS before transmitting and ignores the state of CTS. The scanner de-asserts RTS when the transmission is complete.



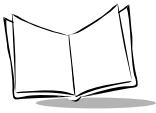
**RTS/CTS Option 1**

## RTS/CTS Option 2

When Option 2 is selected, RTS is always high or low (user-programmed logic level). However, the scanner waits for CTS to be asserted before transmitting data. If CTS is not asserted within Host Serial Response Time-out (default), the scanner issues an error indication and discards the data.

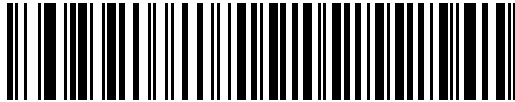


**RTS/CTS Option 2**



### **RTS/CTS Option 3**

When Option 3 is selected, the scanner asserts RTS prior to any data transmission, regardless of the state of CTS. The scanner waits up to Host Serial Response Time-out (default) for CTS to be asserted. If CTS is not asserted during this time, the scanner issues an error indication and discards the data. The scanner de-asserts RTS when transmission is complete.



**RTS/CTS Option 3**

### **Software Handshaking**

This parameter offers control of the data transmission process in addition to, or instead of, that offered by hardware handshaking. There are five options.

If Software Handshaking and Hardware Handshaking are both enabled, Hardware Handshaking takes precedence.

#### **None**

When this option is selected, data is transmitted immediately.



**\*None**



## ACK/NAK

When this option is selected, after transmitting data, the scanner expects either an ACK or NAK response from the host. When the scanner receives a NAK, it re-transmits the data and waits for either an ACK or NAK. After three unsuccessful attempts to send data, the scanner issues an error indication and discards the data.

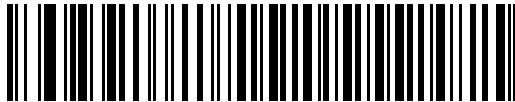
The scanner waits up to the programmable Host Serial Response Time-out to receive an ACK or NAK. If the scanner does not get a response in this time, it issues an error indication and discards the data. There are no retries when a time-out occurs.



ACK/NAK

## ENQ

When this option is selected, the scanner waits for an ENQ character from the host before transmitting data. If the scanner does not receive an ENQ within the Host Serial Response Time-out, it issues an error indication and discards the data. The host must transmit an ENQ character at least every Host Serial Response Time-out to prevent transmission errors.



ENQ

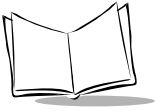
## ACK/NAK with ENQ

This combines the two previous options.



ACK/NAK with ENQ

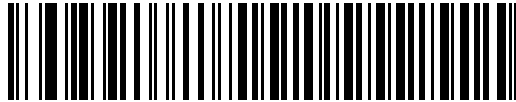




## **XON/XOFF**

An XOFF character turns the scanner transmission off until the scanner receives an XON character. There are two situations for XON/XOFF:

- XOFF is received before the scanner has data to send. When the scanner has data to send, it waits up to Host Serial Response Time-out for an XON character before transmission. If the scanner does not receive an XON within this time, it issues an error indication and discards the data.
- XOFF is received during a transmission. Data transmission then stops after sending the current byte. When the scanner receives an XON character, it sends the rest of the data message. The scanner waits indefinitely for the XON.



**XON/XOFF**

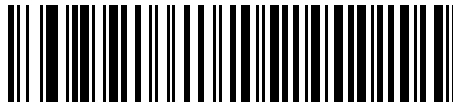


## ***Host Serial Response Time-out***

This parameter specifies how long the scanner waits for an ACK, NAK, or CTS before determining that a transmission error has occurred. This only applies when an ACK/NAK Software Handshaking mode or RTS/CTS Hardware Handshaking is enabled.



**\*Minimum: 2 Sec**



**Low: 2.5 Sec**



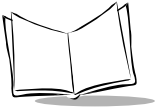
**Medium: 5 Sec**



**High: 7.5 Sec**



**Maximum: 9.9 Sec**

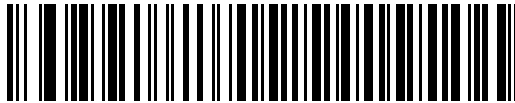


## **RTS Line State**

This parameter sets the idle state of the Serial Host RTS line. Scan a bar code below to select **Low RTS** or **High RTS** line state.



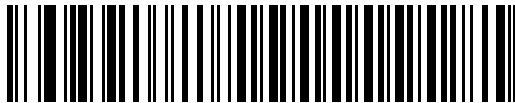
**\*Host: Low RTS**



**Host: High RTS**

## **Beep on <BEL>**

When this parameter is enabled, the scanner issues a beep when a <BEL> character is detected on the RS-232 serial line. <BEL> is issued to gain a user's attention to an illegal entry or other important event.



**Beep On <BEL> Character  
(Enable)**



**\*Do Not Beep On <BEL> Character  
(Disable)**



## ***Intercharacter Delay***

This parameter specifies the intercharacter delay inserted between character transmissions.



**\*Minimum: 0 msec**



**Low: 25 msec**



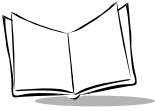
**Medium: 50 msec**



**High: 75 msec**

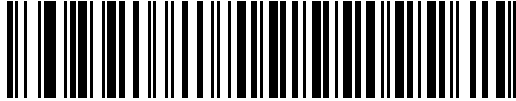


**Maximum: 99 msec**

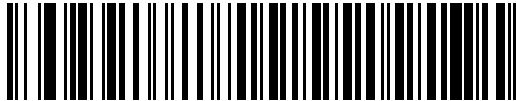


## **Nixdorf Beep/LED Options**

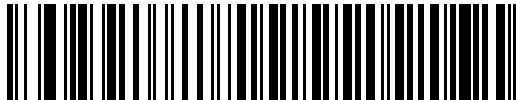
When Nixdorf Mode B is selected, this indicates when the scanner beeps and turns on its LED after a decode.



**\*Normal Operation**  
**(Beep/LED immediately after decode)**



**Beep/LED After Transmission**

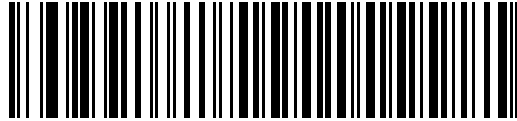


**Beep/LED After CTS Pulse**

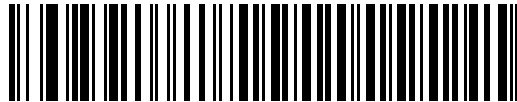


## ***Ignore Unknown Characters***

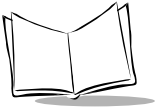
Unknown characters are characters the host does not recognize. When Send Bar Codes with Unknown Characters is selected, all bar code data is send except for unknown characters, and no error beeps sound on the scanner. When Do Not Send Bar Codes With Unknown Characters is selected, bar code data is sent up to the first unknown character and then four (error) beeps sound on the scanner.



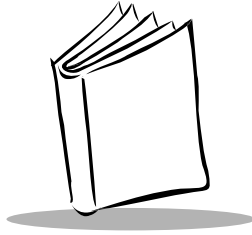
**\*Send Bar Code  
(with unknown characters)**



**Do Not Send Bar Codes  
(with unknown characters)**

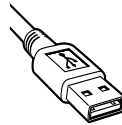


*MiniScan MS-320X Integration Guide*



## Chapter 9

# USB Interface (MS-3207 Only)



## Introduction

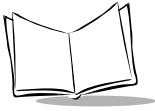
---

This chapter describes how to connect and configure the scanner with a USB host, and only applies to the MS-3207. The MiniScan scanner connects to and is powered by a USB host, or a powered USB hub. No additional power supply is required.

Throughout the programming bar code menus, asterisks (\*) indicated default values.







## **Connecting a USB Interface**

---

The scanner connects with USB capable hosts including:

- Desktop PCs and Notebooks
- Apple™ iMac, G4, iBooks (North America only)
- IBM SurePOS terminals
- Sun, IBM, and other network computers that support more than one keyboard.

The following operating systems support the scanner through USB:

- Windows 98, 2000, ME, XP
- MacOS 8.5 and above
- IBM 4690 OS.

The scanner also interfaces with other USB hosts that support USB Human Interface Devices (HID). For more information on USB technology, hosts, and peripheral devices, visit [www.symbol.com/usb](http://www.symbol.com/usb).



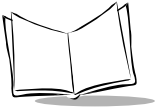
## USB Default Parameters

**Table 9-1** lists the defaults for USB host parameters. To change any option, scan the appropriate bar code(s) provided in *USB Host Parameters* on page 9-4.

**Note:** See *Chapter 7, Parameter Menus* for all user preferences, hosts, symbologies, and miscellaneous default parameters.

**Table 9-1. USB Host Default Table**

Parameter	Default	Page Number
USB Device Type	HID Keyboard Emulation	9-4
USB Country Keyboard Types (Country Codes)	North American	9-5
USB Keystroke Delay	No Delay	9-8
USB CAPS Lock Override	Disable	9-9
USB Ignore Unknown Characters	Enable	9-10
Emulate Keypad	Disable	9-11
USB FN1 Substitution	Disable	9-11
Function Key Mapping	Disable	9-12
Simulated Caps Lock	Disable	9-12
Convert Case	None	9-13



## USB Host Parameters

---

### *USB Device Type*

Select the desired USB device type.

---

**Note:** *When changing USB Device Types, the scanner automatically restarts and issues the standard startup beep sequences.*

---



**\*HID Keyboard Emulation**



**IBM Table Top USB**



**IBM Hand-Held USB**

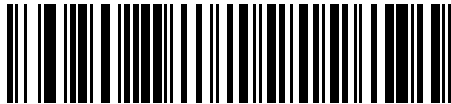


## ***USB Country Keyboard Types (Country Codes)***

Scan the bar code corresponding to your keyboard type. This setting applies only to the USB HID Keyboard Emulation device.



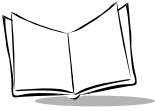
**\*North American Standard USB Keyboard**



**German Windows**



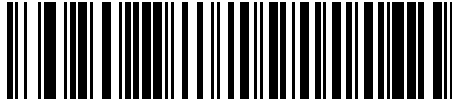
**French Windows**



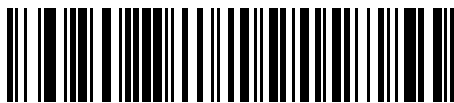
## ***USB Country Keyboard Types (continued)***



**French Canadian Windows 95/98**



**French Canadian Windows 2000/XP**



**Spanish Windows**



**Italian Windows**



## ***USB Country Keyboard Types (continued)***



**Swedish Windows**



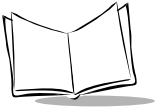
**UK English Windows**



**Japanese Windows (ASCII)**

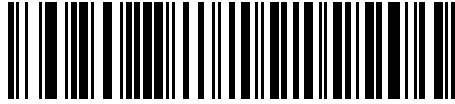


**Portuguese-Brazilian Windows**



## **USB Keystroke Delay**

This parameter sets the delay, in milliseconds, between emulated keystrokes. Scan a bar code below to increase the delay when hosts require a slower transmission of data.



**\*No Delay**



**Medium Delay (20 msec)**



**Long Delay (40 msec)**

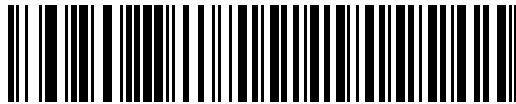


## **USB CAPS Lock Override**

This option applies only to the HID Keyboard Emulation device. When enabled, the case of the data is preserved regardless of the state of the caps lock key. This setting is always enabled for the *Japanese, Windows (ASCII)* keyboard type.

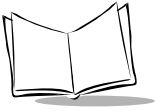


**Override Caps Lock Key  
(Enable)**



**\*Do Not Override Caps Lock Key  
(Disable)**



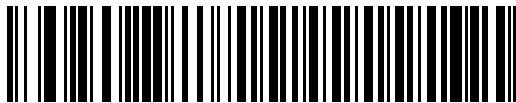


## **USB Ignore Unknown Characters**

This option applies only to the HID Keyboard Emulation device and IBM device. Unknown characters are characters the host does not recognize. Select **Send Bar Codes With Unknown Characters** to send all bar code data except for unknown characters. No error beeps sound. When **Do Not Send Bar Codes With Unknown Characters** is selected, bar codes containing at least one unknown character are not sent to the host, and an error beep sounds.



**\*Send Bar Codes With Unknown Characters  
(Transmit)**

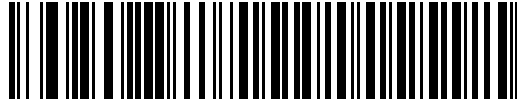


**Do Not Send Bar Codes with Unknown Characters  
(Disable)**

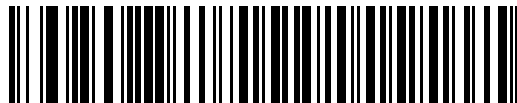


## ***Emulate Keypad***

When enabled, all characters are sent as ASCII sequences over the numeric keypad. For example ASCII A would be sent as “ALT make” 0 6 5 “ALT Break”.



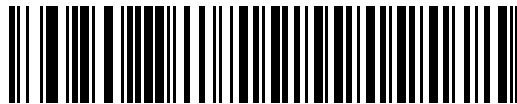
**\*Disable Keypad Emulation**



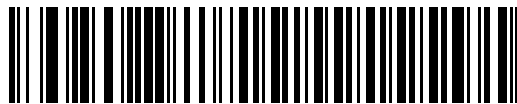
**Enable Keypad Emulation**

## ***USB Keyboard FN 1 Substitution***

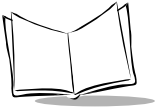
This option applies only to the USB HID Keyboard Emulation device. Enable this to replace any FN 1 characters in an EAN 128 bar code with a Key Category and value.



**Enable**

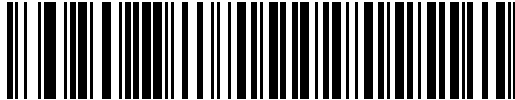


**\*Disable**

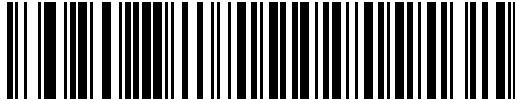


## **Function Key Mapping**

ASCII values under 32 are normally sent as a control-key sequences (see Table A-2 on page A-7). When this parameter is enabled, the keys in bold are sent in place of the standard key mapping. Table entries that do not have a bold entry remain the same whether or not this parameter is enabled.



**\*Disable Function Key Mapping**



**Enable Function Key Mapping**

## **Simulated Caps Lock**

When enabled, the scanner inverts upper and lower case characters on the scanner bar code as if the Caps Lock state is enabled on the keyboard. This is done regardless of the current state of the keyboard's Caps Lock state.



**\*Disable Simulated Caps Lock**



**Enable Simulated Caps Lock**



## **Convert Case**

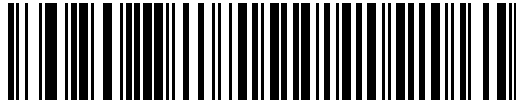
When enabled, the scanner will convert all bar code data to the selected case.



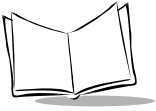
**\*No Case Conversion**



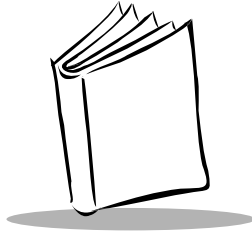
**Convert All to Upper Case**



**Convert All to Lower Case**



*MiniScan MS-320X Integration Guide*



## *Chapter 10*

### *123Scan (MS-3207 Only)*

#### **Introduction**

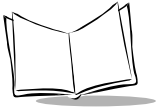
---

123Scan is a Windows®-based utility for the MS-3207 only, that enables programming these scanners with all parameters, including Advanced Data Formatting (ADF) rules. An ADF rule modifies bar code data before it is sent to the host to ensure compatibility between this data and the host application, so there is no need to modify the host software. Scanners can be programmed via PC download or by scanning a sheet of bar codes generated by the 123Scan utility. This programming information is saved in a file that can be distributed electronically. The 123Scan program includes a help file.

#### **Communication With the 123Scan PC Based Configuration Tool**

---

To communicate with the 123Scan program, which runs on a PC with Windows, use an RS-232 cable to connect the scanner to the PC.



## 123Scan Parameter

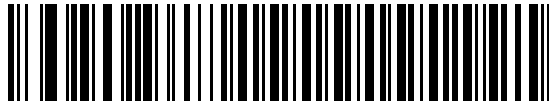
---

To communicate with the 123Scan program, install 123Scan, included in the documentation CD-ROM, onto the PC and scan the bar code below. Refer to 123Scan instructions for programming the scanner.

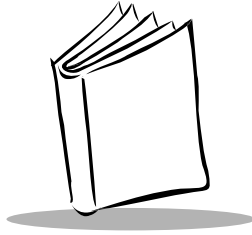
---

**Note:** *Scanning this bar code enables the 123Scan interface on the scanner.*

---



**123Scan Configuration**



# Chapter 11

## Advanced Data Formatting (MS-3207 Only)

### Introduction

---

Advanced Data Formatting (ADF) is a means of customizing data before transmission to a host device. Scan data can be edited to suit particular requirements.

ADF can be implemented through scanning a related series of bar codes, which begin on page 11-8, or by installing the 123Scan utility (see [Chapter 10, 123Scan \(MS-3207 Only\)](#)) which allows the MiniScan scanner to be programmed with Advanced Data Formatting (ADF) Rules.

### Rules: Criteria Linked to Actions

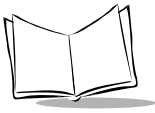
---

In ADF, data is customized through **rules**. These rules perform detailed actions when the data meets certain criteria. One rule may consist of single or multiple criteria applied to single or multiple actions.

For instance, a data formatting rule can be:

- Criteria:**            *When scan data is Code 39, length 12, and data at the start position is the string "129",*
- Actions:**            *pad all sends with zeros to length 8,  
send all data up to X,  
send a space.*





If a Code 39 bar code of 1299X1559828 is scanned, the scanner transmits:  
00001299<space>.

If a Code 39 bar code of 1299X15598 is scanned, this rule is ignored because the length criteria is not met.

The rule specifies the editing conditions and requirements before data transmission occurs.

## Using ADF Bar Codes

---

When programming a rule, make sure the rule is logically correct. Plan ahead before scanning.

To program each data formatting rule:

- **Start the Rule.** Scan the **Begin New Rule** bar code on page 11-8.
- **Criteria.** Scan the bar codes for all pertinent criteria. Criteria can include code type (e.g., Code 128), code length, or data that contains a specific character string (e.g., the digits “129”). These options are described in *Criteria* on page 11-12.
- **Actions.** Scan all actions related to, or affecting, these criteria. The actions of a rule specify how to format the data for transmission. These options are described in *ADF Bar Code Menu Example* on page 11-3.
- **Save the Rule.** Scan the **Save Rule** bar code on page 11-9. This places the rule in the “top” position in the rule buffer.
- If you make errors during this process, some special-purpose bar codes can be useful: **Erase Criteria and Start Again**, **Erase Actions and Start Again**, **Erase Previously Saved Rule**, etc.

Erase criteria, actions, and entire rules by scanning the appropriate bar code (see page 11-9).

*Beeper and LED Definitions* on page 1-8 help guide you through the programming steps.

## ADF Bar Code Menu Example

---

This section provides an example of how to enter and use ADF rules for scan data.

An auto parts distribution center wants to encode manufacturer ID, part number, and destination code into their own Code 128 bar codes. The distribution center also has products that carry UPC bar codes applied by the manufacturer. The Code 128 bar codes are in the format:

### **MMMMMPPPPDD**

Where:     M = Manufacturer ID  
           P = Part Number  
           D = Destination Code

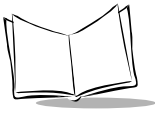
The distribution center uses a PC with dedicated control characters for manufacturer ID <CTRL M>, part number <CTRL P>, and destination code <CTRL D>. At this center the UPC data is treated as a manufacturer ID code.

The following rules need to be entered:

When scanning data of code type Code 128, send the next 5 characters, send the manufacturer ID key <CTRL M>, send the next 5 characters, send the part number key <CTRL P>, send the next 2 characters, send the destination code key <CTRL D>.

When scanning data of code type UPC/EAN, send all data, send the manufacturer ID key <CTRL M>.

To enter these rules, use the following steps:



## Rule 1: The Code 128 Scanning Rule

Step	Bar Code	On Page	Beep Indication
1	Begin New Rule	11-8	High High
2	Code 128	11-12	High High
3	Send next 5 characters	11-25	High High
4	Send <CTRL M>	11-45	High High
5	Send next 5 characters	11-25	High High
6	Send <CTRL P>	11-46	High High
7	Send next 2 characters	11-25	High High
8	Send <CTRL D>	11-44	High High
9	Save Rule	11-9	High Low High Low

## Rule 2: The UPC Scanning Rule

Step	Bar Code	On Page	Beep Indication
1	Begin New Rule	11-8	High High
2	UPC/EAN	11-13	High High
3	Send all remaining data	11-25	High High
4	Send <CTRL M>	11-45	High High
5	Save Rule	11-9	High Low High Low

If you make a mistake while entering this rule, scan the [Quit Entering Rules](#) bar code on page 11-10. If you already saved the rule, scan the [Erase Previously Saved Rule](#) bar code on page 11-9.

## Alternate Rule Sets

ADF rules can be grouped into one of four alternate sets which can be turned on and off when needed. This is useful to format the same message in different ways. For example, a Code 128 bar code contains the following information:

**Class (2 digits), Stock Number (8) digits, Price (5 digits)**

This bar code might look like:

**245671243701500**

where:

**Class = 24**

**Stock Number = 56712437**

**Price = 01500**

Ordinarily you would send this data as follows:

**24 (class key)**

**56712437 (stock key)**

**01500 (enter key)**

But, when there is a sale, you may want to send only the following:

**24 (class key)**

**56712437 (stock key)**

and the cashier keys the price manually.

To implement this, first enter an ADF rule that applies to the normal situation, such as:

**When scanning a bar code of length 15, send the next 2 characters, send the class key, send the next 8 characters, send the stock key, send the data that remains, send the Enter key.**

Then enter the “sale” rule, such as:

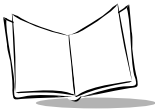
**When scanning a bar code of length 15, send the next 2 characters, send the class key, send the next 8 characters, send the stock key.**

To switch between the two sets of rules, program a “switching” rule that specifies what type of bar code must be scanned to switch between the rule sets. For example, in the case of the “sale” rule, the rule programmer wants the cashier to scan the bar code “M” before a sale. To do this, a rule can be entered as follows:

**When scanning a bar code of length 1 that begins with “M”, select rule set number 1.**

Another rule could be programmed to switch back:

**When scanning a bar code of length 1 that begins with “N”, turn off rule set number 1.**



The switching back to normal rules can also be done in the “sale” rule. For example:

**When scanning a bar code of length 15, send the next 2 characters, send the class key, send the next 8 characters, send the stock key, turn off rule set 1.**

It is recommended that you scan the **Disable All Rule Sets** bar code on page 11-11 after programming a rule belonging to an alternate rule set.

In addition to enabling and disabling rule sets within the rules, you can enable or disable them by scanning the appropriate bar codes on 11-11.

## ***Rules Hierarchy (in Bar Codes)***

The order of programming individual rules is important. Program the most general rule last.

All programmed rules are stored in a buffer. As they are programmed, they are stored at the “top” of a rules list. If three rules are created, the list is configured as follows:

**Third Rule**

**Second Rule**

**First Rule**

When data is scanned, the rules list is checked from top to bottom to determine if the criteria matches (and therefore, if the actions occur). Input is modified into the data format specified by the first matching set of criteria it finds. Program the most general rule last.

For example, if the THIRD rule states:

**When scanning a bar code of any length, send all data, then send the ENTER key.**

and the SECOND rule states:

**When scanning a Code 128 bar code of length 12, send the first four characters, then send the ENTER key, then send all remaining data.**

and a Code 128 bar code of length 12 is scanned, the THIRD rule takes effect and the SECOND rule appears to not function.

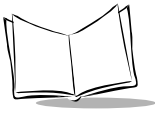
Note that ADF rules are also created when using the standard data editing functions. Scan options and prefix/suffix programming in the parameter *Scan Data Transmission Format* are entered as ADF rules. The hierarchy mentioned above also applies to them. These rules reside in the same “rule list” as ADF Rules, so the order of their creation is also important.

## ***Default Rules***

Every unit has a default rule to send all scan data. Units with custom software can have one or more default rules. The rules hierarchy checks user programmable rules first, then the default rules. To disable default rules, enter the following general rule in the user programmable buffer:

**When receiving scan data, send all data.**

Since this rule always applies, ADF never goes into the default rules.



## Special Commands

---

### ***Pause Duration***

This parameter along with [Send Pause](#) on page 11-29 inserts a pause in the data transmission. To set a pause, which is measured in 0.1 second intervals, scan a two-digit number (i.e., two numeric bar codes). For example, scanning bar codes **0** and **1** inserts a 0.1 second pause; **0** and **5** inserts a 0.5 second delay. Numeric bar codes begin on page [7-143](#). To change the selection or to cancel an incorrect entry, scan **Cancel** on page [7-145](#).



**Pause Duration**

### ***Begin New Rule***

Scan this bar code to start entering a new rule.



**Begin New Rule**

## ***Save Rule***

Scan this bar code to save the entered rule.



**Save Rule**

## ***Erase***

Use these bar codes to erase criteria, actions, or rules.



**Erase Criteria And  
Start Again**



**Erase Actions And  
Start Again**

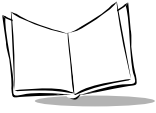


**Erase Previously  
Saved Rule**



**Erase All Rules**





## **Quit Entering Rules**

Scan this bar code to quit entering rules.



**Quit Entering Rules**

## ***Disable Rule Set***

Use these bar codes to disable rule sets.



**Disable Rule Set 1**



**Disable Rule Set 2**



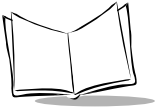
**Disable Rule Set 3**



**Disable Rule Set 4**



**Disable All Rule Sets**



## Criteria

---

### Code Types

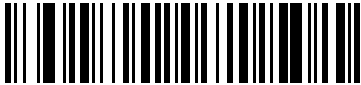
Select any number of code types to be affected. Scan all selected codes in succession, prior to selecting other criteria. *If you don't select a code type, all code types are affected.*



Code 39



Codabar



RSS 14



RSS Limited



RSS Expanded



Code 128

Scan the bar codes for all code types desired before selecting other criteria.



**D 2 OF 5**



**IATA 2 OF 5**



**I 2 OF 5**



**Code 93**



**UPC-A**



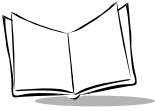
**UPC-E**



**EAN-8**



**EAN-13**



## **Code Types (continued)**



**MSI**



**UCC/EAN 128**



**UPC-E1**



**Bookland EAN**



**Trioptic Code 39**



**PDF417**

## Code Lengths

Scan these bar codes to define the number of characters the selected code type must contain. *If you don't select a code length, selected code types of any length are affected.*

Select one length per rule only.



**1 Character**



**2 Characters**



**3 Characters**



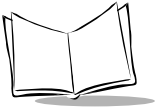
**4 Characters**



**5 Characters**



**6 Characters**



## Code Lengths (continued)



7 Characters



8 Characters



9 Characters



10 Characters



11 Characters



12 Characters

## Code Lengths (continued)



**13 Characters**



**14 Characters**



**15 Characters**



**16 Characters**

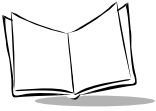


**17 Characters**



**18 Characters**





## Code Lengths (continued)



19 Characters



20 Characters



21 Characters



22 Characters



23 Characters



24 Characters

## Code Lengths (continued)



25 Characters



26 Characters



27 Characters



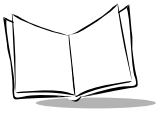
28 Characters



29 Characters



30 Characters



## Message Containing A Specific Data String

Use this feature to select whether the formatting affects data that begins with a specific character or data string, or contains a specific character or data string.

There are 4 features:

- Specific String at Start
- Specific String, Any Location
- Any Message OK
- Rule Belongs to Set

### Specific String at Start

To enter the desired character or characters:

1. Scan the following bar code.
2. Enter a string of characters (up to a total of 8) using the [Alphanumeric Keyboard](#) beginning on page 11-82.
3. Scan [End Of Message](#) on page 11-88.



**Specific String At Start**

## Specific String, Any Location

To enter the *position* (use a leading “zero” if necessary):

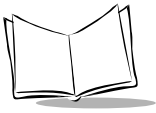
1. Scan the following bar code.
2. Enter a location using the [Numeric Keypad](#) on page 11-22.
3. Enter a string of characters (up to a total of 8) using the [Alphanumeric Keyboard](#) on page 11-82.
4. Scan the [End Of Message](#) bar code on page 11-88.



**Specific String Any Location**

## Any Message OK

Do not scan a bar code to format all selected code types, regardless of information contained.



## Numeric Keypad

Do not confuse these bar codes with those on the alphanumeric keyboard.



0



1



2



3



4



5



6



7



8



9



Cancel

## Rule Belongs To Set

Scan a bar code below to select the set a rule belongs to. There are four possible rule sets. Refer to [Alternate Rule Sets](#) on page 11-4 for more information.



**Rule Belongs To Set 1**



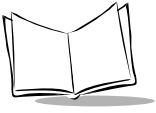
**Rule Belongs To Set 2**



**Rule Belongs To Set 3**



**Rule Belongs To Set 4**



## **Actions**

---

Select how to format the data for transmission.

## Send Data

Scan the following bar codes to send all data that remains, send all data up to a specific character selected from the *Alphanumeric Keyboard* on page 11-82, or send the next N characters. N = any number from 1 to 254, selected from the *Alphanumeric Keyboard*.



Send Data Up To  
Character



Send All Data That Re-  
mains



Send Next Character



Send Next  
2 Characters



Send Next  
3 Characters



Send Next  
4 Characters



Send Next  
5 Characters

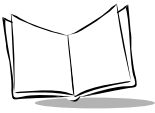


Send Next  
6 Characters



Send Next  
7 Characters





## Send Data (continued)



**Send Next  
8  
Characters**



**Send Next  
9  
Characters**



**Send Next  
10  
Characters**



**Send Next  
11  
Characters**



**Send Next  
12  
Characters**



**Send Next  
13  
Characters**



**Send Next  
14  
Characters**



**Send Next  
15  
Characters**



**Send Next  
16  
Characters**



**Send Next  
17  
Characters**

***Send Data (continued)***



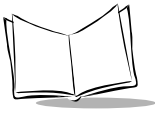
**Send Next  
18 Characters**



**Send Next  
19 Characters**



**Send Next  
20 Characters**



## Setup Field(s)

Table 11-1. Setup Field(s) Definitions

Parameter	Description	Page
<b>Move Cursor</b>		
<b>Move Cursor To a Character</b>	Scan the <b>Move Cursor To Character</b> bar code on page 11-29, then any printable ASCII character from the <i>Alphanumeric Keyboard</i> . When this is used, the cursor moves to the position after the matching character. If the character is not there, the rule fails and ADF tries the next rule.	11-29
<b>Move Cursor to Start of Data</b>	Scan this bar code to move cursor to the beginning of the data.	11-29
<b>Move Cursor Past a Character</b>	This parameter moves the cursor past all sequential occurrences of a selected character. For example, if the selected character is 'A', then the cursor moves past 'A', 'AA', 'AAA', etc. Scan the <b>Move Cursor Past Character</b> bar code on page 11-29, then select a character from the <i>Alphanumeric Keyboard</i> . If the character is not there, the cursor does not move (i.e., has no effect).	11-29
<b>Skip Ahead "N" Characters</b>	Scan one of these bar codes to select the number of positions ahead to move the cursor.	11-30
<b>Skip Back "N" Characters</b>	Scan one of these bar codes to select the number of positions back to move the cursor.	11-31
<b>Send Preset Value</b>	Send Values 1 through 6 by scanning the appropriate bar code from <i>Prefix/Suffix Values</i> on page 7-108. These values must be set using the prefix/suffix values in <a href="#">Table A-1 on page A-1</a> and <a href="#">Table A-2 on page A-7</a> .  Value 2 = Scan Prefix Value 1 = Scan Suffix 1 Value 3 = Scan Suffix 2	11-32

## Move Cursor

Scan a bar code below to move the cursor in relation to a specified character. Then enter a character by scanning a bar code from the [Alphanumeric Keyboard](#) beginning on page 11-82.

---

**Note:** *If there is no match when the rule is interpreted and the rule fails, the next rule is checked.*

---



**Move Cursor To  
Character**



**Move Cursor To Start**



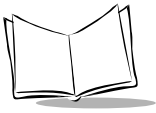
**Move Cursor Past  
Character**

## Send Pause

Scan the bar code below to insert a pause in the transmission of data. The length of this pause is controlled by the value of the Pause Duration parameter.

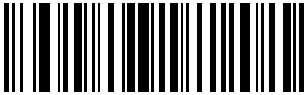


**Send Pause**



## Skip Ahead

Use the following bar codes to skip ahead characters.



**Skip Ahead  
1 Character**



**Skip Ahead  
2 Characters**



**Skip Ahead  
3 Characters**



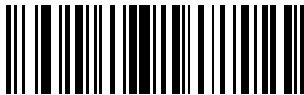
**Skip Ahead  
4 Characters**



**Skip Ahead  
5 Characters**



**Skip Ahead  
6 Characters**



**Skip Ahead  
7 Characters**



**Skip Ahead  
8 Characters**



**Skip Ahead  
9 Characters**



**Skip Ahead  
10 Characters**

## Skip Back

Use the following bar codes to skip back characters.



**Skip Back  
1 Character**



**Skip Back  
2 Characters**



**Skip Back  
3 Characters**



**Skip Back  
4 Characters**



**Skip Back  
5 Characters**



**Skip Back  
6 Characters**



**Skip Back  
7 Characters**



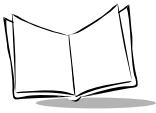
**Skip Back  
8 Characters**



**Skip Back  
9 Characters**



**Skip Back  
10 Characters**



## Send Preset Value

Use these bar codes to send preset values. These values must be set using the prefix/suffix values in [Table A-1 on page A-1](#).



**Send Value 1**



**Send Value 2**



**Send Value 3**



**Send Value 4**



**Send Value 5**

## **Modify Data**

The following bar codes modify data in the ways listed. The following actions work for all send commands that follow it within a rule. Programming *pad zeros to length 6, send next 3 characters, stop padding, send next 5 characters*, to add three zeros to the first send; the next send is unaffected by the padding. These options do not apply to **Send Keystroke** or **Send Preset Value**.

### **Remove All Spaces**

To remove all spaces in the send commands that follow, scan this bar code.

### **Crunch All Spaces**

To leave one space between words, scan this bar code. This also removes all leading and trailing spaces.

### **Stop Space Removal**

Scan this bar code to disable space removal.

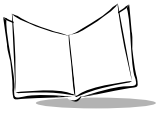
### **Remove Leading Zeros**

Scan this bar code to remove all leading zeros.

### **Stop Zero Removal**

Scan this bar code to disable the removal of zeros.





Use the bar codes below to modify data.



**Remove All Spaces**



**Crunch All Spaces**



**Stop Space Removal**



**Remove Leading  
Zeros**



**Stop Zero Removal**

## ***Pad Data with Spaces***

To pad data to the left, scan the bar code containing the desired number of spaces. This parameter is activated by Send commands.



**Pad Spaces To  
Length 1**



**Pad Spaces To  
Length 2**



**Pad Spaces To  
Length 3**



**Pad Spaces To  
Length 4**



**Pad Spaces To  
Length 5**



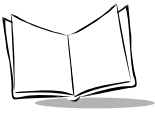
**Pad Spaces To  
Length 6**



**Pad Spaces To  
Length 7**



**Pad Spaces To  
Length 8**



## ***Pad Data with Spaces (continued)***



**Pad Spaces To  
Length 9**



**Pad Spaces To  
Length 10**



**Pad Spaces To  
Length 11**



**Pad Spaces To  
Length 12**



**Pad Spaces To  
Length 13**



**Pad Spaces To  
Length 14**



**Pad Spaces To  
Length 15**



**Pad Spaces To  
Length 16**

## ***Pad Data with Spaces (continued)***



**Pad Spaces To  
Length 17**



**Pad Spaces To  
Length 18**



**Pad Spaces To  
Length 19**



**Pad Spaces To  
Length 20**



**Pad Spaces To  
Length 21**



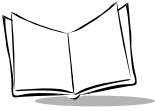
**Pad Spaces To  
Length 22**



**Pad Spaces To  
Length 23**



**Pad Spaces To  
Length 24**



## ***Pad Data with Spaces (continued)***



**Pad Spaces To  
Length 25**



**Pad Spaces To  
Length 26**



**Pad Spaces To  
Length 27**



**Pad Spaces To  
Length 28**



**Pad Spaces To  
Length 29**



**Pad Spaces To  
Length 30**



**Stop Pad Spaces**

## ***Pad Data with Zeros***

To pad data to the left, scan the bar code containing the desired number of zeros. This parameter is activated by Send commands.



**Pad Zeros To  
Length 1**



**Pad Zeros To  
Length 2**



**Pad Zeros To  
Length 3**



**Pad Zeros To  
Length 4**



**Pad Zeros To  
Length 5**



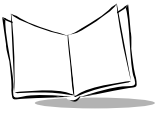
**Pad Zeros To  
Length 6**



**Pad Zeros To  
Length 7**



**Pad Zeros To  
Length 8**



## ***Pad Data with Zeros (continued)***



**Pad Zeros To  
Length 9**



**Pad Zeros To  
Length 10**



**Pad Zeros To  
Length 11**



**Pad Zeros To  
Length 12**



**Pad Zeros To  
Length 13**



**Pad Zeros To  
Length 14**



**Pad Zeros To  
Length 15**



**Pad Zeros To  
Length 16**

## ***Pad Data with Zeros (continued)***



**Pad Zeros To  
Length 17**



**Pad Zeros To  
Length 18**



**Pad Zeros To  
Length 19**



**Pad Zeros To  
Length 20**



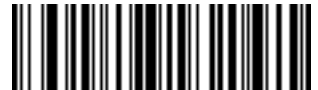
**Pad Zeros To  
Length 21**



**Pad Zeros To  
Length 22**

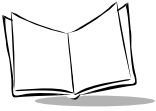


**Pad Zeros To  
Length 23**



**Pad Zeros To  
Length 24**





## ***Pad Data with Zeros (continued)***



**Pad Zeros To  
Length 25**



**Pad Zeros To  
Length 26**



**Pad Zeros To  
Length 27**



**Pad Zeros To  
Length 28**



**Pad Zeros To  
Length 29**



**Pad Zeros To  
Length 30**



**Stop Pad Zeros**

## ***Beeps***

Select a beep sequence for each ADF rule.



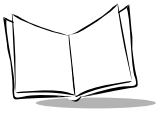
**Beep Once**



**Beep Twice**



**Beep Three Times**



## **Send Keystroke (Control Characters and Keyboard Characters)**

### **Control Characters**

Scan the bar code representing the keystroke you want to send.



**Send Control 2**



**Send Control A**



**Send Control B**



**Send Control C**



**Send Control D**



**Send Control E**



**Send Control F**



**Send Control G**

## Control Characters (continued)



Send Control H



Send Control I



Send Control J



Send Control K



Send Control L



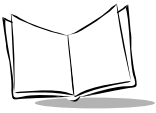
Send Control M



Send Control N



Send Control O



## **Control Characters (continued)**



**Send Control P**



**Send Control Q**



**Send Control R**



**Send Control S**



**Send Control T**



**Send Control U**



**Send Control V**



**Send Control W**

## Control Characters (continued)



Send Control X



Send Control Y



Send Control Z



Send Control [



Send Control \



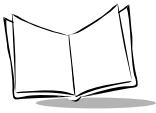
Send Control ]



Send Control 6



Send Control -



## **Keyboard Characters**

Scan the bar code representing the keyboard character you want to send.



**Send Space**



**Send !**



**Send "**



**Send #**



**Send \$**



**Send %**



**Send &**



**Send '**

## Keyboard Characters (continued)



Send (



Send )



Send \*



Send +



Send ,



Send -

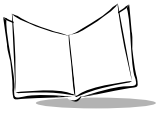


Send .



Send /





## Keyboard Characters (continued)



**Send 0**



**Send 1**



**Send 2**



**Send 3**



**Send 4**



**Send 5**



**Send 6**



**Send 7**

## Keyboard Characters (continued)



Send 8



Send 9



Send :



Send ;



Send <



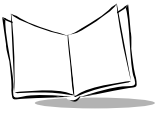
Send =



Send >



Send ?



## Keyboard Characters (continued)



**Send @**



**Send A**



**Send B**



**Send C**



**Send D**



**Send E**



**Send F**



**Send G**

## Keyboard Characters (continued)



Send H



Send I



Send J



Send K



Send L



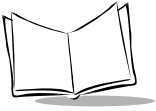
Send M



Send N



Send O



## Keyboard Characters (continued)



**Send P**



**Send Q**



**Send R**



**Send S**



**Send T**



**Send U**



**Send V**



**Send W**

## Keyboard Characters (continued)



Send X



Send Y



Send Z



Send [



Send \



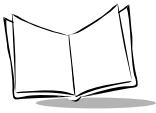
Send ]



Send ^



Send \_



## Keyboard Characters (continued)



Send `



Send a



Send b



Send c



Send d



Send e



Send f



Send g

## Keyboard Characters (continued)



Send h



Send i



Send j



Send k



Send l



Send m

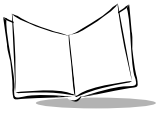


Send n



Send o





## Keyboard Characters (continued)



**Send p**



**Send q**



**Send r**



**Send s**



**Send t**



**Send u**



**Send v**



**Send w**

## Keyboard Characters (continued)



Send x



Send y



Send z



Send {



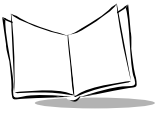
Send |



Send }



Send ~



## Send ALT Characters



**Send Alt 2**



**Send Alt A**



**Send Alt B**



**Send Alt C**



**Send Alt D**



**Send Alt E**



**Send Alt F**



**Send Alt G**

## Send ALT Characters (continued)



Send Alt H



Send Alt I



Send Alt J



Send Alt K



Send Alt L



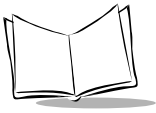
Send Alt M



Send Alt N



Send Alt O



## Send ALT Characters (continued)



**Send Alt P**



**Send Alt Q**



**Send Alt R**



**Send Alt S**



**Send Alt T**



**Send Alt U**



**Send Alt V**



**Send Alt W**

## Send ALT Characters (continued)



Send Alt X



Send Alt Y



Send Alt Z



Send Alt [



Send Alt \



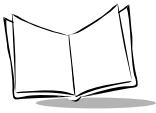
Send Alt ]



Send Alt 6



Send Alt -



## Send Keypad Characters



Send Keypad \*



Send Keypad +



Send Keypad -



Send Keypad .



Send Keypad /



Send Keypad 0



Send Keypad 1



Send Keypad 2



Send Keypad 3



Send Keypad 4

## **Send Keypad Characters (continued)**



**Send Keypad 5**



**Send Keypad 6**



**Send Keypad 7**



**Send Keypad 8**



**Send Keypad 9**

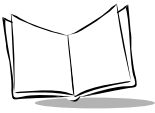


**Send Keypad Enter**



**Send Keypad Numlock**





## Send Keypad Characters (continued)



**Send Break Key**



**Send Delete Key**



**Send Page Up Key**



**Send End Key**



**Send Page Down Key**



**Send Pause Key**



**Send Scroll Lock Key**



**Send Backspace Key**



**Send Tab Key**



**Send Print Screen Key**

## Send Keypad Characters (continued)



Send Insert Key



Send Home Key



Send Enter Key



Send Escape Key



Send Up Arrow Key



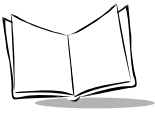
Send Down Arrow Key



Send Left Arrow Key



Send Right Arrow Key



## Send Function Key



Send F1 Key



Send F2 Key



Send F3 Key



Send F4 Key



Send F5 Key



Send F6 Key



Send F7 Key



Send F8 Key



Send F9 Key



Send F10 Key

## Send Function Key (continued)



Send F11 Key



Send F12 Key



Send F13 Key



Send F14 Key



Send F15 Key



Send F16 Key



Send F17 Key



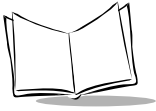
Send F18 Key



Send F19 Key



Send F20 Key



## **Send Function Key (continued)**



**Send F21 Key**



**Send F22 Key**



**Send F23 Key**



**Send F24 Key**

## Send Function Key (continued)



Send PF1 Key



Send PF2 Key



Send PF3 Key



Send PF4 Key



Send PF5 Key



Send PF6 Key



Send PF7 Key



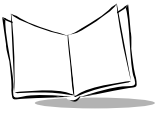
Send PF8 Key



Send PF9 Key



Send PF10 Key



## Send Function Key (continued)



Send PF11 Key



Send PF12 Key



Send PF13 Key



Send PF14 Key



Send PF15 Key



Send PF16 Key



Send PF17 Key



Send PF18 Key



Send PF19 Key



Send PF20 Key

## Send Function Key (continued)



Send PF21 Key



Send PF22 Key



Send PF23 Key



Send PF24 Key



Send PF25 Key



Send PF26 Key



Send PF27 Key



Send PF28 Key

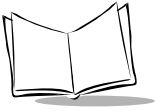


Send PF29 Key



Send PF30 Key





## **Send Right Control Key**

The Send Right Control Key action sends a tap (press and release) of the Right Control Key.



**Send Right Control Key**

## **Send Graphic User Interface (GUI) Characters**

The Send Graphic User Interface Character actions tap the specified key while holding the System Dependent Graphic User Interface (GUI) key. The definition of the Graphic User Interface key depends on the attached system:



**Send GUI 0**



**Send GUI 1**

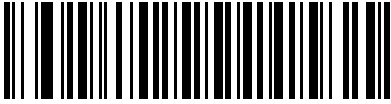


**Send GUI 2**

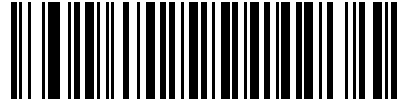


**Send GUI 3**

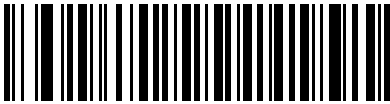
## Send Graphic User Interface (GUI) Characters (continued)



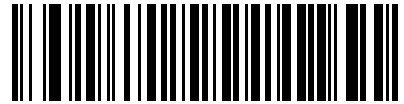
Send GUI 4



Send GUI 5



Send GUI 6



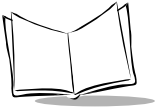
Send GUI 7



Send GUI 8



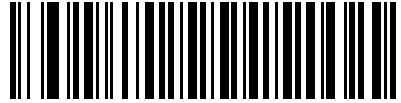
Send GUI 9



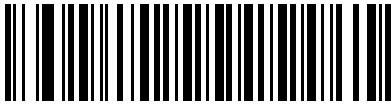
## Send Graphic User Interface (GUI) Characters (continued)



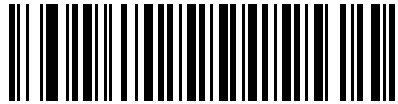
Send GUI A



Send GUI B



Send GUI C



Send GUI D

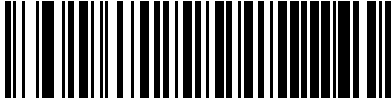


Send GUI E

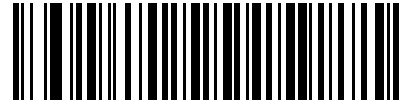


Send GUI F

## Send Graphic User Interface (GUI) Characters (continued)



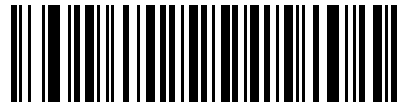
Send GUI G



Send GUI H



Send GUI I



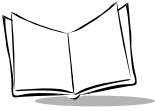
Send GUI J



Send GUI K



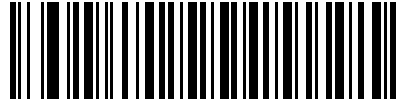
Send GUI L



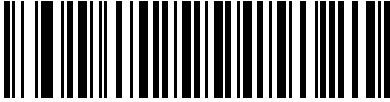
## Send Graphic User Interface (GUI) Characters (continued)



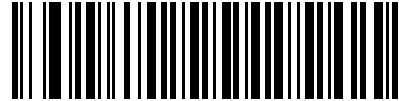
Send GUI M



Send GUI N



Send GUI O



Send GUI P

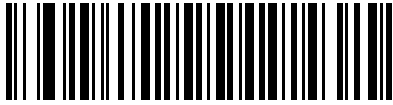


Send GUI Q

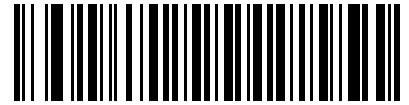


Send GUI R

## Send Graphic User Interface (GUI) Characters (continued)



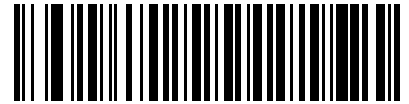
Send GUI S



Send GUI T



Send GUI U



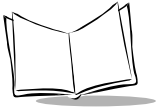
Send GUI V



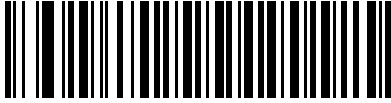
Send GUI W



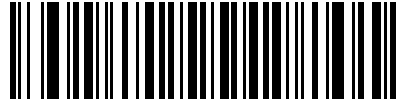
Send GUI X



## ***Send Graphic User Interface (GUI) Characters (continued)***



**Send GUI Y**



**Send GUI Z**

## Turn On/Off Rule Sets

Use these bar codes to turn rule sets on and off.



Turn On Rule Set 1



Turn On Rule Set 2



Turn On Rule Set 3



Turn On Rule Set 4



Turn Off Rule Set 1



Turn Off Rule Set 2

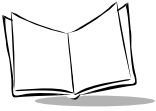


Turn Off Rule Set 3



Turn Off Rule Set 4





# Alphanumeric Keyboard

---



Space



#



\$



%



\*



+



-  
(Dash)



.



/



!

## Alphanumeric Keyboard (continued)

---



“



&



’



(



)



:



;



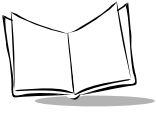
<



=



>



## Alphanumeric Keyboard (continued)

---



?



@



[



\



]



^



            
(Underscore)



~

## Alphanumeric Keyboard (continued)

---

Do not confuse bar codes on this page with those on the numeric keypad.



0



1



2



3



4



5



6



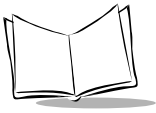
7



8



9



## Alphanumeric Keyboard (continued)

---



A



B



C



D



E



F



G



H



I



J

## Alphanumeric Keyboard (continued)

---



K



L



M



N



O



P



Q



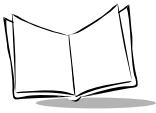
R



S



T



## Alphanumeric Keyboard (continued)

---



U



V



W



X



Y



Z



Cancel



End Of Message

## Alphanumeric Keyboard (continued)

---



a



b



c



d



e



f



g



h

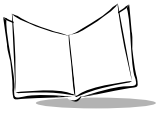


i



j





## Alphanumeric Keyboard (continued)

---



k



l



m



n



o



p



q



r



s



t

## Alphanumeric Keyboard (continued)

---



u



v



w



x



y



z



{



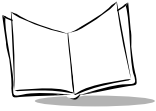
|



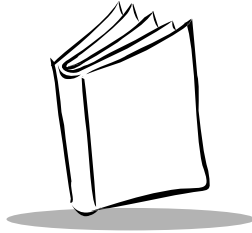
}



~



*MiniScan MS-320X Integration Guide*



## Chapter 12

# Simple Serial Interface (SSI) (MS-3204 Only)

### Simple Serial Interface (SSI)

---

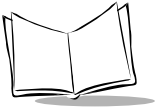
The MS-3204 communicates with a host device using Symbol's Simple Serial Interface (SSI). This interface is only available on MS-3204 models.

The *Simple Serial Interface (SSI) Programmer's Guide* (p/n 72-40451-xx) provides general information on SSI, includes information on the decoder's hardware signals, and describes the commands. The following SSI information is specific to the MiniScan scanner.

---

**Note:** *The MS-3204 only supports Multipackaging Option 1. See the SSI Programmer's Guide for more information.*

---



## Revision String

When the decoder sends the `REPLY_REVISION` message, the revision string is in the following format:

```
SW_REVISION <space> BOARD_TYPE <space> ENGINE_CODE <space> PGM_CHKSUM
```

Where:

- **SW\_REVISION** is the release name of the software
- **BOARD\_TYPE** is *N* for non-flash decoder board, *F* for flash
- **ENGINE\_CODE** indicates the type of scanner paired with the decoder
- **PGM\_CHKSUM** is the two byte checksum of the program code.

Table 12-1 lists the codes identifying the MiniScan scanner when using SSI.

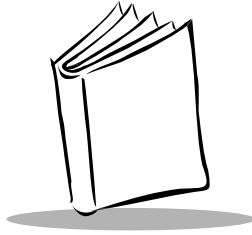
**Table 12-1. MiniScan Codes**

Code	Description
48h	MS-3204-I000, MS-3207
4ch	MS-3204-E000

## SSI Commands Not Supported

The following SSI Commands included in the *Simple Serial Interface (SSI) Programmer's Guide* are NOT supported by the MiniScan scanner:

- C4h      AIM\_OFF
- C5h      AIM\_ON
- B1h      IMAGE\_DATA
- F7h      IMAGER\_MODE
- B4h      VIDEO\_DATA



## *Chapter 13*

# *Mounting Template*

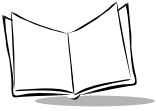
### **Overview**

---

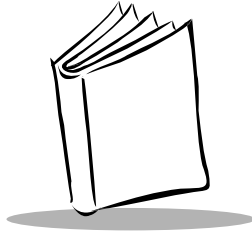
This chapter provides a mounting template for the MiniScan scanner. Tear out the page to use the template.



**Figure 13-1. Mounting Template**



*MiniScan MS-320X Integration Guide*



# Appendix A

## ASCII Character Set

### RS-232 ASCII Character Set

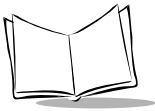
---

The values in [Table A-1](#) can be assigned as prefixes or suffixes for ASCII character data transmission in an RS-232 environment.

**Table A-1. Prefix/Suffix Values**

Prefix/Suffix Value	Full ASCII Code 39 Encode Character	ASCII Character
1000	%U	NUL
1001	\$A	SOH
1002	\$B	STX
1003	\$C	ETX
1004	\$D	EOT
1005	\$E	ENQ
1006	\$F	ACK
1007	\$G	BELL
1008	\$H	BACKSPACE
1009	\$I	HORIZONTAL TAB
1010	\$J	LF/NEW LINE
1011	\$K	VT



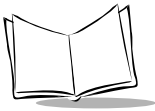


**Table A-1. Prefix/Suffix Values (Continued)**

<b>Prefix/Suffix Value</b>	<b>Full ASCII Code 39 Encode Character</b>	<b>ASCII Character</b>
1012	\$L	FF
1013	\$M	CR/ENTER
1014	\$N	SO
1015	\$O	SI
1016	\$P	DLE
1017	\$Q	DC1
1018	\$R	DC2
1019	\$S	DC3
1020	\$T	DC4
1021	\$U	NAK
1022	\$V	SYN
1023	\$W	ETB
1024	\$X	CAN
1025	\$Y	EM
1026	\$Z	SUB
1027	%A	ESC
1028	%B	FS
1029	%C	GS
1030	%D	RS
1031	%E	US
1032	Space	Space
1033	/A	!
1034	/B	"
1035	/C	#
1036	/D	\$
1037	/E	%

Table A-1. Prefix/Suffix Values (Continued)

Prefix/Suffix Value	Full ASCII Code 39 Encode Character	ASCII Character
1038	/F	&
1039	/G	'
1040	/H	(
1041	/I	)
1042	/J	*
1043	/K	+
1044	/L	,
1045	-	-
1046	.	.
1047	/O	/
1048	0	0
1049	1	1
1050	2	2
1051	3	3
1052	4	4
1053	5	5
1054	6	6
1055	7	7
1056	8	8
1057	9	9
1058	/Z	:
1059	%F	;
1060	%G	<
1061	%H	=
1062	%I	>
1063	%J	?

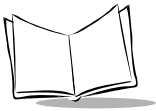


**Table A-1. Prefix/Suffix Values (Continued)**

<b>Prefix/Suffix Value</b>	<b>Full ASCII Code 39 Encode Character</b>	<b>ASCII Character</b>
1064	%V	@
1065	A	A
1066	B	B
1067	C	C
1068	D	D
1069	E	E
1070	F	F
1071	G	G
1072	H	H
1073	I	I
1074	J	J
1075	K	K
1076	L	L
1077	M	M
1078	N	N
1079	O	O
1080	P	P
1081	Q	Q
1082	R	R
1083	S	S
1084	T	T
1085	U	U
1086	V	V
1087	W	W
1088	X	X
1089	Y	Y

Table A-1. Prefix/Suffix Values (Continued)

Prefix/Suffix Value	Full ASCII Code 39 Encode Character	ASCII Character
1090	Z	Z
1091	%K	[
1092	%L	\
1093	%M	]
1094	%N	^
1095	%O	_
1096	%W	`
1097	+A	a
1098	+B	b
1099	+C	c
1100	+D	d
1101	+E	e
1102	+F	f
1103	+G	g
1104	+H	h
1105	+I	i
1106	+J	j
1107	+K	k
1108	+L	l
1109	+M	m
1110	+N	n
1111	+O	o
1112	+P	p
1113	+Q	q
1114	+R	r
1115	+S	s



**Table A-1. Prefix/Suffix Values (Continued)**

<b>Prefix/Suffix Value</b>	<b>Full ASCII Code 39 Encode Character</b>	<b>ASCII Character</b>
1116	+T	t
1117	+U	u
1118	+V	v
1119	+W	w
1120	+X	x
1121	+Y	y
1122	+Z	z
1123	%P	{
1124	%Q	
1125	%R	}
1126	%S	~
1127		Undefined
7013		ENTER

## USB ASCII Character Set

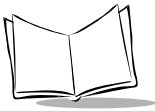
---

The values in [Table A-2](#) can be used for ASCII character data transmission in a USB environment.

**Table A-2. USB ASCII Character Set**

Prefix/ Suffix Value	Full ASCII Code 39 Encode Char.	Keystroke
1000	%U	CTRL 2
1001	\$A	CTRL A
1002	\$B	CTRL B
1003	\$C	CTRL C
1004	\$D	CTRL D
1005	\$E	CTRL E
1006	\$F	CTRL F
1007	\$G	CTRL G
1008	\$H	CTRL H / <b>BACKSPACE*</b>
1009	\$I	CTRL I / <b>HORIZONTAL TAB*</b>
1010	\$J	CTRL J
1011	\$K	CTRL K
1012	\$L	CTRL L
1013	\$M	CTRL M / <b>ENTER*</b>
1014	\$N	CTRL N
1015	\$O	CTRL O
1016	\$P	CTRL P
1017	\$Q	CTRL Q
1018	\$R	CTRL R
1019	\$S	CTRL S
1020	\$T	CTRL T

\*The keystroke in bold is sent only if Function Key Mapping is enabled.



**Table A-2. USB ASCII Character Set (Continued)**

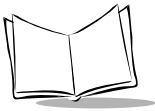
1021	\$U	CTRL U
1022	\$V	CTRL V
1023	\$W	CTRL W
1024	\$X	CTRL X
1025	\$Y	CTRL Y
1026	\$Z	CTRL Z
1027	%A	NONE / <b>ESC*</b>
1028	%B	CTRL \
1029	%C	CTRL ]
1030	%D	CTRL 6
1031	%E	CTRL -
1032	Space	Space
1033	/A	!
1034	/B	“
1035	/C	#
1036	/D	\$
1037	/E	%
1038	/F	&
1039	/G	‘
1040	/H	(
1041	/I	)
1042	/J	*
1043	/K	+
1044	/L	,
1045	-	-
1046	.	.

\*The keystroke in bold is sent only if Function Key Mapping is enabled.

**Table A-2. USB ASCII Character Set (Continued)**

1047	/o	/
1048	0	0
1049	1	1
1050	2	2
1051	3	3
1052	4	4
1053	5	5
1054	6	6
1055	7	7
1056	8	8
1057	9	9
1058	/Z	:
1059	%F	;
1060	%G	<
1061	%H	=
1062	%I	>
1063	%J	?
1064	%V	@
1065	A	A
1066	B	B
1067	C	C
1068	D	D
1069	E	E
1070	F	F
1071	G	G
1072	H	H
*The keystroke in bold is sent only if Function Key Mapping is enabled.		





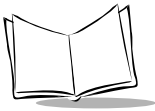
**Table A-2. USB ASCII Character Set (Continued)**

1073	I	I
1074	J	J
1075	K	K
1076	L	L
1077	M	M
1078	N	N
1079	O	O
1080	P	P
1081	Q	Q
1082	R	R
1083	S	S
1084	T	T
1085	U	U
1086	V	V
1087	W	W
1088	X	X
1089	Y	Y
1090	Z	Z
1091	<b>%K</b>	[
1092	<b>%L</b>	\
1093	<b>%M</b>	]
1094	<b>%N</b>	^
1095	<b>%O</b>	_
1096	<b>%W</b>	`
1097	<b>+A</b>	a
1098	<b>+B</b>	b

\*The keystroke in bold is sent only if Function Key Mapping is enabled.

Table A-2. USB ASCII Character Set (Continued)

1099	+C	c
1100	+D	d
1101	+E	e
1102	+F	f
1103	+G	g
1104	+H	h
1105	+I	i
1106	+J	j
1107	+K	k
1108	+L	l
1109	+M	m
1110	+N	n
1111	+O	o
1112	+P	p
1113	+Q	q
1114	+R	r
1115	+S	s
1116	+T	t
1117	+U	u
1118	+V	v
1119	+W	w
1120	+X	x
1121	+Y	y
1122	+Z	z
1123	%P	{
1124	%Q	
*The keystroke in bold is sent only if Function Key Mapping is enabled.		

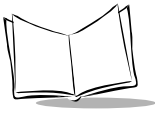


**Table A-2. USB ASCII Character Set (Continued)**

1125	%R	}
1126	%S	~
<b>ALT Keys</b>	<b>Keystroke</b>	
2064	ALT 2	
2065	ALT A	
2066	ALT B	
2067	ALT C	
2068	ALT D	
2069	ALT E	
2070	ALT F	
2071	ALT G	
2072	ALT H	
2073	ALT I	
2074	ALT J	
2075	ALT K	
2076	ALT L	
2077	ALT M	
2078	ALT N	
2079	ALT O	
2080	ALT P	
2081	ALT Q	
2082	ALT R	
2083	ALT S	
2084	ALT T	
2085	ALT U	
2086	ALT V	
*The keystroke in bold is sent only if Function Key Mapping is enabled.		

Table A-2. USB ASCII Character Set (Continued)

2087	ALT W
2088	ALT X
2089	ALT Y
2090	ALT Z
<p>GUI Shift Keys</p> <p>The Apple™ iMac keyboard has an apple key on either side of the space bar. Windows-based systems have a GUI key to the left of the left ALT key, and to the right of the right ALT key.</p>	
<b>Other Value</b>	<b>Keystroke</b>
3000	Right Control Key
3048	GUI 0
3049	GUI 1
3050	GUI 2
3051	GUI 3
3052	GUI 4
3053	GUI 5
3054	GUI 6
3055	GUI 7
3056	GUI 8
3057	GUI 9
3065	GUI A
3066	GUI B
3067	GUI C
3068	GUI D
3069	GUI E
3070	GUI F
3071	GUI G
3072	GUI H
*The keystroke in bold is sent only if Function Key Mapping is enabled.	

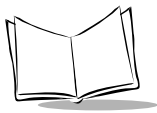


**Table A-2. USB ASCII Character Set (Continued)**

3073	GUI I
3074	GUI J
3075	GUI K
3076	GUI L
3077	GUI M
3078	GUI N
3079	GUI O
3080	GUI P
3081	GUI Q
3082	GUI R
3083	GUI S
3084	GUI T
3085	GUI U
3086	GUI V
3087	GUI W
3088	GUI X
3089	GUI Y
3090	GUI Z
<b>F Keys</b>	<b>Keystroke</b>
5001	F1
5002	F2
5003	F3
5004	F4
5005	F5
5006	F6
5007	F7
*The keystroke in bold is sent only if Function Key Mapping is enabled.	

Table A-2. USB ASCII Character Set (Continued)

5008	F8
5009	F9
5010	F10
5011	F11
5012	F12
5013	F13
5014	F14
5015	F15
5016	F16
5017	F17
5018	F18
5019	F19
5020	F20
5021	F21
5022	F22
5023	F23
5024	F24
<b>Keypad</b>	<b>Keystroke</b>
6042	*
6043	+
6044	undefined
6045	-
6046	.
6047	/
6048	0
6049	1
*The keystroke in bold is sent only if Function Key Mapping is enabled.	



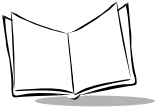
**Table A-2. USB ASCII Character Set (Continued)**

6050	2
6051	3
6052	4
6053	5
6054	6
6055	7
6056	8
6057	9
6058	Enter
6059	Num Lock
<b>Extended Keypad</b>	<b>Keystroke</b>
7001	Break
7002	Delete
7003	PgUp
7004	End
7005	Pg Dn
7006	Pause
7007	Scroll Lock
7008	Backspace
7009	Tab
7010	Print Screen
7011	Insert
7012	Home
7013	Enter
7014	Escape
7015	Up Arrow
*The keystroke in bold is sent only if Function Key Mapping is enabled.	

**Table A-2. USB ASCII Character Set (Continued)**

7016	Down Arrow
7017	Left Arrow
7018	Right Arrow
*The keystroke in bold is sent only if Function Key Mapping is enabled.	



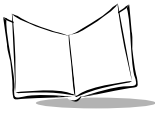


*MiniScan MS-320X Integration Guide*



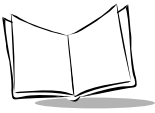
# *Glossary*

<b>Aperture</b>	An opening which limits the amount of light or radiation passing through an optical system.
<b>ASCII</b>	American Standard Code for Information Interchange. A 7 bit-plus-parity code representing 128 letters, numerals, punctuation marks, and control characters. It is a standard data transmission code in the U.S.
<b>Autodiscrimination</b>	The ability of an interface controller to determine the code type of a scanned bar code. After this determination is made, the information content can be decoded.
<b>Bar</b>	The dark element in a printed bar code symbol.
<b>Bar Code Density</b>	The number of characters represented per unit of measurement (e.g., characters per inch).
<b>Bar Height</b>	The dimension of a bar measured perpendicular to the bar width.
<b>Bar Width</b>	Thickness of a bar measured from the edge closest to the symbol start character to the trailing edge of the same bar.
<b>Baud Rate</b>	A measure of the data flow or number of signaling events occurring per second. When one bit is the standard “event,” this is a measure of bits per second (bps). For example, a baud rate of 50 means transmission of 50 bits of data per second.
<b>Bit</b>	Binary digit. One bit is the basic unit of binary information. Generally, eight consecutive bits compose one byte of data. The pattern of 0 and 1 values within the byte determines its meaning.



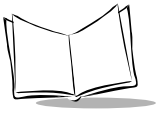
<b>Byte</b>	On an addressable boundary, eight adjacent binary digits (0 and 1) combined in a pattern to represent a specific character or numeric value. Bits are numbered from the right, 0 through 7, with bit 0 the low-order bit. One byte in memory can be used to store one ASCII character.
<b>CDRH</b>	Center for Devices and Radiological Health. A federal agency responsible for regulating laser product safety. This agency specifies various laser operation classes based on power output during operation.
<b>CDRH Class 1</b>	This is the lowest power CDRH laser classification. CDRH Class I devices are safe under reasonably foreseeable conditions of operation. Software and other controls to limit exposure to laser light may be required to achieve CDRH Class I operation. The CDRH time base for Class I devices is 10,000 seconds.
<b>CDRH Class 2</b>	CDRH Class II devices may not emit more than 1 milliwatt average radiant power. Eye protection for CDRH Class II devices is normally afforded by aversion responses, including the blink reflex.
<b>Character</b>	A pattern of bars and spaces which either directly represents data or indicates a control function, such as a number, letter, punctuation mark, or communications control contained in a message.
<b>Character Set</b>	Those characters available for encodation in a particular bar code symbology.
<b>Check Digit</b>	A digit used to verify a correct symbol decode. The scanner inserts the decoded data into an arithmetic formula and checks that the resulting number matches the encoded check digit. Check digits are required for UPC but are optional for other symbologies. Using check digits decreases the chance of substitution errors when a symbol is decoded.
<b>CLSI Editing</b>	An option which inserts a space after the 1st, 5th, and 10th characters of a 14-character Codabar symbol. Length does not include start and stop characters.
<b>Codabar</b>	A discrete self-checking code with a character set consisting of digits 0 to 9 and six additional characters: (- \$ : / , +).
<b>Code 128</b>	A high density symbology which allows the controller to encode all 128 ASCII characters without adding extra symbol elements.

<b>Code 3 of 9 (Code 39)</b>	A versatile and widely used alphanumeric bar code symbology with a set of 43 character types, including all uppercase letters, numerals from 0 to 9, and 7 special characters (- . / + % \$ and space). The code name is derived from the fact that 3 of 9 elements representing a character are wide, while the remaining 6 are narrow.
<b>Code 93</b>	An industrial symbology compatible with Code 39 but offering a full character ASCII set and a higher coding density than Code 39.
<b>Code Length</b>	Number of data characters in a bar code between the start and stop characters, not including those characters.
<b>Continuous Code</b>	A bar code or symbol in which all spaces within the symbol are parts of characters. There are no intercharacter gaps in a continuous code. The absence of gaps allows for greater information density.
<b>CTS</b>	Clear to send.
<b>Dead Zone</b>	An area within a scanner's field of view, in which specular reflection may prevent a successful decode.
<b>Decode</b>	To recognize a bar code symbology (e.g., UPC/EAN) and then analyze the content of the specific bar code scanned.
<b>Decode Algorithm</b>	A decoding scheme that converts pulse widths into data representation of the letters or numbers encoded within a bar code symbol.
<b>Depth of Field</b>	The range between minimum and maximum distances at which a scanner can read a symbol with a certain minimum element width.
<b>Digitized Bar Pattern (DBP)</b>	A digital representation of a decoded bar code.
<b>Discrete 2 of 5</b>	A binary bar code symbology representing each character by a group of five bars, two of which are wide. The location of wide bars in the group determines which character is encoded; spaces are insignificant. Only numeric characters (0 to 9) and START/STOP characters may be encoded.
<b>Discrete Code</b>	A bar code or symbol in which the spaces between characters (intercharacter gaps) are not part of the code.

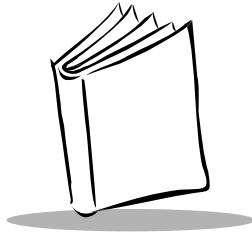


<b>EAN</b>	European Article Number. This European/International version of the UPC provides its own coding format and symbology standards. Element dimensions are specified metrically. EAN is used primarily in retail.
<b>Element</b>	Generic term for a bar or space.
<b>Encoded Area</b>	Total linear dimension occupied by all characters of a code pattern, including start/stop characters and data.
<b>Host Computer</b>	A computer that serves other terminals in a network, providing such services as computation, database access, supervisory programs, and network control.
<b>IEC</b>	International Electrotechnical Commission. This international agency regulates laser safety by specifying various laser operation classes based on power output during operation.
<b>IEC (825) Class 1</b>	This is the lowest power IEC laser classification. IEC Class I devices are safe under reasonably foreseeable conditions of operation. Software and other controls to limit exposure to laser light may be required to achieve IEC Class 1 operation. The IEC time base for Class 1 devices is 100 seconds if intentional viewing of laser light is not required in the design or function of the device. The IEC time base for Class 1 devices is 30,000 seconds where intentional viewing of laser light is inherent in the design or function of the device.
<b>IEC (825) Class 2</b>	IEC Class 2 devices may not emit more than 1 milliwatt average radiant power. Eye protection for IEC Class 2 devices is normally afforded by aversion responses, including the blink reflex.
<b>Intercharacter Gap</b>	The space between two adjacent bar code characters in a discrete code.
<b>Interleaved Bar Code</b>	A bar code in which characters are paired together, using bars to represent the first character and the intervening spaces to represent the second.
<b>Interleaved 2 of 5</b>	A binary bar code symbology representing character pairs in groups of five bars and five interleaved spaces. Interleaving provides for greater information density. The location of wide elements (bar/spaces) within each group determines which characters are encoded. This continuous code type uses no intercharacter spaces. Only numeric (0 to 9) and START/STOP characters may be encoded.

<b>LASER - Light Amplification by Stimulated Emission of Radiation</b>	The laser is an intense light source. Light from a laser is all the same frequency, unlike the output of an incandescent bulb. Laser light is typically coherent and has a high energy density.
<b>Laser Diode</b>	A gallium-arsenide semiconductor type of laser connected to a power source to generate a laser beam. This laser type is a compact source of coherent light.
<b>LED Indicator</b>	A semiconductor diode (LED - Light Emitting Diode) used as an indicator, often in digital displays. The semiconductor uses applied voltage to produce light of a certain frequency determined by the semiconductor's particular chemical composition.
<b>MIL</b>	1 mil = 1 thousandth of an inch.
<b>Misread (Misdecode)</b>	A condition which occurs when the data output of a reader or interface controller does not agree with the data encoded within a bar code symbol.
<b>MSI Plessey</b>	A numeric-only bar code type. It can accept a variable number of digits up to 13. MSI Plessey consists of four bars and four adjacent spaces. Each bar\space pair consists of one information bit. A zero bit consists of a narrow bar followed by a wide space, while one bit consist of a wide bar followed by a narrow bar. The zero bit is one unit bar followed by a two-unit space and the one bit is a two-unit bar followed by a one unit space. The primary application for the MSI Plessey code is marking of retail shelves and subsequent scanning with portable devices for inventory purposes.
<b>Nominal</b>	The exact (or ideal) intended value for a specified parameter. Tolerances are specified as positive and negative deviations from this value.
<b>Nominal Size</b>	Standard size for a bar code symbol. Most UPC/EAN codes can be used over a range of magnifications (e.g., from 0.80 to 2.00 of nominal).
<b>NOTIS Editing</b>	An option that strips the start and stop characters from a decoded Codabar symbol.
<b>Parameter</b>	A variable that can have different values assigned to it.
<b>Percent Decode</b>	The average probability that a single scan of a bar code would result in a successful decode. In a well-designed bar code scanning system, that probability should approach near 100%.



<b>Print Contrast Signal (PCS)</b>	Measurement of the contrast (brightness difference) between the bars and spaces of a symbol. A minimum PCS value is needed for a bar code symbol to be scannable. $PCS = (R_L - R_D) / R_L$ , where $R_L$ is the reflectance factor of the background and $R_D$ the reflectance factor of the dark bars.
<b>Programming Mode</b>	The state in which a scanner is configured for parameter values. See <i>Scanning Mode</i> .
<b>Quiet Zone</b>	A clear space, containing no dark marks, which precedes the start character of a bar code symbol and follows the stop character.
<b>Random Access Memory (RAM)</b>	Memory devices where any location in memory can be accessed as quickly as any other location.
<b>Reflectance</b>	Amount of light returned from an illuminated surface.
<b>Resolution</b>	The narrowest element dimension which can be distinguished by a particular reading device or printed with a particular device or method.
<b>RTS</b>	Request to send.
<b>RSS</b>	Reduced Space Symbology: A family of space efficient symbologies developed by UCC.EAN.
<b>RxD</b>	Received data.
<b>Scan Area</b>	Area intended to contain a symbol.



# Index

## Numerics

123Scan parameters ..... 10-2

## A

accessories

    required ..... 2-15

actions ..... 11-3

ADF ..... 11-1

    actions ..... 11-1, 11-24

        move cursor ..... 11-29

        send data ..... 11-25

        setup fields ..... 11-28

    alphanumeric keyboard ..... 11-82

    alternate rule sets ..... 11-4

    bar code menu example ..... 11-3

    beep ..... 11-43

    code lengths ..... 11-15

    code types ..... 11-12

    criteria ..... 11-1, 11-12

    default rules ..... 11-7

    move cursor past a character ..... 11-28

    move cursor to a character ..... 11-28

    move cursor to start of data ..... 11-28

    numeric keypad ..... 11-22

    pad spaces ..... 11-35

    pad zeros ..... 11-39

    rules ..... 11-1

    rules hierarchy ..... 11-6

    send alt characters ..... 11-60

    send control characters ..... 11-44

    send function key ..... 11-68

    send keyboard characters ..... 11-48

    send keypad characters ..... 11-64

    send preset value ..... 11-28

    send value ..... 11-32

    skip ahead characters ..... 11-30

    skip ahead "n" characters ..... 11-28

    skip back characters ..... 11-31

    skip back "n" characters ..... 11-28

    space removal ..... 11-33

    special commands ..... 11-8

    specific data string ..... 11-20

    specific string

        any location ..... 11-21

        any message ok ..... 11-21

        at start ..... 11-20

        rule belongs to set ..... 11-23

        turn off rule sets ..... 11-81

        zero removal ..... 11-33

    advanced data formatting ..... 11-1

    actions ..... 11-1, 11-24

    alphanumeric keyboard ..... 11-82

    alternate rule sets ..... 11-4

    bar code menu example ..... 11-3

    beep ..... 11-43

    code lengths ..... 11-15

    code types ..... 11-12

    criteria ..... 11-1, 11-12

    default rules ..... 11-7

    numeric keypad ..... 11-22

    pad spaces ..... 11-35

    pad zeros ..... 11-39

    rules ..... 11-1

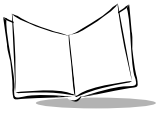
    rules hierarchy ..... 11-6

    send alt characters ..... 11-60

    send control characters ..... 11-44

    send function key ..... 11-68





- send keyboard characters . . . . . 11-48
- send keypad characters . . . . . 11-64
- send preset value . . . . . 11-32
- setup fields . . . . . 11-28
- skip ahead characters . . . . . 11-30
- skip back characters . . . . . 11-31
- space removal . . . . . 11-33
- special commands . . . . . 11-8
- specific data string . . . . . 11-20
- turn off rule sets . . . . . 11-81
- zero removal . . . . . 11-33
- aiming . . . . . 5-3
- aiming modes . . . . . 7-20
- ASCII character set . . . . . A-1

**B**

- bar codes
  - 123Scan . . . . . 10-2
  - data options
    - pause duration . . . . . 11-8
  - RS-232
    - baud rate . . . . . 8-8
    - Data Bits . . . . . 8-12
    - default table . . . . . 8-2
    - hardware handshaking . . . . . 8-14
    - host serial response time-out . . . . . 8-19
    - host types . . . . . 8-6
    - intercharacter delay . . . . . 8-21
    - RTS line state . . . . . 8-20
    - stop bit select . . . . . 8-20
  - RS-232 parameters
    - check receive errors . . . . . 8-13
    - parity . . . . . 8-10
    - software handshaking . . . . . 8-16
  - RS-232C
    - beep on bel . . . . . 8-20
  - serial parameters
    - software handshaking . . . . . 7-119
  - set defaults . . . . . 7-10
  - USB
    - caps lock override . . . . . 9-9
    - country keyboard types . . . . . 9-5
    - default table . . . . . 9-3

- device type . . . . . 9-4
- keystroke delay . . . . . 9-8
- unknown characters . . . . . 9-10

- beeper
  - definitions . . . . . 1-8
- beeper definitions . . . . . 1-8
- block diagram . . . . . 1-3
- bullets . . . . . xii

**C**

- code types
  - ADF . . . . . 11-12
- codewords . . . . . 7-128
  - transmit unknown . . . . . 7-130
- conventions
  - notational . . . . . xii
- conveyor belt velocity . . . . . 2-12

**D**

- default parameters
  - RS-232 . . . . . 8-2
  - USB . . . . . 9-3
- default table . . . . . 7-3
- depth . . . . . 3-4, 4-5

**E**

- ECI
  - decoder . . . . . 7-133
  - delete character set ECIs . . . . . 7-132
- electrical interface
  - MS 3204-I000 . . . . . 4-2
- escape characters . . . . . 7-131

**H**

- height . . . . . 3-4, 4-5
- host types
  - RS-232 . . . . . 8-6

**I**

- information, service . . . . . xii
- installation

mounting scanner on stand ..... 2-3  
 interface pin-outs ..... 3-2, 4-2

**L**

laser class ..... 3-4, 4-5  
   MS-3204 ..... 3-4  
   MS-3207 ..... 4-5

**LED**

definitions ..... 1-8

**M****macro PDF**

delete character set ECIs ..... 7-132  
 ECI decoder ..... 7-133  
 escape characters ..... 7-131  
 last blocker marker ..... 7-142  
 transmit addressee ..... 7-138  
 transmit block count ..... 7-135  
 transmit checksum ..... 7-139  
 transmit file name ..... 7-134  
 transmit filesize ..... 7-140  
 transmit macro PDF control header ..... 7-141  
 transmit sender ..... 7-137  
 transmit symbols in codeword  
   format ..... 7-128  
 transmit time stamp ..... 7-136  
 transmit unknown codewords ..... 7-130  
 transmit user-selected fields ..... 7-134

maintenance ..... 6-1

media CD ..... 2-16

mounting template ..... 13-1

mounting the stand ..... 2-4

**N**

notational conventions ..... xii

**O**

operational parameters ..... 7-1

**P**

parameters

RS-232 ..... 8-4

USB ..... 9-4

parameters, operational ..... 7-1

**programming bar codes**

aiming mode ..... 7-20

beep after good decode ..... 7-23

beeper frequency adjustment ..... 7-14

beeper tone ..... 7-13

beeper volume ..... 7-12

bi-directional redundancy ..... 7-28

cancel ..... 7-145

Codabar ..... 7-84

  CLSI editing ..... 7-87

  enable/disable ..... 7-84

  length ..... 7-85

  NOTIS editing ..... 7-88

Code 11 ..... 7-70

  check digit verification ..... 7-73

  lengths ..... 7-71

  transmit check digit ..... 7-74

Code 128 ..... 7-51

  decode performance ..... 7-54

  lengths ..... 7-53

  UCC/EAN-128 ..... 7-52

Code 128 emulation ..... 7-98

Code 39 ..... 7-56

  check digit verification ..... 7-62

  Code 39 full ASCII ..... 7-64

  decode performance ..... 7-65

  lengths ..... 7-60

  transmit check digit ..... 7-63

  Trioptic Code 39 ..... 7-57

Code 93

  lengths ..... 7-68

composite CC-A/B ..... 7-102

composite CC-C ..... 7-102

delete character set ECIs ..... 7-132

Discrete 2 of 5

  lengths ..... 7-82

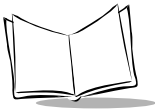
ECI decoder ..... 7-133

escape characters ..... 7-131

event reporting ..... 7-124–7-127

  boot up event ..... 7-126

  decode event ..... 7-125



- parameter event ..... 7-127
- Interleaved 2 of 5 ..... 7-75
  - check digit verification ..... 7-78
  - convert I 2 of 5 to EAN-13 ..... 7-80
  - lengths ..... 7-76
  - transmit check digit ..... 7-79
- ISBT 128
  - enable/disable ..... 7-53
- laser on time ..... 7-15
- last blocker marker ..... 7-142
- linear code type security ..... 7-26
- linear UPC/EAN decode ..... 7-50
- MicroPDF417 ..... 7-96
- MicroPDF-417
  - performance ..... 7-97
- MSI plessey ..... 7-89
  - check digit algorithm ..... 7-94
  - check digits ..... 7-92
  - lengths ..... 7-90
  - transmit check digit ..... 7-93
- numeric bar codes ..... 7-143–7-145
- PDF417 ..... 7-95
- power mode ..... 7-16
- prefix/suffix values ..... 7-108
- programmable raster size/expansion ..... 7-21
- RSS-14 ..... 7-99
- RSS-Limited ..... 7-101
- scan data transmission
  - format ..... 7-110, 7-112
- scanning mode ..... 7-19
- serial parameters
  - baud rate ..... 7-114
  - check parity ..... 7-118
  - data packet format ..... 7-121
  - host RTS line state ..... 7-120
  - host serial response time-out .. 7-123
  - intercharacter delay ..... 7-123
  - parity ..... 7-116
  - stop bit select ..... 7-122
- set defaults ..... 7-11
- SSI options ..... 7-114
- timeout between decodes ..... 7-22
- transmit addressee ..... 7-138
- transmit block count ..... 7-135

- transmit checksum ..... 7-139
- transmit code ID character ..... 7-106
- transmit file name ..... 7-134
- transmit filesize ..... 7-140
- transmit macro PDF control header ..... 7-141
- transmit macro PDF user-selected fields ..... 7-134
- transmit no read message ..... 7-24, 7-25
- transmit sender ..... 7-137
- transmit symbols in codeword
  - format ..... 7-128
- transmit time stamp ..... 7-136
- transmit unknown codewords ..... 7-130
- trigger modes ..... 7-17
- UPC composite mode ..... 7-105
- UPC/EAN ..... 7-29
  - bookland EAN ..... 7-34
  - convert UPC-E to UPC-A ..... 7-45
  - convert UPC-E1 to UPC-A ..... 7-46
  - coupon code ..... 7-35
  - decode supplementals ..... 7-36
  - EAN zero extend ..... 7-47
  - EAN-13 ..... 7-33
  - EAN-8 ..... 7-32
  - security level ..... 7-48
  - supplemental redundancy ..... 7-38
  - supplementals ..... 7-37
  - UPC-A ..... 7-29
    - UPC-A check digit ..... 7-39
    - UPC-A preamble ..... 7-42
  - UPC-E ..... 7-30
    - UPC-E check digit ..... 7-40
    - UPC-E preamble ..... 7-43
  - UPC-E1 ..... 7-31
    - UPC-E1 check digit ..... 7-41
    - UPC-E1 preamble ..... 7-44

**R**

- RS-232 default parameters ..... 8-2
- RS-232 parameters ..... 8-4, 8-6

**S**

- scan patterns

- cyclone omnidirectional ..... 1-6
- raster ..... 1-5
- scanning modes ..... 7-19
- scanning tips ..... 5-1
- service information ..... xii
- set up ..... 2-1
- setup
  - connecting a USB interface ..... 9-2
- Simple Serial Interface ..... 12-1
- software development kit ..... 2-16
- SSI
  - Commands not Supported ..... 12-2
  - Revision String ..... 12-2
- stand
  - mounting ..... 2-4
  - mounting scanner ..... 2-3

**T**

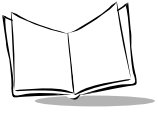
- technical specifications
  - MS-3204 ..... 3-3
  - MS-3207 ..... 4-4
- triggering
  - host ..... 5-2
- troubleshooting ..... 6-1

**U**

- USB connection ..... 9-2
- USB default parameters ..... 9-3
- USB parameters ..... 9-4

**W**

- warranty ..... xvi
- weight ..... 3-4, 4-5
- width ..... 3-4, 4-5



*MiniScan MS-320X Integration Guide*

# ***Tell Us What You Think...***

We'd like to know what you think about this Manual. Please take a moment to fill out this questionnaire and fax this form to: (631) 738-3318, or mail to:

Symbol Technologies, Inc.  
One Symbol Plaza M/S B-4  
Holtsville, NY 11742-1300  
Attention: Technical Publications Manager

**IMPORTANT:** If you need product support, please call the appropriate customer support number provided. Unfortunately, we cannot provide customer support at the fax number above.

User's Manual Title: \_\_\_\_\_  
(please include revision level)

How familiar were you with this product before using this manual?

Very familiar     Slightly familiar     Not at all familiar

Did this manual meet your needs? If not, please explain.

---

---

What topics need to be added to the index, if applicable?

---

---

What topics do you feel need to be better discussed? Please be specific.

---

---

What can we do to further improve our manuals?

---

---

Thank you for your input—We value your comments.



## **MiniScan MS-320X Integration Guide**



**72-58810-02**  
**Revision A — October 2003**