



## Switch HPE OfficeConnect 1405

Projetados para alta confiabilidade, longa duração e baixo consumo de energia, os switches HPE OfficeConnect série 1405 são ideais para empresas preocupadas com o custo total de propriedade e sua segurança.





# HP 1405 Switch Series

Installation and Getting Started Guide

HP 1405-5 Switch (J9791A)  
HP 1405-5G Switch (J9792A)  
HP 1405-8 Switch (J9793A)  
HP 1405-8G Switch (J9794A)



---

# HP 1405 Switch Series

---

Installation and Getting Started Guide

### Manual Part Number

5998-3081  
May 2012

### Applicable Products

HP 1405-5 Switch	(J9791A)
HP 1405-5G Switch	(J9792A)
HP 1405-8 Switch	(J9793A)
HP 1405-8G Switch	(J9794A)

### Disclaimer

HEWLETT-PACKARD COMPANY MAKES NO WARRANTY OF ANY KIND WITH REGARD TO THIS MATERIAL, INCLUDING, BUT NOT LIMITED TO, THE IMPLIED WARRANTIES OF MERCHANTABILITY AND FITNESS FOR A PARTICULAR PURPOSE. Hewlett-Packard shall not be liable for errors contained herein or for incidental or consequential damages in connection with the furnishing, performance, or use of this material.

The information contained herein is subject to change without notice. The only warranties for HP products and services are set forth in the express warranty statements accompanying such products and services. Nothing herein should be construed as constituting an additional warranty. HP shall not be liable for technical or editorial errors or omissions contained herein.

Hewlett-Packard assumes no responsibility for the use or reliability of its software on equipment that is not furnished by Hewlett-Packard.

### Warranty

For the latest license and warranty information, visit [www.hp.com/networking/support](http://www.hp.com/networking/support).

A copy of the specific warranty terms applicable to your Hewlett-Packard products and replacement parts can be obtained from your HP Sales and Service Office or authorized dealer.

---

### Safety

Before installing and operating these products, please read the “[Installation Precautions](#)” in chapter 2, “[Installing the Switch](#)”, and the safety statements in the General Safety and Regulatory Information booklet included with the product.

---

---

# Contents

## 1 Introducing the Switch

Front of the Switch .....	1-2
Network Ports .....	1-3
LEDs .....	1-3
Back of the Switch .....	1-4
Power Connector .....	1-4
Switch Features .....	1-5

## 2 Installing the Switch

Included Parts .....	2-1
Installation Precautions .....	2-3
Installation Procedures .....	2-4
1. Prepare the Installation Site .....	2-5
2. Verify the Switch Passes Self Test .....	2-6
LED Behavior .....	2-8
3. Mount the Switch .....	2-8
Wall Mounting .....	2-8
Horizontal Surface Mounting .....	2-9
4. Connect the Switch to a Power Source .....	2-11
5. Connect the Network Cables .....	2-12
Using the RJ-45 Connectors .....	2-12
Sample Network Topologies .....	2-13

## 3 Troubleshooting

Basic Troubleshooting Tips .....	3-1
Diagnosing with the LEDs .....	3-3
LED patterns for General Switch Troubleshooting .....	3-3
Hardware Diagnostic Tests .....	3-5
Testing the Switch by Resetting It .....	3-5
Testing Twisted-Pair Cabling .....	3-5

Testing End-to-End Network Communications .....	3-5
HP Customer Support Services .....	3-6
Before Calling Support .....	3-6

## **A Specifications**

Switch Specifications .....	A-1
Physical .....	A-1
Electrical .....	A-1
Environmental .....	A-2
Acoustics .....	A-2
Safety .....	A-2
Cabling and Technology Information Specifications .....	A-3
Twisted-Pair Cable/Connector Pin-Outs .....	A-4
Straight-through Twisted-Pair Cable for 10 Mbps or 100 Mbps Network Connections .....	A-6
Cable Diagram .....	A-6
Pin Assignments .....	A-6
Crossover Twisted-Pair Cable for 10 Mbps or 100 Mbps Network Connection .....	A-7
Cable Diagram .....	A-7
Pin Assignments .....	A-7
Straight-Through Twisted-Pair Cable for 1000 Mbps Network Connections .....	A-8
Cable Diagram .....	A-8
Pin Assignments .....	A-8

## **B EMC Regulatory Statements**

Regulatory Statements .....	B-1
-----------------------------	-----

## **Index**

# Introducing the Switch

---

The HP 1405-5, 1405-5G, 1405-8, and 1405-8G Switches are multiport unmanaged switches that can be used to build high-performance switched workgroup networks. These switches are store-and-forward devices that offer low latency for high-speed networking.

**HP 1405-5 Switch (J9791A)**

**HP 1405-5G Switch (J9792A)**

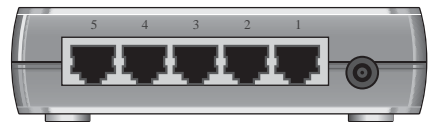

**HP 1405-8 Switch (J9793A)**

**HP 1405-8G Switch (J9794A)**

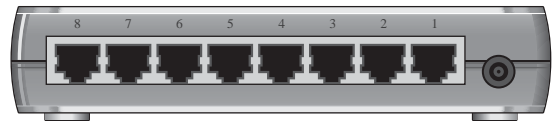

Throughout this manual, these switches will be referred to as the 1405-5 Switch, 1405-5G Switch, 1405-8 Switch, and 1405-8G Switch.

- The 1405-5 Switch has 5 auto-sensing 10/100Base-TX RJ-45 ports.
- The 1405-5G Switch has 5 auto-sensing 10/100/1000Base-T RJ-45 ports.
- The 1405-8 Switch has 8 auto-sensing 10/100Base-TX RJ-45 ports.
- The 1405-8G Switch has 8 auto-sensing 10/100/1000Base-T RJ-45 ports.

These switches can be directly connected to computers, printers, and servers to provide dedicated bandwidth to those devices, and you can build a switched network infrastructure by connecting the switch to other switches or routers.



## Front of the Switch

**HP 1405-5 Switch (J9791A)**  
**HP 1405-5G Switch (J9792A)**

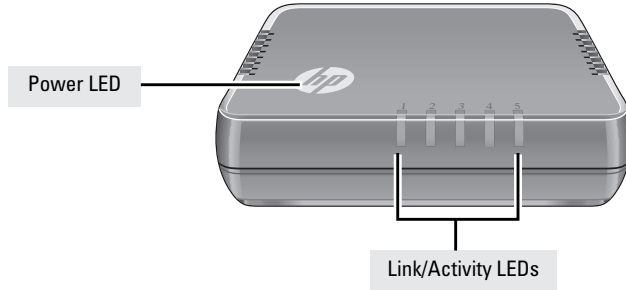

**HP 1405-8 Switch (J9793A)**  
**HP 1405-8G Switch (J9794A)**

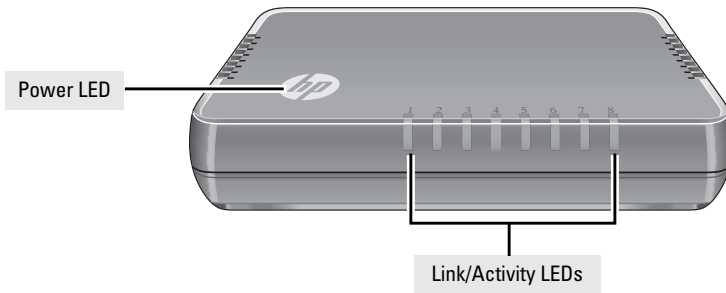

## Network Ports

The network ports support “Auto-MDIX” feature, which means that you can use either straight-through or crossover twisted-pair cables to connect any network devices to the switch.

- 5 or 8 auto-sensing 10/100Base-TX ports.
- 5 or 8 auto-sensing 10/100/1000Base-T ports (for 1405-5G and 1405-8G only).

## LEDs

The front panels of the switches provide status LEDs for system monitoring. [Table 1-1](#) details the functions of the LED indicators.

**Table 1-1. Switch Status LEDs**

Switch LEDs	State	Meaning
HP Power LED (white)	On	The switch is properly receiving power.
	Off	No power connection. The switch is NOT receiving power.
<b>Port LEDs</b>		
Link/Act (blue)	On	The port is enabled and receiving a link indication from the connected device.
	Off	One of these condition exists: <ul style="list-style-type: none"> <li>• no active network cable is connected to the port</li> <li>• the port is not receiving link beat or sufficient light</li> </ul>
	Flashing <sup>1</sup>	Indicates that there is network activity on the port.
<sup>1</sup> The flashing behavior is an on/off cycle once every 0.083 seconds approximately.		

## Back of the Switch

**HP 1405-5 Switch (J9791A)**

**HP 1405-5G Switch (J9792A)**

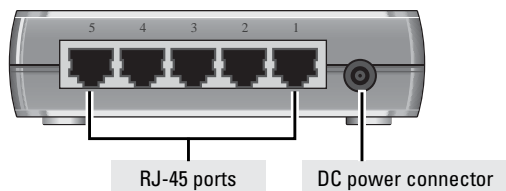

**HP 1405-8 Switch (J9793A)**

**HP 1405-8G Switch (J9794A)**

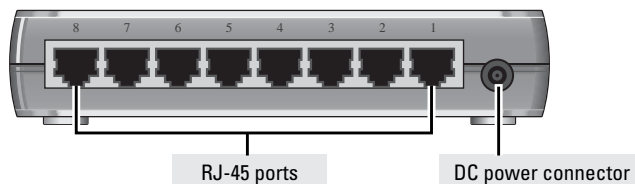

## Power Connector

The switches do not have a power switch. They are powered on when the external AC/DC power adapter is connected to the switch and to a power source. The external AC/DC power adapter supplies 12 volts DC to the switch and automatically adjusts to any AC voltage between 100-240 volts and either 50 or 60 Hz. No voltage range settings are required.

## Switch Features

The features of the switches include:

- All 10/100Base-TX and 10/100/1000Base-T RJ-45 ports are auto-sensing and support Auto-MDIX.
- Plug-and-play networking—all ports are enabled—just connect the network cables to active network devices and your switched network is operational.
- Automatically negotiated full-duplex operation for the RJ-45 ports when connected to other auto-negotiating devices.
- The 1405-5G and 1405-8G models comply with IEEE 802.3ab (1000Base-T) standards.
- The network ports support the IEEE 802.3az Energy Efficient Ethernet standard, which reduces power consumption when connected with IEEE-compliant client devices.
- Automatic learning of the hardware addresses in each switch's address forwarding table. Each switch has different MAC address table sizes:
  - 1405-5 Switch and 1405-5G Switch: 2K
  - 1405-8 Switch: 1K
  - 1405-8G Switch: 8K
- The 1405-5G Switch and 1405-8G Switch include support for up to 9216-byte Jumbo frames to improve performance of large data transfers.
- The 1405-5 Switch includes support for up to 2048-byte mini-Jumbo frames to improve performance of large data transfers.
- Support for IEEE 802.1p prioritization Quality of Service (QoS) to deliver data to devices based on the priority and type of traffic.
- Support for EAPoL packet forwarding for 802.1x client authentication.
- Support for BPDU packet forwarding for switch deployment in spanning tree networks.
- Support for Differentiated Services Code Point (DSCP).
- Fanless designed enables quiet operation for deployment in open spaces.

# Installing the Switch

---

This chapter provides installation information for the 1405-5 Switch, 1405-5G Switch, 1405-8 Switch, and 1405-8G Switch.

---

## Included Parts

The switches have the following components:

- Documentation kit
- Wall/table-mount accessory kit:
  - Four rubber feet
  - Two wall-mount tapping screws
  - Two wall-mount anchors

■ External AC/DC power adapters and power cords, one of the following:

• **Universal External AC/DC Power Adapter**

All countries/regions 5066-1122

**Power cord options for Universal AC/DC Adapter**

Australia/New Zealand 8121-0870

China 8120-8373

Continental Europe/Denmark/  
....Switzerland/Israel/Vietnam/Indonesia 8120-6314

India 8121-0702

Japan 8120-6316

South Africa 8120-6317

Taiwan 8121-0963

Thailand 8121-0664

United Kingdom/United Arab Emirates (UAE)/  
....Hong Kong/Singapore/Malaysia 8120-8699

United States/Canada/Mexico 8120-6313

Brazil 8121-1081

Argentina 8120-8367

Chile 8121-0514

• **Wall Plug-in External AC/DC Power Adapter  
(AC Power cords are not used)**

United States/Canada 5184-5863

Continental Europe/Denmark/  
....Norway/Sweden/Switzerland 5184-5864

---

**Japan Power  
Cord Warning**

---

製品には、同梱された電源コードをお使い下さい。  
同梱された電源コードは、他の製品では使用出来ません。

## Installation Precautions

---

### WARNING

- **Wall-mount the switches with network ports facing up (away from the floor) or down (toward the floor). Do not wall-mount any of the switches with the ventilation ducts facing up or down.**

---

### Cautions

- Use only the AC/DC power adapter supplied with the switch for connection to an AC power source.
  - If your installation requires a different power cord than the one supplied with the switch, ensure the cord is adequately sized for the switch's current requirements. In addition, be sure to use a power cord displaying the mark of the safety agency that defines the regulations for power cords in your country. The mark is your assurance that the power cord can be used safely with the switch. If the supplied power cord does not fit, contact HP networking support.
  - When installing the switch, the AC outlet should be near the switch and should be easily accessible in case the switch must be powered off.
  - Ensure the switch does not overload the power circuits, wiring, and over-current protection. To determine the possibility of overloading the supply circuits, add together the ampere ratings of all devices installed on the same circuit as the switch and compare the total with the rating limit for the circuit. Maximum ampere ratings are usually printed on the devices near the AC power connectors.
  - Do not install the switch in an environment where the operating ambient temperature might exceed 40°C (104°F). This includes a fully-enclosed rack. Ensure the air flow around the sides and back of the switch is not restricted. Leave at least 7.6 cm (3 inches) for cooling.
  - For indoor use only. For safe and reliable operation, do not install the switch or LAN cables outdoors.
-

## Installation Procedures

These steps summarize your switch installation. The rest of this chapter provides details on these steps.

1. **Prepare the installation site (page 2-5).** Make sure the physical environment into which you will be installing the switch is properly prepared, including having the correct network cabling ready to connect to the switch and having an appropriate location for the switch. See [page 2-3](#) for some installation precautions.
2. **Verify the switch passes self test (page 2-6).** Plug the switch into a power source and observe that the LEDs on the switch's front panel indicate correct switch operation.
3. **Mount the switch (page 2-8).** The switches can be mounted on a wall or on a horizontal surface.
4. **Connect power to the switch (page 2-11).** Once the switch is mounted, plug it into the main power source.
5. **Connect the network devices (page 2-12).** Using the appropriate network cables, connect the network devices to the switch ports.

At this point, your switch is fully installed. See the rest of this chapter if you need more detailed information on any of these installation steps.



## 1. Prepare the Installation Site

- **Cabling Infrastructure** - Ensure the cabling infrastructure meets the necessary network specifications. See appendix A, [“Cabling and Technology Information Specifications”](#) for more information:
  
- **Installation Location** - Before installing the switch, plan its location and orientation relative to other devices and equipment:
  - On the back of the switch, leave at least 7.6 cm (3 inches) of space for the twisted-pair cabling.
  - On the back of the switch, leave at least 3.8 cm (1 1/2 inches) of space for the power cord.
  - On the sides of the switch, leave at least 7.6 cm (3 inches) for cooling.

## 2. Verify the Switch Passes Self Test

Before mounting the switch in its network location, you should first verify it is working properly by plugging it into a power source and verifying it passes its self test.

1. Connect the AC/DC adapter's power cord to the power connector on the back of the switch, and then plug the AC/DC power adapter into a nearby properly grounded electrical outlet.

---

### Note

The switches are shipped with one of two types of AC/DC power adapter; either the universal AC/DC adapter with an AC power cord, or the wall plug-in AC/DC adapter (without an AC power cord).

---

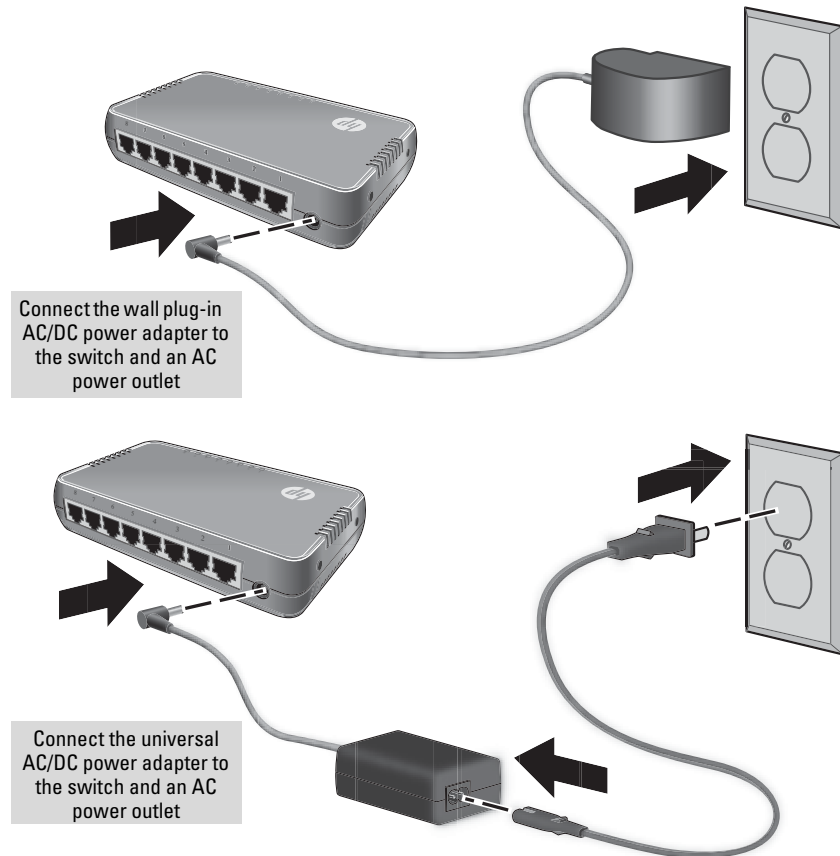

Figure 2-1. Connecting the switch power adapter

---

**Note**

The switches do not have a power switch. They are powered on when the external AC/DC power adapter is connected to the switch and the adapter power cord to a power source. The external AC/DC power adapter automatically adjusts to any voltage between 100-240 volts and either 50 or 60 Hz.

If your installation requires a different power cord than the one supplied with the switch, be sure the cord is adequately sized for the switch's current requirements. In addition, be sure to use a power cord displaying the mark of the safety agency that defines the regulations for power cords in your country. The mark is your assurance that the power cord can be used safely with the switch. If the supplied power cord does not fit, contact HP networking support.

---

**Caution**

Use only the AC/DC power adapter and power cord, supplied with the switch. Use of other adapters or power cords, including those that came with other HP networking products, may result in damage to the equipment.

---

2. Check the LEDs on the switch as described below.

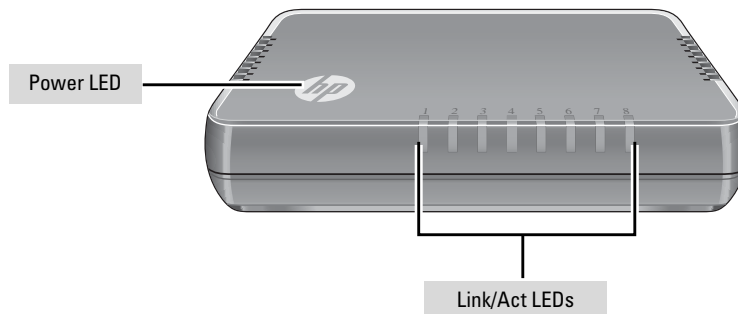

**Figure 2-2. Checking the LEDs**

When the switch is powered on, the switch is initialized. Initialization takes approximately one or two seconds, depending on the switch model.

## LED Behavior

### After Initialization:

- The **Power** LED remains on.
- The port **Link/Act** LEDs on the front of the switch go into their normal operational mode:
  - If the ports are connected to active network devices, the **Link/Act** LEDs stay on or may be blinking to indicate port activity.
  - If the ports are not connected to active network devices, the **Link/Act** LEDs will stay off.

If the LED display is different than what is described above, the self test has not completed correctly. Refer to chapter 4, “[Troubleshooting](#)” for diagnostic help.

## 3. Mount the Switch

After the switch passes self test, it is ready to be mounted in a stable location. The switch can be mounted in these ways:

- on a horizontal surface
- on a wall

### Wall Mounting

You can mount the switch on a wall. A special kit for wall mounting is included with the switch.

---

**Caution**

---

The switch should be mounted only to a wall or wood surface that is at least 1/2-inch (12.7 mm) plywood or its equivalent.

1. In the required location, mark the position for the mounting screws.
2. Use a Phillips #2 (cross-head) screwdriver and two of the included  $\varnothing 3.5\text{mm}$  tapping screws to mount the switch on the wall or wood surface.

Screws and wall anchors are included in the accessory kit for use with plastered brick or concrete walls.

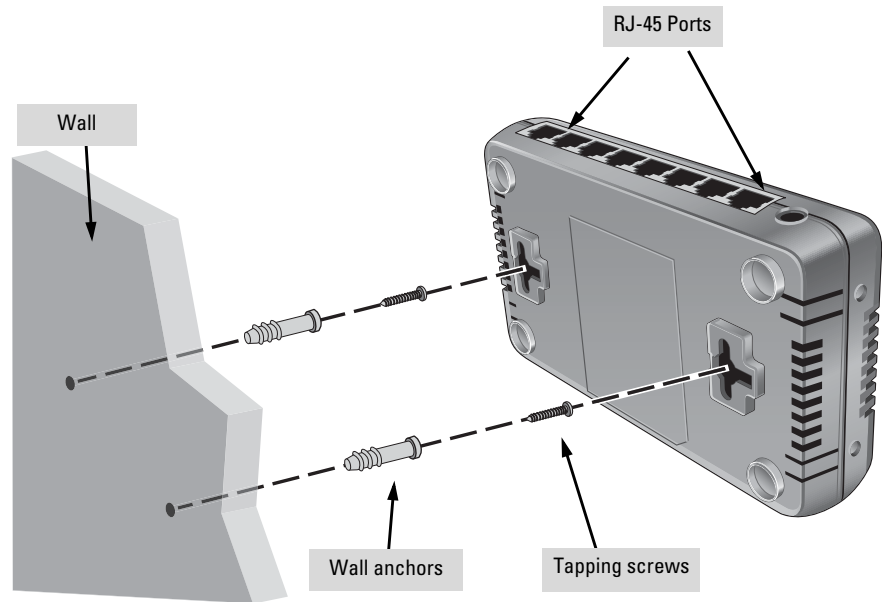

**Figure 2-3. Wall mounting the switch**

### Horizontal Surface Mounting

Place the switch on a table or other horizontal surface. The switch comes with rubber feet in the accessory kit that can be used to help keep the switch from sliding on the surface.

Attach the rubber feet to the four corners on the bottom of the switch within the embossed angled lines. Use a sturdy surface in an uncluttered area. You may want to secure the networking cables and switch power cord to the table leg or other part of the surface structure to help prevent tripping over the cords.

---

**Caution**

---

Ensure the air flow is not restricted around the switch.

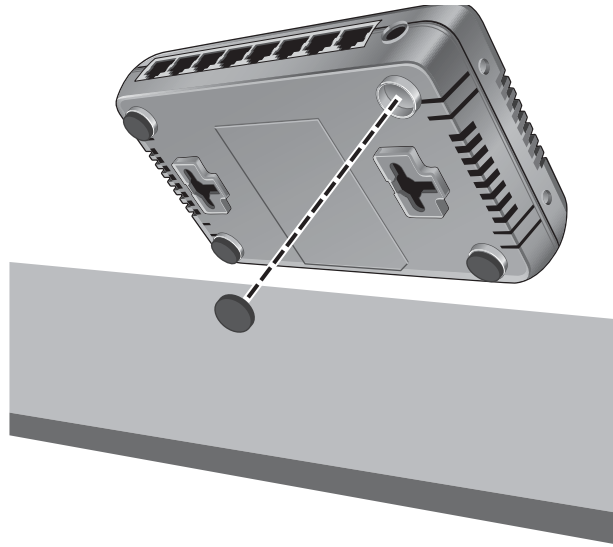

**Figure 2-4. Horizontal surface mounting**

## 4. Connect the Switch to a Power Source

1. Plug the AC/DC adapter's power cord into the switch, and then plug the AC/DC power adapter into a nearby AC power source.

---

### Note

The switches are shipped with one of two types of AC/DC power adapter; either the universal AC/DC adapter with an AC power cord, or the wall plug-in AC/DC adapter (without an AC power cord).

---

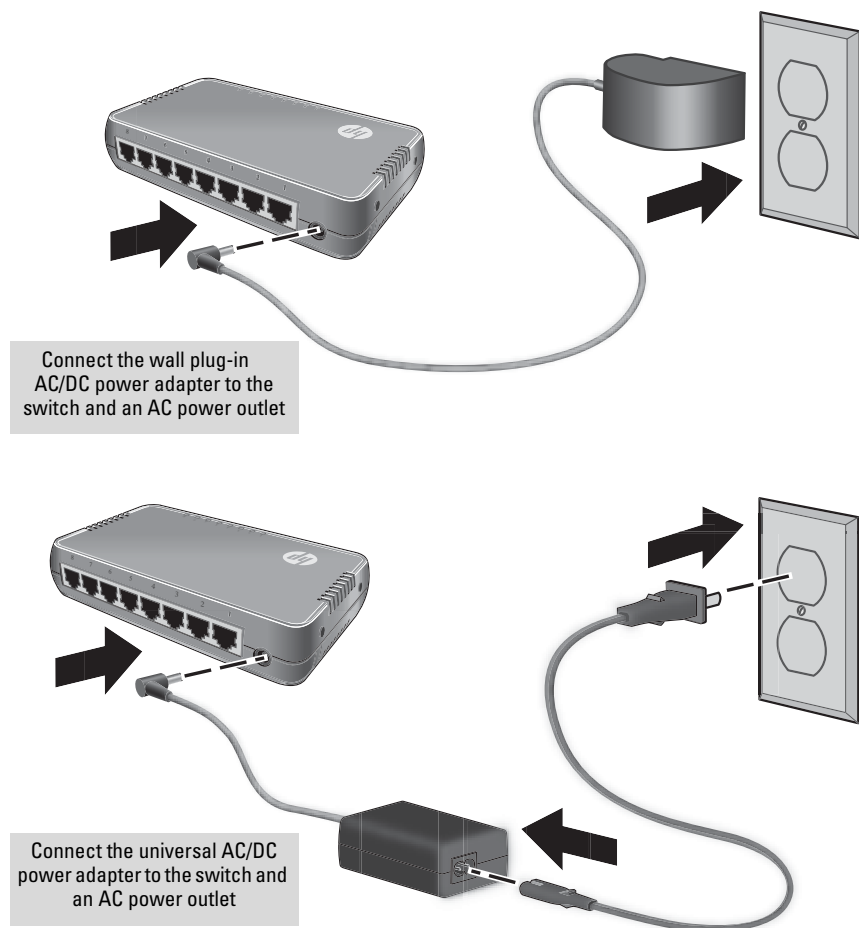

**Figure 2-5. Connecting power to the switch**

2. Re-check the LEDs during self test. See [“LED Behavior”](#) on page 2-8.

---

**Caution**

---

Use only the AC/DC power adapter and power cord (if applicable), supplied with the switch. Use of other adapters or power cords, including those that came with other HP networking products, may result in damage to the equipment.

## 5. Connect the Network Cables

Connect the network cables, described under “Cabling Infrastructure” (page 2-5), from the network devices or your patch panels to the fixed RJ-45 ports on the switch.

### Using the RJ-45 Connectors

To connect:  
Push the RJ-45 plug into the RJ-45 port until the tab on the plug clicks into place. When power is on for the switch and for the connected device, the **Link/Act** LED for the port should light to confirm a powered-on device (for example, an end node) is at the other end of the cable.

If the **Link/Act** LED does not go on when the network cable is connected to the port, see “[Diagnosing with the LEDs](#)” in chapter 4, “Troubleshooting”.

To disconnect:  
Press the small tab on the plug and pull the plug out of the port.

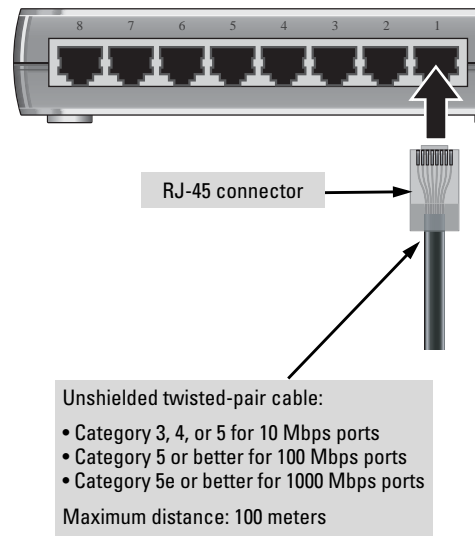
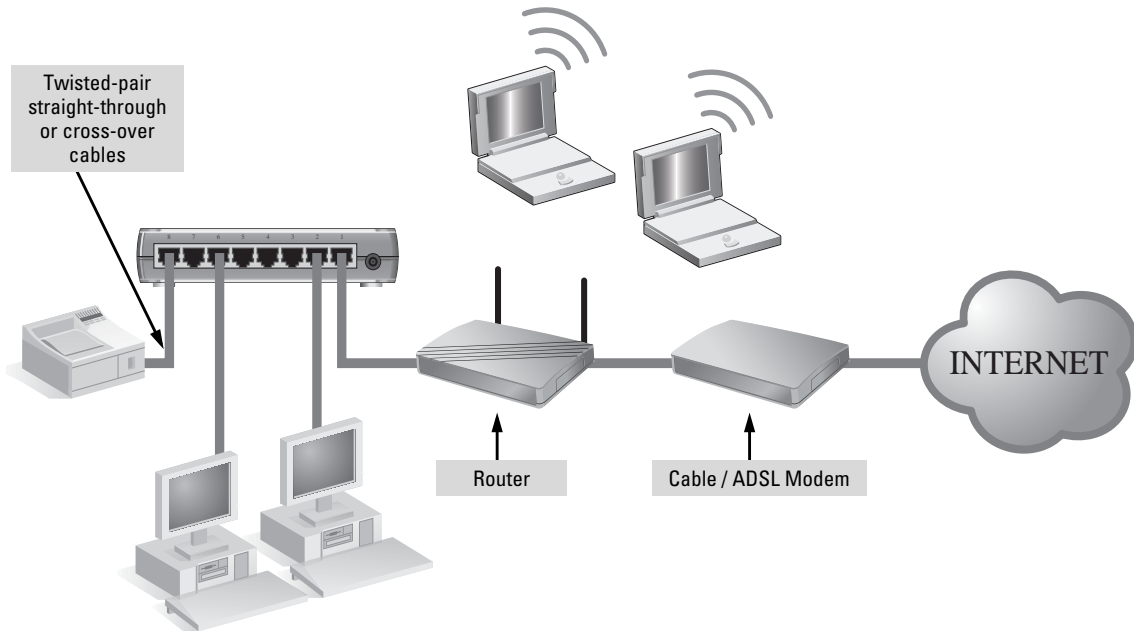

**Figure 2-6. Connecting network cables**



## Sample Network Topologies

This section shows a few sample network topologies for implementing the switches.



**Figure 2-7. Basic configuration**

The switches are designed to be used as desktop switches to which end nodes, printers and other peripherals are directly connected, as shown in the above illustration.

Because the switches have the Auto-MDIX feature, the connections between the switches and end nodes or servers can be through category 5 straight-through or cross-over twisted-pair cable. Category 3 or 4 cable can also be used if the connection is 10 Mbps only.

# Troubleshooting

---

This chapter describes how to troubleshoot your 1405-5 Switch, 1405-5G Switch, 1405-8 Switch, and 1405-8G Switch. This document describes troubleshooting from a hardware perspective.

This chapter describes the following:

- basic troubleshooting tips ([page 3-1](#))
  - diagnosing with the LEDs ([page 3-3](#))
  - hardware diagnostic tests ([page 3-5](#))
  - HP Customer Support Services ([page 3-6](#))
- 

## Basic Troubleshooting Tips

Most problems are caused by the following situations. Check for these items first when starting your troubleshooting:

- **Connecting to devices that have a fixed full-duplex configuration.**  
The RJ-45 ports are configured as “Auto”. That is, when connecting to attached devices, the switch operates in one of two ways to determine the link speed and the communication mode (half duplex or full duplex):
  - If the connected device is also configured to Auto, the switch will automatically negotiate both link speed and communication mode.
  - If the connected device has a fixed configuration, for example 100 Mbps, at half or full duplex, the switch will automatically sense the link speed, but will default to a communication mode of half duplex.

---

### Caution

Because the switches behave in this way (*in compliance with the IEEE 802.3 standard*), if a device connected to the switch has a fixed configuration at full duplex, the device will not connect correctly to the switch. The result will be high error rates and very inefficient communications between the switch and the device.

Ensure all devices connected to the switches are configured to auto negotiate, or are configured to connect at half duplex (all hubs are configured this way, for example).

---

- **Faulty or loose cables.** Look for loose or obviously faulty connections. If the cables appear to be OK, make sure the connections are snug. If that does not correct the problem, try a different cable.
- **Non-standard cables.** Non-standard and miswired cables may cause network collisions and other network problems, and can seriously impair network performance. Use a new correctly-wired cable or compare your cable to the cable in appendix A, “**Cabling and Technology Information Specifications**” for pinouts and correct cable wiring. A category 5 cable tester is a recommended tool for every 100Base-TX and 1000Base-T network installation.
- **Improper Network Topologies.** It is important to make sure you have a valid network topology. Common topology faults include excessive cable length and excessive repeater delays between end nodes. If you have network problems after recent changes to the network, change back to the previous topology. If you no longer experience the problems, the new topology is probably at fault.

In addition, you should make sure that your network topology contains ***no data path loops***. Between any two end nodes, there should be only one active cabling path at any time. Data path loops will cause broadcast storms that will severely impact your network performance.

---

## Diagnosing with the LEDs

Table 3-1 shows LED patterns on the switch that indicate problem conditions for general switch operation troubleshooting.

### LED patterns for General Switch Troubleshooting

1. Check in the table for the LED pattern you see on your switch.
2. Refer to the corresponding diagnostic tip on the next few pages.

**Table 3-1. LED Error Indicators**

LED Pattern Indicating Problems		Diagnostic Tips
Power	Port Link/Act LED	
Off with power cord plugged in	See Note 1	❶
On	Off with cable connected	❷

<sup>1</sup> This LED is not important for the diagnosis.

## Diagnostic Tips:

Tip	Problem	Solution
❶	The switch is not plugged into an active AC power source, or the switch's power supply may have failed.	<ol style="list-style-type: none"><li>1. Verify the power cord is plugged into an active power source and to the switch. Make sure these connections are snug.</li><li>2. Try power cycling the switch by unplugging and plugging the power cord back in.</li><li>3. If the Power LED is still not on, verify the AC power source works by plugging another device into the outlet. Or try plugging the switch into a different outlet or try a different power cord.</li></ol> <p>If the power source and power cord are OK and this condition persists, the switch power supply may have failed. Call your HP networking authorized network reseller, or use the electronic support services from HP to get assistance. For software license, warranty, and support information, visit <a href="http://www.hp.com/networking/support">www.hp.com/networking/support</a>.</p>
❷	The network connection is not working properly.	<p>Try the following procedures:</p> <ul style="list-style-type: none"><li>• For the indicated port, verify that both ends of the cabling, at the switch and the connected device, are connected properly.</li><li>• Verify the connected device and switch are both powered <i>on</i> and operating correctly.</li><li>• Verify you have used the correct cable type for the connection:<ul style="list-style-type: none"><li>– For twisted-pair connections to the fixed 10/100/1000 ports, either straight-through or cross-over cables can be used because of the switch's "Auto-MDIX" feature and the Auto MDI/MDI-X feature of the 10/100/1000-T port.</li></ul></li><li>• For 1000Base-T connections, verify the network cabling complies with the IEEE 802.3ab standard. The cable should be installed according to the ANSI/TIA/EIA-568-A-5 specifications. Cable testing should comply with the stated limitations for Attenuation, Near-End Crosstalk, Far-End Crosstalk, Equal-Level Far-End Crosstalk (ELFEXT), Multiple Disturber ELFEXT, and Return Loss.<p>The cable verification process must include all patch cables from any end devices, including the switch, to any patch panels in the cabling path.</p></li><li>• Verify the switch port configuration of the attached device. All switch ports are configured as "Auto", so ports on the attached device also <b>MUST</b> be configured as "Auto". Depending on the port type, twisted-pair or fiber-optic, if the configurations do not match, the results could be a very unreliable connection, or no link at all.</li><li>• If the other procedures don't resolve the problem, try using a different port or a different cable.</li></ul>

## Hardware Diagnostic Tests

### Testing the Switch by Resetting It

If you believe the switch is not operating correctly, you can reset the switch to test its circuitry and operating code. To perform a reset, power cycle the switch; unplug the power cord, wait 2 seconds, then reconnect power.

Power cycling the switch causes the switch to perform its power-on self test.

### Testing Twisted-Pair Cabling

Network cables that fail to provide a link or provide an unreliable link between the switch and the connected network device may not be compatible with the IEEE 802.3 Type 10Base-T, 100Base-TX, or 1000Base-T standards. The twisted-pair cables attached to the switch must be compatible with the appropriate standards. To verify your cable is compatible with these standards, use a qualified cable test device.

### Testing End-to-End Network Communications

Both the switch and the cabling can be tested by running an end-to-end communications test—a test that sends known data from one network device to another through the switch. For example, if you have two PCs on the network that have LAN adapters between which you can run a link-level test or Ping test through the switch, you can use this test to verify that the entire communication path between the two PCs is functioning correctly. See your LAN adapter documentation for more information on running a link test or Ping test.

## HP Customer Support Services

If you are still having trouble with your switch, Hewlett-Packard offers support 24 hours a day, seven days a week through the use of a number of automated electronic services. The HP Web site, [www.hp.com/networking/support](http://www.hp.com/networking/support) also provides up-to-date support information.

Additionally, your HP-authorized network reseller can provide you with assistance, both with services that they offer and with services offered by HP.

### Before Calling Support

Before calling your networking dealer or HP Support, to make the support process most efficient, you first should retrieve the following information:

<b>Information Item</b>	<b>Information Location</b>
• Product identification	On the switch
• Copy of your network topology map, including network addresses assigned to the relevant devices	Your network records

# Specifications

---

## Switch Specifications

### Physical

	<b>Width</b>	<b>Depth</b>	<b>Height</b>	<b>Weight</b>
1405-5 Switch (J9791A)	11.5 cm (4.53 in)	9.15 cm (3.6 in)	3.35 cm (1.32 in)	0.18 kg (0.4lbs)
1405-5G Switch (J9792A)	11.5 cm (4.53 in)	9.15 cm (3.6 in)	3.35 cm (1.32 in)	0.18 kg (0.4 lbs)
1405-8 Switch (J9793A)	15.5 cm (6.10 in)	9.15 cm (3.6 in)	3.35 cm (1.32 in)	0.23 kg (0.5 lbs)
1405-8G Switch (J9794A)	15.5 cm (6.10 in)	9.15 cm (3.6 in)	3.35 cm (1.32 in)	0.23 kg (0.5 lbs)

### Electrical

	<b>AC Voltage</b>	<b>AC Input</b>	<b>Maximum Output Current</b>
15W Inline External Adapter (P/N: 5066-1122)	100-240 volts	50-60 Hz	1.25A
13W Wall-Plug External Adapter (P/Ns: 5184-5863 and 5184-5864)	100-240 volts	50-60 Hz	1.085A

	<b>DC Voltage</b>	<b>DC Maximum Current</b>
1405-5 Switch (J9791A)	12 volts	0.15A
1405-5G Switch (J9792A)	12 volts	0.17A
1405-8 Switch (J9793A)	12 volts	0.16A
1405-8G Switch (J9794A)	12 volts	0.33A



## Environmental

	<b>Operating</b>	<b>Non-Operating</b>
<b>Temperature</b>	0°C to 40°C (32°F to 104°F)	-40°C to 70°C (-40°F to 158°F)
<b>Relative humidity (non-condensing)</b>	15% to 95% at 40°C (104°F)	15% to 90% at 65°C (149°F)
<b>Maximum altitude</b>	3048 m (10,000 ft)*	3048 m (10,000 ft)

\* The operating maximum altitude should not exceed that of any accessory being connected to any switch.

## Acoustics

No fans.

## Safety

- EN 60950-1:2006 ; IEC 60950-1:2005
- CSA-C22.2 No. 60950/UL 60950-2

# Cabling and Technology Information Specifications

**Table A-1. Cabling Specifications**

<b>Twisted-pair copper</b>	10 Mbps Operation	Category 3, 4 or 5, 100-ohm unshielded twisted-pair (UTP) or shielded twisted-pair (STP) cable, complying with IEEE 802.3 10BASE-T specifications.
	100 Mbps Operation	Category 5, 100-ohm UTP or STP cable, complying with IEEE 802.3u 100BASE-TX specifications.
	1000 Mbps Operation	Category 5, 100-ohm 4-pair UTP or STP cable, complying with IEEE 802.3ab 1000BASE-T specifications—Category 5e or better is recommended. See note on 1000BASE-T Cable Requirements below.

**Note on 1000BASE-T Cable Requirements.** The Category 5 networking cables that work for 100BASE-TX connections should also work for 1000BASE-T, as long as all four-pairs are connected. But, for the most robust connections, you should use cabling that complies with the Category 5e specifications, as described in Addendum 5 to the TIA-568-A standard (ANSI/TIA/EIA-568-A-5).

Because of the increased speed provided by 1000BASE-T (Gigabit-T), network cable quality is more important than for either 10BASE-T or 100BASE-TX. Cabling plants being used to carry 1000BASE-T networking must comply with the IEEE 802.3ab standards. In particular, the cabling must pass tests for Attenuation, Near-End Crosstalk (NEXT), and Far-End Crosstalk (FEXT). Additionally, unlike the cables for 100BASE-TX, the 1000BASE-T cables must pass tests for Equal-Level Far-End Crosstalk (ELFEXT) and Return Loss.

When testing your cabling, be sure to include the patch cables that connect the switch and other end devices to the patch panels on your site. The patch cables are frequently overlooked when testing cable and they must also comply with the cabling standards.

## Twisted-Pair Cable/Connector Pin-Outs

**The Auto-MDIX Feature:** In the default configuration, “Auto”, the fixed 10/100/1000Base-T ports on the switches all automatically detect the type of port on the connected device and operate as either an MDI or MDI-X port, whichever is appropriate. So for any connection, a straight-through twisted-pair cable can be used—you no longer have to use crossover cables, although crossover cables can also be used for any of the connections. (The 10/100/1000-T ports support the IEEE 802.3ab standard, which includes the “Auto-MDIX” feature.)

If you connect a switch twisted-pair port to another switch or hub, which typically have MDI-X ports, the switch port automatically operates as an MDI port. If you connect it to an end node, such as a server or PC, which typically have MDI ports, the switch port operates as an MDI-X port. In all cases, you can use standard straight-through cables or crossover cables.

If you happen to use a correctly wired crossover cable, though, the switch will still be able to automatically detect the MDI/MDI-X operation and link correctly to the connected device.

---

### Note

**Using Fixed Configurations.** If the port configuration is changed to any of the fixed configurations though, for example 100 Mbps/full duplex, the port operates as MDI-X only and the correct cable type must be used: for connections to MDI ports, such as end nodes, use a straight-through cable; for connections to MDI-X ports, such as on hubs and other switches, use a crossover cable.

### Other Wiring Rules:

- All twisted-pair wires used for 10 Mbps, and 100 Mbps operation must be twisted through the entire length of the cable. The wiring sequence must conform to EIA/TIA 568-B (not USOC). See “Twisted-Pair Cable Pin Assignments” later in this appendix for a listing of the signals used on each pin.
- For 1000Base-T connections, all four pairs of wires in the cable must be available for data transmission.
- For 10 Mbps connections to the ports, you can use Category 3, 4, or 5 unshielded twisted-pair cable, as supported by the IEEE 802.3 Type 10Base-T standard.

- For 100 Mbps connections to the ports, use 100-ohm Category 5 UTP or STP cable only, as supported by the IEEE 802.3u Type 100Base-TX standard.
- For 1000 Mbps connections, 100-ohm Category 5e or better cabling is recommended.

## Straight-through Twisted-Pair Cable for 10 Mbps or 100 Mbps Network Connections

Because of the Auto-MDIX operation of the 10/100 ports on the switch, for all network connections, to PCs, servers or other end nodes, or to hubs or other switches, you can use straight-through cables.

If any of these ports are given a fixed configuration, for example 100 Mbps/ Full Duplex, the ports operate as MDI-X ports, and straight-through cables must be then used for connections to PC NICs and other MDI ports.

### Cable Diagram

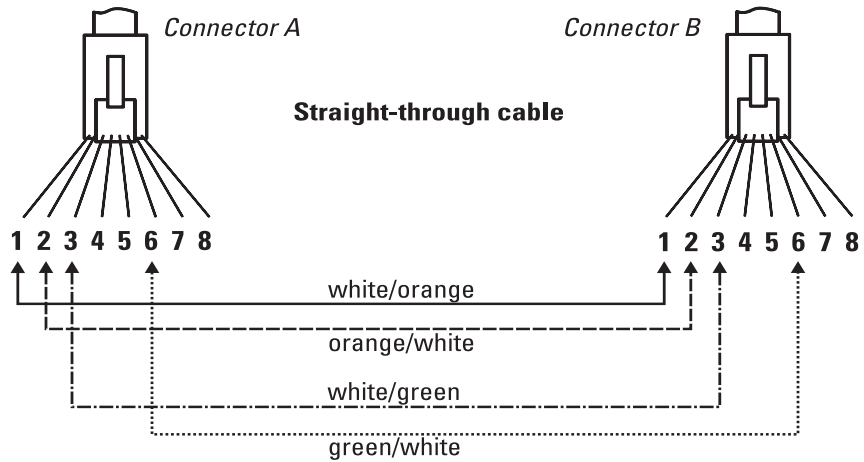

### Note

Pins 1 and 2 on connector “A” *must* be wired as a twisted pair to pins 1 and 2 on connector “B”.  
 Pins 3 and 6 on connector “A” *must* be wired as a twisted pair to pins 3 and 6 on connector “B”.  
 Pins 4, 5, 7, and 8 are not used in this application, although they may be wired in the cable.

### Pin Assignments

Switch End (MDI-X)		Computer, Transceiver, or Other End		
Signal	Pins	Pins	Signal	
receive +	1	←	1	transmit +
receive -	2	←	2	transmit -
transmit +	3	→	3	receive +
transmit -	6	→	6	receive -

## Crossover Twisted-Pair Cable for 10 Mbps or 100 Mbps Network Connection

The Auto-MDIX operation of the 10/100 ports on the switch also allows you to use crossover cables for all network connections, to PCs, servers or other end nodes, or to hubs or other switches.

If any of these ports are given a fixed configuration, for example 100 Mbps/ Full Duplex, the ports operate as MDI-X ports, and crossover cables *must* be then used for connections to hubs or switches or other MDI-X network devices.

### Cable Diagram

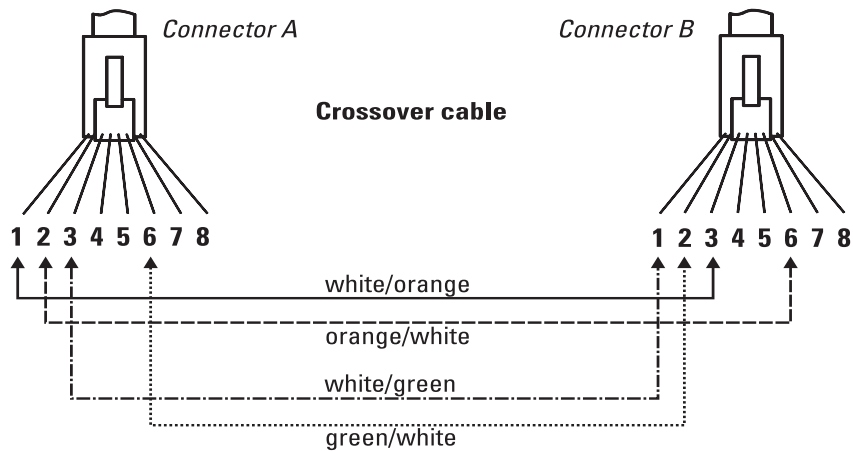

### Note

Pins 1 and 2 on connector “A” *must* be wired as a twisted pair to pins 3 and 6 on connector “B”.

Pins 3 and 6 on connector “A” *must* be wired as a twisted pair to pins 1 and 2 on connector “B”.

Pins 4, 5, 7, and 8 are not used in this application, although they may be wired in the cable.

### Pin Assignments

Switch End (MDI-X)		Hub or Switch Port, or Other MDI-X Port End	
Signal	Pins	Pins	Signal
receive +	1	6	transmit -
receive -	2	3	transmit +
transmit +	3	2	receive -
transmit -	6	1	receive +

## Straight-Through Twisted-Pair Cable for 1000 Mbps Network Connections

1000Base-T connections require that all four pairs of wires be connected.

### Cable Diagram

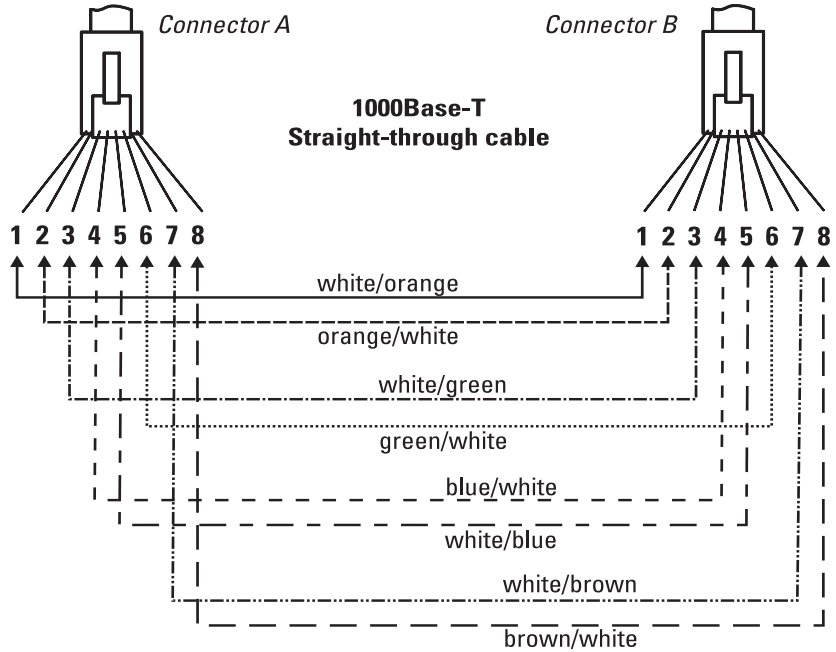

---

### Note

Pins 1 and 2 on connector “A” *must* be wired as a twisted pair to pins 1 and 2 on connector “B”.  
Pins 3 and 6 on connector “A” *must* be wired as a twisted pair to pins 3 and 6 on connector “B”.  
Pins 4 and 5 on connector “A” *must* be wired as a twisted pair to pins 4 and 5 on connector “B”.  
Pins 7 and 8 on connector “A” *must* be wired as a twisted pair to pins 7 and 8 on connector “B”.

---

### Pin Assignments

For 1000Base-T operation, all four pairs of wires are used for both transmit and receive.

# EMC Regulatory Statements

---

## Regulatory Statements

### FCC Class B

This equipment has been tested and found to comply with the limits for a Class B digital device, pursuant to Part 15 of the FCC Rules. These limits are designed to provide reasonable protection against harmful interference in a residential installation. This equipment generates, uses and can radiate radio frequency energy and, if not installed and used in accordance with the instructions, may cause harmful interference to radio communications. However, there is no guarantee that the interference will not occur in a particular installation. If this equipment does cause harmful interference to radio or television reception, which can be determined by turning the equipment off and on, the user is encouraged to try to correct the interference by one or more of the following measures:

- Reorient or relocate the receiving antenna.
- Increase the separation between the equipment and receiver.
- Connect the equipment into an outlet on a circuit different from that of the receiver.
- Consult the dealer or an experienced radio/TV technician for help.



# Index

---

## Numerics

10/100Base-TX ports  
location on switch ... 1-2

## A

AC power connector  
location on back of switch ... 1-4  
acoustic specifications ... A-2  
auto MDI/MDI-X operation ... A-6, A-8  
HP Auto-MDIX feature ... A-4

## B

back of switch  
description ... 1-4  
power connector ... 1-4  
basic troubleshooting tips ... 3-1

## C

cables  
connecting cables to switch ports ... 2-12  
effects of non-standard cables ... 3-2  
infrastructure requirements ... 2-5  
cables, twisted pair  
category 3, 4, 5 ... A-4  
cross-over cable pin-out ... A-7  
MDI-X to MDI connections ... A-6, A-8  
MDI-X to MDI-X connections ... A-7  
pin-outs ... A-6, A-8  
straight-through cable pin-out ... A-6, A-8  
switch-to-computer connection ... A-6, A-8  
switch-to-switch or hub connection ... A-7  
cables, twisted-pair  
HP Auto-MDIX feature ... A-4  
wiring rules ... A-4  
cables, twisted-pair connector pin-outs ... A-4  
cabling infrastructure ... 2-5  
Clear button  
location on switch ... 1-2  
connecting the switch to a power source ... 2-11  
console port  
location on switch ... 1-2

cross-over cable  
pin-out ... A-7

## D

description  
back of switch ... 1-4  
front of switch ... 1-2  
LEDs ... 1-3  
switch ... 1-1  
diagnostic tests ... 3-5  
end-to-end connectivity ... 3-5  
testing the switch only ... 3-5  
testing twisted-pair cabling ... 3-5

## E

electrical specifications, switch ... A-1  
environmental specifications, switch ... A-2

## F

Fault LED  
behavior during self test ... 2-8  
location on switch ... 1-2  
features  
switch ... 1-5  
flashing LEDs  
error indications ... 3-3  
front of switch ... 1-2  
10/100/1000Base-T ports ... 1-2  
10/100Base-TX ports ... 1-2  
description ... 1-2  
LEDs ... 1-3  
network ports ... 1-3  
full-duplex fixed configuration  
effects on network connections ... 3-1

## H

horizontal surface  
mounting switch on ... 2-9  
HP Auto-MDIX  
feature description ... A-4

## I

included parts ... 2-1

installation

connecting the switch to a power source ... 2-11

horizontal surface mounting ... 2-9

location considerations ... 2-5

network cable requirements ... 2-5

precautions ... 2-3

site preparation ... 2-5

wall mounting ... 2-8

## L

LEDs

behavior during self test ... 2-8

descriptions of ... 1-3

error indications ... 3-3

Fault

behavior during self test ... 2-8

location on switch ... 1-2

on switch ... 1-3

Power ... 1-3

behavior during self test ... 2-8

location for the switch, considerations ... 2-5

## M

MDI-X to MDI network cable ... A-6, A-8

MDI-X to MDI-X network cable ... A-7

mini-GBICs

slot, location on switch ... 1-2

mounting the switch

in a rack or cabinet

precautions ... 2-3

on a horizontal surface ... 2-9

on a wall ... 2-8

precautions ... 2-8

## N

network cables

HP Auto-MDIX feature ... A-4

required types ... 2-5

twisted-pair connector pin-outs ... A-4

twisted-pair, wiring rules ... A-4

network devices

connecting to the switch ... 2-12

network ports

connecting to ... 2-12

location on switch ... 1-3

types of ... 1-3

non-standard network cables, effects ... 3-2

## P

parts, included with the switch ... 2-1

physical specifications, switch ... A-1

pin-outs

twisted-pair cables ... A-4

port LEDs

normal operation ... 2-8

ports

10/100Base-TX, location on switch ... 1-4

connecting to ... 2-12

HP Auto-MDIX feature ... A-4

network connections ... 2-12

power connector ... 1-4

Power LED ... 1-3

behavior during self test ... 2-8

behaviors ... 1-3

location on switch ... 1-2

power source

connecting the switch to ... 2-11

precautions

mounting the switch ... 2-3

power requirements ... 2-3

preparing the installation site ... 2-5

## R

rack

mounting precautions ... 2-3

Reset button

location on switch ... 1-2

resetting the switch

troubleshooting procedure ... 3-5

## S

safety and regulatory statements ... B-1

safety specifications ... A-2

self test

Fault LED behavior ... 2-8

LED behavior during ... 2-8

Power LED behavior ... 2-8

- slots for mini-GBICs
  - location on switch ... 1-2
- specifications
  - acoustic ... A-2
  - electrical ... A-1
  - environmental ... A-2
  - physical ... A-1
  - safety ... A-2
- straight-through cable
  - pin-out ... A-6, A-8
- switch
  - connecting to a power source ... 2-11
  - description ... 1-1
  - electrical specifications ... A-1
  - environmental specifications ... A-2
  - features ... 1-5
  - front panel description ... 1-2
  - included parts ... 2-1
  - LED descriptions ... 1-3
  - mounting on a wall ... 2-8
  - mounting on horizontal surface ... 2-9
  - physical specifications ... A-1
- switch operation
  - verifying after installation ... 2-6

## T

- testing
  - diagnostic tests ... 3-5
  - end-to-end communications ... 3-5
  - switch operation ... 3-5
  - twisted-pair cabling ... 3-5
- tips for troubleshooting ... 3-1
- topologies
  - effects of improper topology ... 3-2
  - samples of ... 2-13
- troubleshooting ... 3-1
  - basic tips ... 3-1
  - common network problems ... 3-1
  - connecting to fixed full-duplex devices ... 3-1
  - diagnostic tests ... 3-5
  - effects of improper topology ... 3-2
  - effects of non-standard cables ... 3-2
  - testing end-to-end communications ... 3-5
  - testing the switch ... 3-5
  - testing the twisted-pair cables ... 3-5

- twisted-pair cable
  - cross-over cable pin-out ... A-7
  - pin-outs ... A-4, A-6, A-8
  - straight-through cable pin-out ... A-6, A-8
  - switch-to-computer connection ... A-6, A-8
  - switch-to-switch or hub connection ... A-7
  - testing ... 3-5
- twisted-pair ports
  - HP Auto-MDIX feature ... A-4

## W

- wall
  - mounting switch on ... 2-8
- wiring rules for twisted-pair cables ... A-4



---

Technology for better business outcomes

To learn more, visit [www.hp.com/networking](http://www.hp.com/networking)

© Copyright 2012 Hewlett-Packard Development Company, L.P.

The information contained herein is subject to change without notice. The only warranties for HP products and services are set forth in the express warranty statements accompanying such products and services. Nothing herein should be construed as constituting an additional warranty. HP will not be liable for technical or editorial errors or omissions contained herein.



May 2012

Manual Part Number  
5998-3081