



Notebook HP NoteBook PC

Impressionantemente resistente além de fino e leve, o Notebook HP NoteBook PC capacita os usuários a criar, conectar e colaborar, usando tecnologia de desempenho de classe empresarial que ajuda a mantê-lo produtivo, resistente e eficiente dentro e fora do escritório.





HP 240 Notebook PC

HP 246 Notebook PC

HP 450 Notebook PC

HP 245 Notebook PC

HP 455 Notebook PC

Maintenance and Service Guide

© Copyright 2012, 2013 Hewlett-Packard
Development Company, L.P.

AMD and Radeon are trademarks of
Advanced Micro Devices, Inc. Bluetooth is a
trademark owned by its proprietor and used
by Hewlett-Packard Company under license.
Intel, Celeron, Core, and Pentium are
trademarks of Intel Corporation in the U.S.
and other countries. Microsoft and Windows
are U.S. registered trademarks of Microsoft
Corporation. SD Logo is a trademark of
its proprietor.

The information contained herein is subject
to change without notice. The only
warranties for HP products and services are
set forth in the express warranty statements
accompanying such products and services.
Nothing herein should be construed as
constituting an additional warranty. HP shall
not be liable for technical or editorial errors
or omissions contained herein.

Second Edition: October 2013

First Edition: November 2012

Document Part Number: 747426-001

Safety warning notice

⚠ WARNING! To reduce the possibility of heat-related injuries or of overheating the device, do not place the device directly on your lap or obstruct the device air vents. Use the device only on a hard, flat surface. Do not allow another hard surface, such as an adjoining optional printer, or a soft surface, such as pillows or rugs or clothing, to block airflow. Also, do not allow the AC adapter to contact the skin or a soft surface, such as pillows or rugs or clothing, during operation. The device and the AC adapter comply with the user-accessible surface temperature limits defined by the International Standard for Safety of Information Technology Equipment (IEC 60950).

Table of contents

1 Product description	1
HP 245 and HP 455 models (AMD models)	1
HP 240, HP 450, and HP 246 models (Intel models)	8
2 External component identification	19
Display	19
Front	20
Right side	20
Left side	21
Top	23
TouchPad	23
Lights	24
Buttons	25
Keys	26
Bottom	27
Labels	29
3 Illustrated parts catalog	30
Computer major components	30
Display assembly subcomponents	36
Mass storage devices	38
Plastics Kit	39
Miscellaneous parts	40
Sequential part number listing	41
4 Removal and replacement procedures	48
Preliminary replacement requirements	48
Tools required	48
Service considerations	48
Plastic parts	48
Cables and connectors	48

Drive handling	49
Grounding guidelines	49
Electrostatic discharge damage	49
Packaging and transporting guidelines	51
Component replacement procedures	53
Service tag and PCID label	53
Service tag	53
PCID label	54
Computer feet	55
Battery	56
Display subcomponents (bezel, webcam, panel)	57
WLAN module	64
Memory module	67
Hard drive	70
RTC battery	73
Optical drive	74
Keyboard	76
Top cover	79
Power button board	83
TouchPad button board	85
Speakers	87
USB board	89
Power connector cable	91
Display assembly	93
System board	102
Optical drive cable	107
Fan/heat sink assembly	109
Processor	115
5 Using Setup Utility (BIOS) and System Diagnostics in Windows 8	118
Starting Setup Utility (BIOS)	118
Updating the BIOS	118
Determining the BIOS version	118
Downloading a BIOS update	119
Using System Diagnostics	120
6 Using Setup Utility (BIOS) and System Diagnostics in Windows 7	121
Starting Setup Utility (BIOS)	121
Updating the BIOS	121
Determining the BIOS version	121
Downloading a BIOS update	122

Using System Diagnostics	123
7 Specifications	124
Computer specifications	124
14.0-inch display specifications	125
Hard drive specifications	126
8 Backing up, restoring, and recovering in Windows 8	127
Creating recovery media and backups	128
Creating HP Recovery media	128
Restore and recovery	130
Using Windows Refresh for quick and easy recovery	131
Remove everything and reinstall Windows	131
Recovering using HP Recovery Manager	132
What you need to know	132
Using the HP Recovery partition to recover a minimized image (select models only)	133
Using HP Recovery media to recover	133
Changing the computer boot order	133
Removing the HP Recovery partition	134
9 Backing up, restoring, and recovering in Windows 7	135
Creating backups	135
Creating recovery media to recover the original system	135
What you need to know	135
Creating the recovery media	136
Creating system restore points	136
What you need to know	136
Creating a system restore point	137
Backing up system and personal information	137
Tips for a successful backup	137
What you need to know	137
Creating a backup using Windows Backup and Restore	138
Restore and recovery	139
Restoring to a previous system restore point	139
Restoring specific files	139
Restoring specific files using Windows Backup and Restore	139
Recovering the original system using HP Recovery Manager	139
What you need to know	140
Recovering using HP Recovery partition (select models only)	140

Recovering using the recovery media	141
Changing the computer boot order	141
10 Power cord set requirements	142
Requirements for all countries	142
Requirements for specific countries and regions	143
11 Recycling	145
Battery	145
Display	145
Index	151

1 Product description

The tables in the following sections provide details about HP 245, HP 455, HP 240, HP 450, and HP 246 models.

HP 245 and HP 455 models (AMD models)

Category	Description	HP 245 (AMD)	HP 455 (AMD)	HP 455 (Elcot/Kenya)
Product name	HP 245 Notebook PC	√		
	HP 455 Notebook PC		√	√
Processors	AMD E2-2000 1.75-GHz processor (1333-MHz memory speed, dual core, 18 W)	√		
	AMD E2-1800 1.70-GHz processor (1333-MHz memory speed, dual core, 18 W)	√		
	NOTE: This processor is not available on computer models equipped with Windows 7 Starter 32 operating system.			
	AMD E1-2500 1.40-GHz processor (1066-MHz memory speed, dual core, 15 W)			√
	AMD E1-1500 1.48-GHz processor (1066-MHz memory speed, dual core, 18 W)	√		
	AMD E1-1200 1.40-GHz processor (1066-MHz memory speed, dual core, 18 W)	√	√	
	NOTE: This processor is not available on computer models equipped with Windows 7 Starter 32 operating system.			
	AMD E300 1.30-GHz processor (1066-MHz memory speed, 1.0-MB L2 cache, dual core, 18 W)	√	√	
	NOTE: This processor is not available on computer models equipped with Windows 7 Starter 32 operating system.			
AMD A6-5200 2.00-GHz processor (1066-MHz memory speed, dual core, 25 W)	√			
AMD A4-5000 1.50-GHz processor (1066-MHz memory speed, dual core, 15 W)	√			

Category	Description	HP 245 (AMD)	HP 455 (AMD)	HP 455 (Elcot/Kenya)
	AMD A4-3330MX 2.30-GHz processor (1333-MHz memory speed, dual core, 45 W)			√
	AMD A60M 1.40-GHz processor (1066-MHz memory speed, dual core, 18 W)			
Chipset	AMD A68M fusion controller hub (FCH) NOTE: (E2-1800/E1-1200/E2-2000/E1-1500/E300)	√	√	
	AMD A60M FCH			√
	Integrated SOC FCH NOTE: (A6-5200/A4-5000)	√		√
Graphics	AMD Radeon HD 8400 Graphics (on computer models equipped with an AMD A6-5200 processor)	√		
	AMD Radeon HD 8330 Graphics (on computer models equipped with an AMD A4-5000 processor)	√		
	AMD Radeon HD 8240 Graphics (on computer models equipped with an AMD E1-2500 processor)			√
	AMD Radeon HD 7340 Graphics (on computer models equipped with an AMD E2-1800 processor; supports DirectX 11)	√		
	AMD Radeon HD 7310 Graphics (on computer models equipped with an AMD E1-1200 processor)	√	√	√
	AMD Radeon HD 6310 Discrete-Class Graphics (on computer models equipped with an AMD E300 processor; supports DirectX 11)	√	√	
Panel	35.6-cm (14.0-in), high-definition (HD), light-emitting diode (LED), SVA BrightView (1366×768) display; typical brightness: 200 nits	√	√	√
	35.6-cm (14.0-in), high-definition (HD), light-emitting diode (LED), SVA Anti-glare (1366×768) display; typical brightness: 200 nits			√
	Supports LVDS	√	√	√
Memory	2 customer-accessible/upgradable memory module slots	√	√	
	1 customer-accessible/upgradable memory module slots			√
	Supports dual-channel memory	√	√	√
	Supports up to 8192 GB of system RAM	√	√	
	Supports up to 2048 GB of system RAM (2048×1)			√
	DDR3/1600-MHz/DDR3L-1600	√	√	

Category	Description	HP 245 (AMD)	HP 455 (AMD)	HP 455 (Elcot/ Kenya)
	DDR3/1333-MHz (DDR3/1600-MHz downgraded to DDR3/1333-MHz or DDR3/1333-MHz downgraded to 1066-MHz)	√		
	DDR3L-1600 MHz			√
	Supports the following configurations:	√	√	
	<ul style="list-style-type: none"> 8192-MB total system memory (4096×2; not supported on a 32-bit operating system) 6144-MB total system memory (4096×1 + 2048×1; not supported on a 32-bit operating system) 4096-MB total system memory (4096×1 or 2048×2; not supported with Windows 7 Starter 32 operating system) 2048-MB total system memory (2048×1) 			
Hard drives	Supports 6.35-cm (2.5-in) hard drives in 9.5-mm (.37-in) and 7.0-mm (.28-in) thicknesses	√	√	
	Supports 6.35-cm (2.5-in) hard drives in 7.0-mm (.28-in) thicknesses			√
	Customer-accessible	√	√	√
	Serial ATA	√	√	√
	Supports the following hard drives:	√		
	<ul style="list-style-type: none"> 750-GB, 5400-rpm, 9.5-mm (not supported with Windows 7 Starter OS) 640-GB, 5400-rpm, 9.5-mm (not supported with Windows 7 Starter OS) 500-GB, 5400-rpm, 9.5-mm or 7.0-mm 320-GB, 5400-rpm, 9.5-mm or 7.0-mm 			
	Supports the following hard drives:		√	
	<ul style="list-style-type: none"> 750-GB, 5400-rpm, 9.5-mm (not supported with Windows 7 Starter OS) 500-GB, 5400-rpm, 9.5-mm or 7.0-mm 320-GB, 5400-rpm, 9.5-mm or 7.0-mm 			
	Supports the following hard drives:			√
	<ul style="list-style-type: none"> 320-GB, 5400-rpm, 7.0-mm 250-GB, 5400-rpm, 7.0-mm 			
Optical drive	Fixed	√	√	

Category	Description	HP 245 (AMD)	HP 455 (AMD)	HP 455 (Elcot/ Kenya)
	Serial ATA	√	√	
	12.7-mm tray load	√	√	
	DVD±RW and CD-RW Super Multi Double-Layer Combo Drive	√	√	
	Supports Zero-Power optical drive	√	√	
	Supports weight saver	√		
	No optical drive			√
Audio/ video	Single digital microphone	√	√	
	HD audio	√		√
	Altec Lansing speakers	√	√	√
	SRS Premium sound		√	√
	Two speakers	√	√	√
	Supports Microsoft Premium requirements	√		
	HP TrueVision HD webcam (fixed, no tilt with activity LED, 1280×720 by 30 frames per second)	√	√	
	Fixed Integrated VGA webcam with single digital microphone; 640×480, F/2.8, up to 30 frames per second	√	√	√
	No webcam option			√
Ethernet	Integrated 10/100/1000 network interface card (NIC)	√	√	
	Integrated 10/100 network interface card (NIC)		√	√
Wireless	Integrated wireless local area network (WLAN) options by way of wireless module	√	√	√
	One or two WLAN antennas built into display assembly	√	√	√

Category	Description	HP 245 (AMD)	HP 455 (AMD)	HP 455 (Elcot/ Kenya)
	Support for the following WLAN formats:	√	√	
	<ul style="list-style-type: none"> Atheros AR9485 802.11b/g/n 1x1 WiFi Adapter Atheros 9485GN 802.11b/g/n 1x1 WiFi and 3012 Bluetooth 4.0 Combo Adapter Atheros AR9565 802.11bgn 1x1 WiFi + BT4.0 combo Adapter Broadcom 4313GN 802.11b/g/n 1x1 WiFi and 20702 Bluetooth 4.0 Combo Adapter Ralink WLAN Ralink Ripple3 RT5390F_802.11 b/g/n 1x1 PCIe HMC Ralink RT3290LE 802.11bgn 1x1 Wi-Fi and Bluetooth 4.0 Combo Adapter Ralink RT5390R 802.11bgn 1x1 Wi-Fi Adapter 			
	non Intel 1x1 802.11 b/g/n w/ *single antenna			√
External media card	HP Multi-Format Digital Media Reader supports the following digital card formats:		√	
	<ul style="list-style-type: none"> Secure Digital (SD) Memory Card Secure Digital Extended Capacity (SDxC) Memory Card Secure Digital High Capacity (SDHC) Memory Card Ultra High Speed MultiMediaCard (UHS/MMC) 			
	HP Multi-Format Digital Media Reader supports the following digital card formats:	√		√
	<ul style="list-style-type: none"> Secure Digital (SD) Memory Card Secure Digital Extended Capacity (SDxC) Memory Card Secure Digital High Capacity (SDHC) Memory Card 			
Ports	3-pin AC power	√	√	√
	Audio-in (microphone)	√	√	√
	Audio-out (headphone)	√	√	√
	HDMI version 1.4 supporting 1920 x1200 @ 60Hz	√	√	√
	RJ-45 (Ethernet, includes link and activity lights)	√	√	√
	USB 2.0 (3 ports)	√	√	√
	VGA (Dsub 15 pin) supporting 2048x1536 external resolution @ 60 Hz, hot plug and unplug and auto-detection for correct output to wide-aspect vs. standard aspect video	√		

Category	Description	HP 245 (AMD)	HP 455 (AMD)	HP 455 (Elcot/Kenya)
	VGA (Dsub 15 pin) supporting 2048×1536 external resolution @ 75 Hz, hot plug and unplug and auto-detection for correct output to wide-aspect vs. standard aspect video		✓	✓
Keyboard/ pointing devices	Full-size textured pocket keyboard (no numeric keypad)	✓	✓	✓
	Full-size textured spill-resistant pocket keyboard (no numeric keypad)			✓
	TouchPad with multi-touch gestures, 2-finger scrolling, and pinch-zoom enabled	✓	✓	✓
	Taps enabled by default	✓	✓	✓
Power requirements	65-W RC V HP Smart AC adapter with localized cable plug support (3-wire plug with ground pin, supports 3-pin DC connector; for use in all countries except China and India)	✓		
	65-W RC V EM HP Smart AC adapter with localized cable plug support (3-wire plug with ground pin, supports 3-pin DC connector; for use in China and India only)	✓	✓	✓
	Support for the following batteries:	✓	✓	✓
	<ul style="list-style-type: none"> 6-cell, 47-Whr, 2.20-Ah Li-ion battery 			
Security	Security cable slot	✓	✓	✓
	TPM (hardware support)			✓
Operating system	Preinstalled:			
	Windows 8 Professional (64-bit)	✓		
	Windows 8 Standard (64-bit)	✓		
	Windows 8 (6-bit) Chinese Simplified		✓	
	Windows 8 EM/SL (64-bit)		✓	
	Windows 8 (National Academic version) with Microsoft Office Pro 2013			✓
	Windows 8 EM/SL 64-bit with Microsoft Office Pro 2013 Academic			✓
	Windows 7 Professional (64-bit)	✓		
	Windows 7 Home Premium (64-bit)	✓		
	Windows 7 Starter (32-bit, not supported on computer models equipped with a 640-GB or 750-GB hard drive)	✓		
	Windows 7 (32-bit) Chinese Simplified		✓	
	SUSE Linux	✓		

Category	Description	HP 245 (AMD)	HP 455 (AMD)	HP 455 (Elcot/Kenya)
	FreeDOS 2.0		√	
	Web release:			
	Windows XP		√	
	Driver support:			
	Windows 7 (64-bit) drivers			√
	Windows 8 (64-bit) drivers		√	
	Windows 7 (32/64-bit) drivers		√	
	Windows XP 32-bit drivers		√	
Serviceability	End-user replaceable parts:	√	√	
	<ul style="list-style-type: none"> • AC adapter • Battery • Hard drive • Memory modules (2) • Optical drive • WLAN module 			
	End-user replaceable parts:			√
	<ul style="list-style-type: none"> • AC adapter • Battery • Hard drive • Memory module • WLAN module 			

HP 240, HP 450, and HP 246 models (Intel models)

Category	Description	HP 240 (UMA)	HP 240 (discrete)	HP 450 (UMA)	HP 450 (discrete)	HP 246 (UMA)	HP 246 (discrete)	HP 246 (Elcot/Kenya)
Product name	HP 240 Notebook PC	√	√					
	HP 450 Notebook PC			√	√			
	HP 246 Notebook PC					√	√	√
Processors	Intel Core i5-3230M 2.60-GHz (3.0-MB L3 cache, dual core, 35 W) NOTE: Not available with Windows 7 Starter 32.	√	√	√	√			
	Intel Core i5-3210M 2.50-GHz (3.0-MB L3 cache, dual core, 35 W) NOTE: Not available with Windows 7 Starter 32.	√	√	√	√	√	√	
	Intel Core i5-2450M 2.50-GHz (3.0-MB L3 cache, dual core, 35 W)	√	√	√	√	√	√	
	Intel Core i3-3130M 2.60-GHz (3.0-MB L3 cache, dual core, 35 W) NOTE: Not available with Windows 7 Starter 32.	√	√	√	√	√	√	
	Intel Core i3-3120M 2.50-GHz (3.0-MB L3 cache, dual core, 35 W) NOTE: Not available with Windows 7 Starter 32.	√	√	√	√	√	√	
	Intel Core i3-3110M 2.40-GHz (3.0-MB L3 cache, dual core, 35 W) NOTE: Not available with Windows 7 Starter 32.	√	√	√	√	√	√	
	Intel Core i3-2370M 2.40-GHz (3.0-MB L3 cache, dual core, 35 W) NOTE: Not available with Windows 7 Starter 32.	√	√	√	√	√	√	

Category	Description	HP 240 (UMA)	HP 240 (discrete)	HP 450 (UMA)	HP 450 (discrete)	HP 246 (UMA)	HP 246 (discrete)	HP 246 (Elcot/Kenya)
	Intel Core i3-2350M 2.30-GHz (3.0-MB L3 cache, dual core, 35 W) NOTE: Not available with Windows 7 Starter 32.	√	√	√	√	√	√	
	Intel Core i3-2348M 2.30-GHz (3.0-MB L3 cache, dual core, 35 W)	√	√	√	√	√	√	
	Intel Core i3-2328M 2.20-GHz (3.0-MB L3 cache, dual core, 35 W)	√	√	√	√	√	√	
	Intel Pentium 2030M 2.50-GHz (2.0-MB L3 cache, dual core, 35 W) NOTE: Not available with Windows 7 Starter 32, Windows 7 Professional, or Windows 8.	√	√	√	√	√	√	
	Intel Pentium 2020M 2.40-GHz (2.0-MB L3 cache, dual core, 35 W) NOTE: Not available with Windows 7 Starter 32, Windows 7 Professional, or Windows 8.	√	√	√	√	√	√	√
	Intel Pentium B980 2.40-GHz (2.0-MB L3 cache, dual core, 35 W) NOTE: Not available with Windows 7 Starter 32, Windows 7 Professional, or Windows 8.	√	√	√	√	√	√	
	Intel Pentium B970 2.30-GHz (2.0-MB L3 cache, dual core, 35 W) NOTE: Not available with Windows 7 Starter 32 or Windows 8.	√	√	√	√	√	√	
	Intel Pentium B960 2.20-GHz (2.0-MB L3 cache, dual core, 35 W) NOTE: Not available with Windows 7 Starter 32 or Windows 8.	√	√	√	√	√	√	

Category	Description	HP 240 (UMA)	HP 240 (discrete)	HP 450 (UMA)	HP 450 (discrete)	HP 246 (UMA)	HP 246 (discrete)	HP 246 (Elcot/Kenya)
	Intel Pentium A1018 2.10-GHz (2.0-MB L3 cache, dual core, 35 W)							√
	Intel Pentium 1000M 1.80-GHz (2.0-MB L3 cache, dual core, 35 W)	√	√	√	√	√	√	√
	Intel Celeron B830 1.8-GHz (2.0-MB L3 cache, dual core, 35 W)	√	√	√	√	√	√	
	Intel Celeron B820 1.7-GHz (2.0-MB L3 cache, dual core, 35 W)	√	√	√	√	√	√	
	NOTE: Not available with Windows 8.							
	Intel Celeron B815 1.6-GHz (2.0-MB L3 cache, dual core, 35 W)	√	√	√	√	√	√	
	NOTE: Not available with Windows 8.							
	Intel Celeron B730 1.8-GHz (1.5-MB L3 cache, 35 W)	√	√	√	√	√	√	
	NOTE: Not available with Windows 8.							
Chipset	Intel HM75 Express Chipset (Core i5/i3 processors only)	√	√	√	√	√	√	
	Intel HM70 Express Chipset	√	√	√	√	√	√	√
Graphics	Switchable discrete graphics:							
	AMD Radeon HD 7450M Graphics with 1024-MB of dedicated video memory (128Mx16 DDR3 900-MHz x 4 PCs; supports DirectX 11)		√		√		√	
	NOTE: Not available with Windows 7 Starter.							
	UMA graphics:							

Category	Description	HP 240 (UMA)	HP 240 (discrete)	HP 450 (UMA)	HP 450 (discrete)	HP 246 (UMA)	HP 246 (discrete)	HP 246 (Elcot/Kenya)
	Intel HD Graphics 4000 (on computer models equipped with an Intel Core i5-3210M or i3-3110M processor; supports DirectX 11)	√						
	Intel HD Graphics 3000 (on computer models equipped with an Intel Core i3-2370M, i3-2350M, or i3-2308M processor; supports DirectX 10)							
	Intel HD Graphics (on computer models equipped with a Intel Pentium B970 or B960 or Celeron B820, B815, or B730 processor; supports DirectX 10)							
	Intel HD Graphics (GT1)	√		√		√		√
Panel	35.6-cm (14.0-in), HD, LED, SVA BrightView (1366x768) display; 200 nits	√	√	√	√	√	√	√
	35.6-cm (14.0-in), HD, LED, SVA Anti-glare (1366x768) display; 200 nits	√	√	√	√	√	√	√
	Supports LVDS	√	√	√	√	√	√	√
Memory	2 customer-accessible/upgradable memory module slots	√	√	√	√	√	√	
	1 customer-accessible/upgradable memory module slot							√
	Supports dual-channel memory	√	√	√	√	√	√	√
	Supports up to 8192 GB of system RAM	√	√	√	√	√	√	
	Supports up to 2048 GB of system RAM (2048x1)							√
	DDR3/1600-MHz (DDR3L-1600 as alternative source)	√	√	√	√	√	√	

Category	Description	HP 240 (UMA)	HP 240 (discrete)	HP 450 (UMA)	HP 450 (discrete)	HP 246 (UMA)	HP 246 (discrete)	HP 246 (Elcot/Kenya)
	DDR3/1333-MHz (DDR3/1600-MHz downgraded to DDR3/1333-MHz)	√	√					
	DDR3L-1600 MHz							√
	Supports the following configurations:	√	√	√	√	√	√	
	8-GB total system memory (4 GB×2; not supported on 32-bit OS)							
	6-GB total system memory (4 GB×1 + 2 GB×1; not supported on 32-bit)							
	4-GB total system memory (4 GB×1 or 2 GB×2; not supported with Windows 7 Starter 32)							
	2-GB total system memory (2 GB×1)							
Hard drives	Supports 6.35-cm (2.5-in) hard drives in 9.5-mm (.37-in) and 7.0-mm (.28-in) thicknesses	√	√	√	√	√	√	
	Supports 6.35-cm (2.5-in) hard drives in 7.0-mm (.28-in) thicknesses							√
	Customer-accessible	√	√	√	√	√	√	√
	Serial ATA	√	√	√	√	√	√	√
	Supports the following hard drives:	√	√					
	1-TB, 5400-rpm, 9.5-mm (not for Windows 7 Starter)							
	750-GB, 5400-rpm, 9.5-mm (not for Windows 7 Starter)							
	640-GB, 5400-rpm, 9.5-mm (not for Windows 7 Starter)							
	500-GB, 7200- or 5400-rpm, 9.5-mm or 7.0-mm							
	320-GB, 5400-rpm, 9.5-mm or 7.0-mm							

Category	Description	HP 240 (UMA)	HP 240 (discrete)	HP 450 (UMA)	HP 450 (discrete)	HP 246 (UMA)	HP 246 (discrete)	HP 246 (Elcot/Kenya)
	Supports the following hard drives:			✓	✓	✓	✓	
	750-GB, 5400-rpm, 9.5-mm (not for Windows 7 Starter)							
	500-GB, 5400-rpm, 9.5-mm or 7.0-mm							
	320-GB, 5400-rpm, 9.5-mm or 7.0-mm							
	Supports the following hard drives:							✓
	320-GB, 5400-rpm, 7.0-mm							
	250-GB, 5400-rpm, 7.0-mm							
Optical drive	Fixed, SATA	✓	✓	✓	✓	✓	✓	
	Supports Zero-Power optical drive	✓	✓	✓	✓	✓	✓	
	Weight saver available	✓	✓					
	12.7-mm tray load	✓	✓	✓	✓	✓	✓	
	DVD+/-RW Double-Layer SuperMulti	✓	✓	✓	✓	✓	✓	
	No optical drive							✓
Audio/video	Single digital microphone	✓	✓	✓	✓	✓	✓	
	HD audio	✓	✓	✓	✓	✓	✓	✓
	Altec Lansing speakers	✓	✓	✓	✓	✓	✓	✓
	SRS Premium sound (not supported in Windows XP)			✓	✓	✓	✓	✓
	Two speakers	✓	✓	✓	✓	✓	✓	✓
	Supports Microsoft Premium requirements	✓	✓					
	HP TrueVision HD webcam (fixed, no tilt with activity LED, 1280×720 by 30 frames per second)	✓	✓	✓	✓	✓	✓	
	Fixed Integrated VGA webcam with single digital microphone; 640×480, F/2.8, up to 30 frames per second	✓	✓	✓	✓	✓	✓	✓

Category	Description	HP 240 (UMA)	HP 240 (discrete)	HP 450 (UMA)	HP 450 (discrete)	HP 246 (UMA)	HP 246 (discrete)	HP 246 (Elcot/ Kenya)
	No webcam option							√
Ethernet	Integrated 10/100/1000 network interface card (NIC)	√	√	√	√	√	√	
	Integrated 10/100 NIC	√		√	√	√	√	√
Wireless	Integrated wireless local area network (WLAN) options by way of wireless module	√	√	√	√	√	√	√
	One or two WLAN antennas built into display assembly	√	√	√	√	√	√	√
	Support for the following WLAN formats:	√	√	√	√	√	√	
	Atheros AR9485 802.11b/g/n 1x1 WiFi Adapter							
	Atheros 9485GN 802.11b/g/n 1x1 WiFi and 3012 Bluetooth 4.0 Combo Adapter							
	Atheros AR9565 802.11bgn 1x1 WiFi + BT4.0 combo Adapter							
	Broadcom 4313GN 802.11b/g/n 1x1 WiFi and 20702 Bluetooth 4.0 Combo Adapter							
	Ralink WLAN Ralink Ripple3 RT5390F_802.11 b/g/n 1x1 PCIe HMC							
	Ralink RT3290LE 802.11bgn 1x1 Wi-Fi and Bluetooth 4.0 Combo Adapter							
	Ralink RT5390R 802.11bgn 1x1 Wi-Fi Adapter							
	non Intel 1x1 802.11 b/g/n w/ *single antenna							√

Category	Description	HP 240 (UMA)	HP 240 (discrete)	HP 450 (UMA)	HP 450 (discrete)	HP 246 (UMA)	HP 246 (discrete)	HP 246 (Elcot/Kenya)
External media card	HP Multi-Format Digital Media Reader:	√	√	√	√	√	√	√
	Secure Digital (SD) Memory Card							
	Secure Digital Extended Capacity (SDxC) Memory Card							
	Secure Digital High Capacity (SDHC) Memory Card							
Ports	3-pin AC power	√	√	√	√	√	√	√
	Audio-in (microphone)	√	√	√	√	√	√	√
	Audio-out (headphone)	√	√	√	√	√	√	√
	HDMI version 1.4 supporting 1920 × 1200 @ 60Hz	√	√	√	√	√	√	√
	RJ-45 (Ethernet, includes link and activity lights)	√	√	√	√	√	√	√
	USB 2.0 (3 ports)	√	√	√	√	√	√	√
	VGA (Dsub 15 pin) supporting 2048×1536 external resolution @ 75 Hz, hot plug and unplug and auto-detection for correct output to wide-aspect vs. standard aspect video	√	√	√	√	√	√	√
Keyboard/pointing devices	Full-size textured pocket keyboard (no numeric keypad)	√	√	√	√	√	√	√
	Full-size textured spill-resistant pocket keyboard (no numeric keypad)							√
	TouchPad with multi-touch gestures, 2-finger scrolling, and pinch-zoom enabled	√	√	√	√	√	√	√
	Taps enabled by default	√	√	√	√	√	√	√

Category	Description	HP 240 (UMA)	HP 240 (discrete)	HP 450 (UMA)	HP 450 (discrete)	HP 246 (UMA)	HP 246 (discrete)	HP 246 (Elcot/Kenya)
Power requirements	90-W PFC RC V HP Smart AC adapter with localized cable plug support (3-wire plug with ground pin, supports 3-pin DC connector; for use in all countries except China and India)		√					
	90-W PFC RC V EM HP Smart AC adapter with localized cable plug support (3-wire plug with ground pin, supports 3-pin DC connector; for use in China and India only)	√	√	√	√	√	√	
	65-W RC V HP Smart AC adapter with localized cable plug support (3-wire plug with ground pin, supports 3-pin DC connector; for use in all countries except China and India)	√						√
	65-W RC V EM HP Smart AC adapter with localized cable plug support (3-wire plug with ground pin, supports 3-pin DC connector; for use in China and India only)	√		√		√		√
	Support for the following battery: 6-cell, 47-Whr, 2.20-Ah Li-ion battery	√	√	√	√	√	√	√
Security	Security cable slot	√	√	√	√	√	√	√
	TPM (hardware support)							√
Operating system	Preinstalled:							
	Windows 8 Professional (64-bit)	√	√					
	Windows 8 Standard (64-bit)	√	√					
	Windows 8 64-bit Chinese Simplified			√	√	√	√	

Category	Description	HP 240 (UMA)	HP 240 (discrete)	HP 450 (UMA)	HP 450 (discrete)	HP 246 (UMA)	HP 246 (discrete)	HP 246 (Elcot/Kenya)
	Windows 8 (National Academic version) with Microsoft Office Pro 2013							√
	Windows 8 EM/SL 64bit with Microsoft Office Pro 2013 Academic							√
	Windows 7 Professional (64-bit)	√	√					
	Windows 7 Home Premium (64-bit)	√	√					
	Windows 7 Home Basic (64-bit and 32-bit)	√	√					
	Windows 7 Starter (32-bit, not supported on computer models equipped with a 640-GB or 750-GB hard drive)	√	√					
	Windows 7 Home Basic (64-bit) Chinese Simplified					√	√	
	Windows 7 Professional (64-bit) Chinese Simplified					√	√	
	SUSE Linux	√	√	√	√	√	√	
	FreeDOS 1.0	√	√					
	FreeDOS 2.0			√	√	√	√	√
	Web release:							
	Windows XP	√	√					
	Driver support:							
	Windows 7 (64-bit) drivers							√
	Windows 7 (32/64-bit) drivers			√	√	√	√	
	Windows 8 (64-bit) drivers			√	√	√	√	
	Windows XP (32-bit) drivers			√	√	√	√	

Category	Description	HP 240 (UMA)	HP 240 (discrete)	HP 450 (UMA)	HP 450 (discrete)	HP 246 (UMA)	HP 246 (discrete)	HP 246 (Elcot/Kenya)
Serviceability	End-user replaceable parts:	√	√	√	√	√	√	
	<ul style="list-style-type: none"> • AC adapter • Battery • Hard drive • Memory modules (2) • Optical drive • WLAN module 							
	End-user replaceable parts:							√
	<ul style="list-style-type: none"> • AC adapter • Battery • Hard drive • Memory module • WLAN module 							

2 External component identification

Display

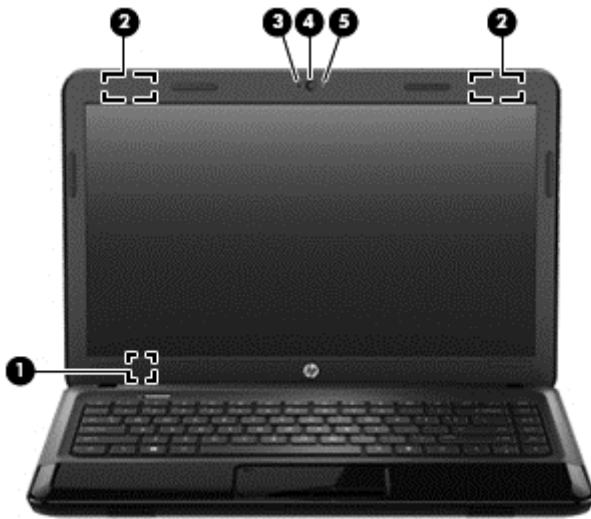

Component	Description
(1) Internal display switch	Turns off the display and initiates Sleep if the display is closed while the power is on. NOTE: The internal display switch is not visible from the outside of the computer.
(2) WLAN antenna*	Sends and receives wireless signals to communicate with wireless local area networks (WLANs).
(3) Internal microphone (select models only)	Records sound.
(4) Webcam (select models only)	Records video, captures still photographs, and allows video conferences and online chat by means of streaming video. To use the webcam, from the Start screen, type <code>cyberlink</code> , and then select CyberLink YouCam from the list of apps.
(5) Webcam light (select models only)	On: The webcam is in use.

*The antenna is not visible from the outside of the computer. For optimal transmission, keep the area immediately around the antenna free from obstructions. For wireless regulatory notices, see the section of the *Regulatory, Safety, and Environmental Notices* that applies to your country or region. These notices are located in Help and Support. To access Help and Support in Windows 8, from the Start screen, type `help`, and then select **Help and Support** from the list of apps.



Front



Component	Description
Speakers (2)	Produce sound.

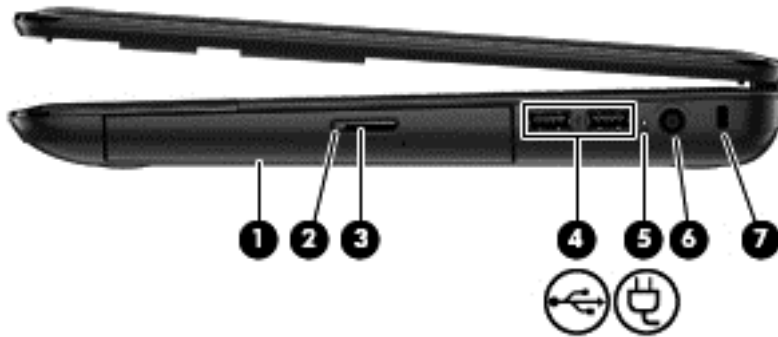





Right side

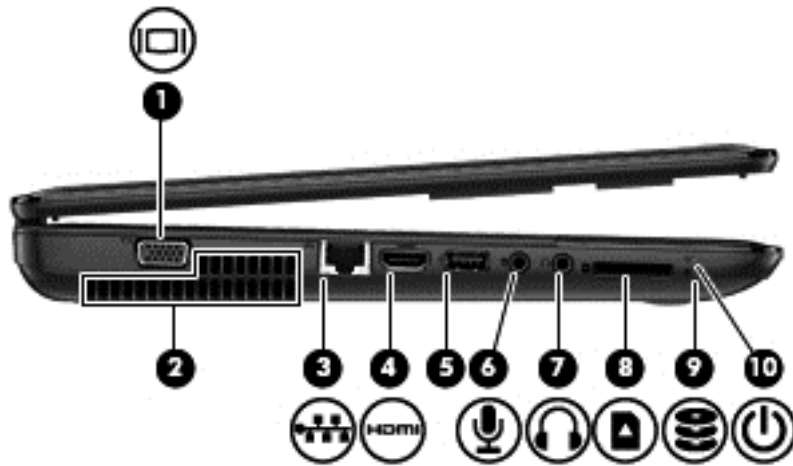



Component	Description
(1) Optical drive (select models only)	Reads an optical disc. NOTE: On select models, the optical drive also writes to an optical disc.
(2) Optical drive light (select models only)	<ul style="list-style-type: none"> Green: The optical drive is being accessed. Off: The optical drive is idle.
(3) Optical drive eject button (select models only)	Releases the disc tray.
(4)  USB 2.0 ports (2)	Connect optional USB devices.
(5)  AC adapter light	<ul style="list-style-type: none"> White: The AC adapter is connected and the battery is not charged. Amber: The AC adapter is connected and the battery is charging. Off: The computer is using DC power.
(6) Power connector	Connects an AC adapter.
(7) Security cable slot	Attaches an optional security cable to the computer. NOTE: The security cable is designed to act as a deterrent, but it may not prevent the computer from being mishandled or stolen.

Left side



Component	Description
(1) 	External monitor port Connects an external VGA monitor or projector.
(2)	Vents (2) NOTE: The computer fan starts up automatically to cool internal components and prevent overheating. It is normal for the internal fan to cycle on and off during routine operation.
(3) 	RJ-45 (network) jack Connects a network cable.
(4) 	HDMI port Connects an optional video or audio device, such as a high-definition television, or any compatible digital or audio device.
(5)	USB 2.0 port Connects an optional USB device.
(6) 	Audio-in (microphone) jack Connects an optional computer headset microphone, stereo array microphone, or monaural microphone.
(7) 	Audio-out (headphone) jack Connects optional powered stereo speakers, headphones, earbuds, a headset, or a television audio cable. WARNING! To reduce the risk of personal injury, adjust the volume before using headphones, earbuds, or a headset. For additional safety information, see the <i>Regulatory, Safety and Environmental Notices</i> . NOTE: When a device is connected to a headphone jack, the computer speakers are disabled.
(8) 	Media card reader Reads data from and writes data to memory cards such as SD.

Component	Description
(9)  Hard drive light	<ul style="list-style-type: none">• Blinking white: The hard drive is being accessed.
(10)  Power light	<ul style="list-style-type: none">• White: The computer is on.• Blinking white: The computer is in the Sleep state, which is an energy-saving mode. The computer shuts off power to the display and other unneeded components.• Off: The computer is off or in Hibernation. Hibernation is an energy-saving mode that uses the least amount of power.

Top



TouchPad

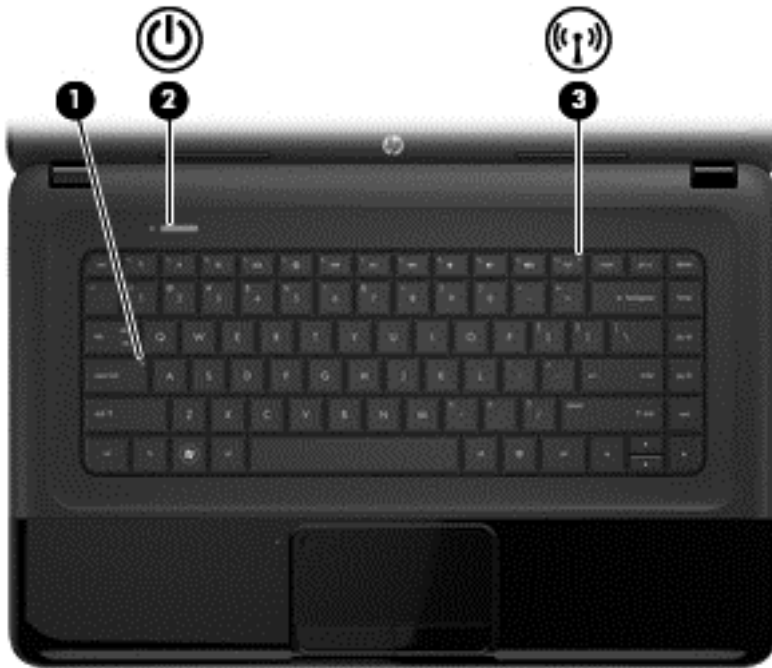

Component	Description
(1) TouchPad on/off button	Turns the TouchPad on or off.
(2) TouchPad light	<ul style="list-style-type: none">• On: The TouchPad is off.• Off: The TouchPad is on.
(3) TouchPad zone	Moves the on-screen pointer and selects or activates items on the screen.
(4) Left TouchPad button	Functions like the left button on an external mouse.
(5) Right TouchPad button	Functions like the right button on an external mouse.

Lights



Component	Description
(1) Caps lock light	On: Caps lock is on, which switches the keys to all capital letters.
(2)  Power light	<ul style="list-style-type: none">• White: The computer is on.• Blinking white: The computer is in the Sleep state, which is an energy-saving mode. The computer shuts off power to the display and other unneeded components.• Off: The computer is off or in Hibernation. Hibernation is an energy-saving mode that uses the least amount of power.
(3)  Wireless light	<ul style="list-style-type: none">• White: An integrated wireless device, such as a wireless local area network (WLAN) device and/or a Bluetooth® device, is on.• Amber: All wireless devices are off.





Buttons

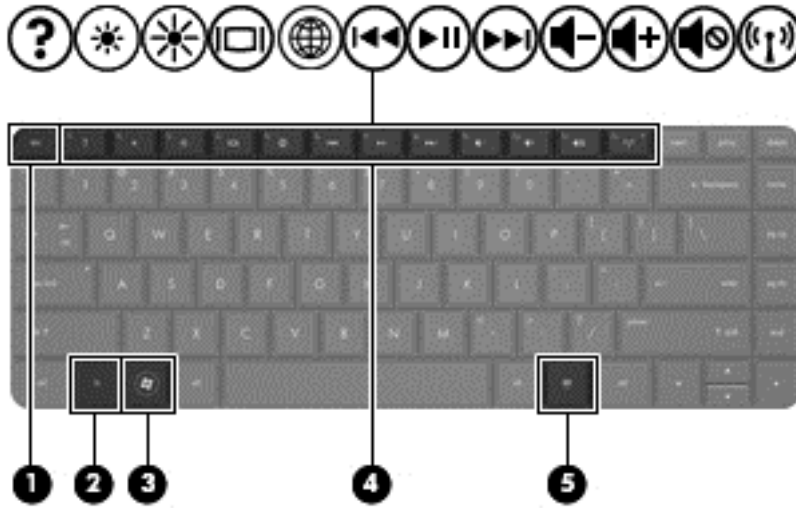

Component	Description
 Power button	<ul style="list-style-type: none">• When the computer is off, press the button to turn on the computer.• (Windows 7) When the computer is on, press the button briefly to initiate Sleep.• When the computer is in the Sleep state, press the button briefly to exit Sleep.• When the computer is in Hibernation, press the button down briefly to exit Hibernation. <p>CAUTION: Pressing and holding down the power button will result in the loss of unsaved information.</p> <p>If the computer has stopped responding and Microsoft® Windows shutdown procedures are ineffective, press and hold the power button down for at least 5 seconds to turn off the computer.</p> <p>To learn more about your power settings in Windows 8:</p> <ol style="list-style-type: none">1. From the Start screen, type <code>power options</code>.2. Click Settings, and then select Power Options from the options displayed. <p>To learn more about your power settings in Windows 7:</p> <p>To learn more about your power settings, select Start > Control Panel > System and Security > Power Options.</p>

Keys



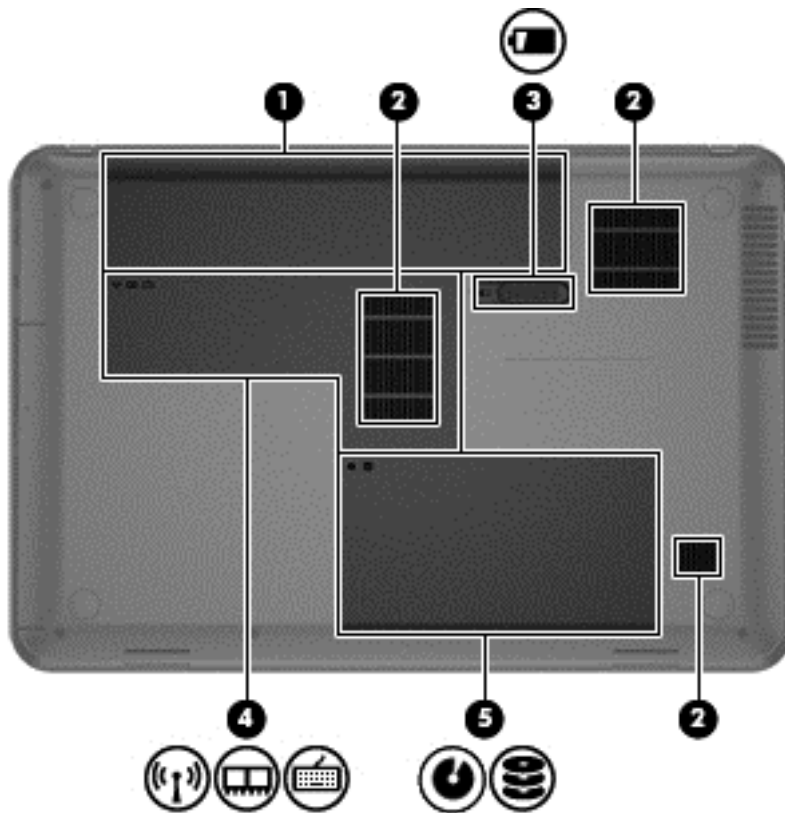

Component	Description
(1) esc key	Displays system information when pressed in combination with the fn key.
(2) fn key	Displays system information when pressed in combination with the esc key.
(3)  Windows 8 logo key  Windows 7 logo key	(Windows 8) Displays the Start screen. (Windows 7) Displays the Windows Start menu.
(4) Action keys	Execute frequently used system functions.
(5)  Windows 8 applications key  Windows 7 applications key	(Windows 8) Displays options for a selected object. (Windows 7) Displays a shortcut menu for items beneath the cursor.

Bottom

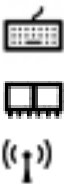

Component	Description	Description
(1)	Battery bay	Holds the battery.
(2)	Vents (3)	Enable airflow to cool internal components. NOTE: The computer fan starts up automatically to cool internal components and prevent overheating. It is normal for the internal fan to cycle on and off during routine operation.
(3)	 Battery release latch	Releases the battery from the battery bay.

Component	Description
<p>(4)</p>  <p>Wireless and memory module compartment</p>	<p>Contains the wireless and memory modules.</p> <p>CAUTION: To prevent an unresponsive system, replace the wireless module only with a wireless module authorized for use in the computer by the governmental agency that regulates wireless devices in your country or region. If you replace the module and then receive a warning message, remove the module to restore computer functionality, and then contact support through Help and Support. To access Help and Support, from the Start screen, type <code>help</code>, and then select Help and Support from the list of apps.</p>
<p>(5)</p>  <p>Hard drive bay</p>	<p>Contains the hard drive.</p>

Labels

The labels affixed to the computer provide information you may need when you troubleshoot system problems or travel internationally with the computer. The labels are in easily accessible locations.

- Service label—Provides important information, including the following:

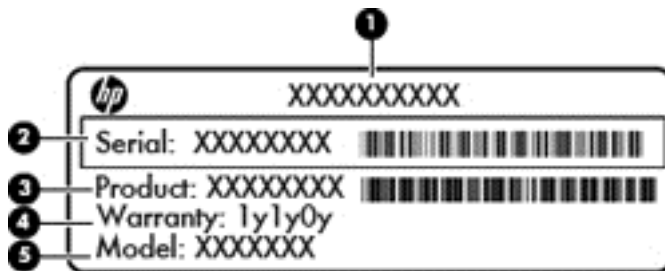

Component

- | | |
|-----|--|
| (1) | Product name |
| (2) | Serial number |
| (3) | Product part number |
| (4) | Warranty period |
| (5) | Model description (select models only) |
-

Have this information available when you contact support. The service label is affixed to the bottom of the computer.

- Regulatory label—Provides regulatory information about the computer. The regulatory label is affixed inside the battery bay.
- Wireless certification label or labels—Provide information about optional wireless devices and the approval markings of some of the countries or regions in which the devices have been approved for use. If your computer model includes one or more wireless devices, one or more certification labels are included with your computer. You may need this information when traveling internationally. Wireless certification labels are affixed inside the battery bay.

3 Illustrated parts catalog

Computer major components

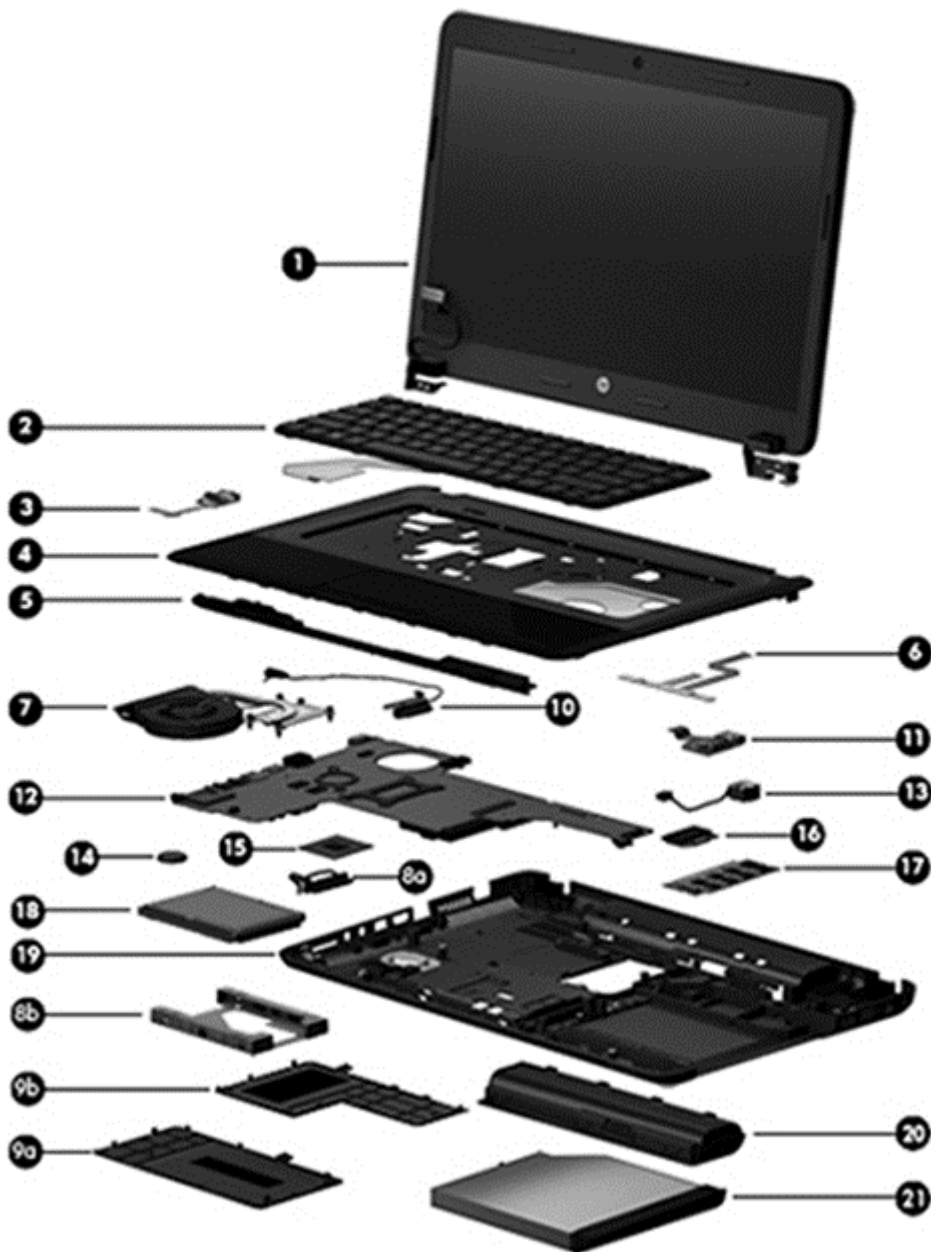

Item	Component	Spare part number
(1)	Display assembly (not spared)	
	NOTE: For more display assembly spare part information, see Display assembly subcomponents on page 36 .	
(2)	Keyboard (includes keyboard cable):	
	For use in Brazil	698694-201
	For use in India	698694-D61
	For use in Latin America	698694-161
	For use in South Korea	698694-AD1
	For use in Taiwan	698694-AB1
	For use in Thailand	698694-281
	For use in the United States	698694-001
(3)	Power button board (includes cable)	685098-001
(4)	Top cover (includes TouchPad)	
	For use in charcoal models	685762-001
	For use in black models	713530-001
(5)	Speakers (includes left and right speakers and cable)	685106-001
(6)	TouchPad button board (includes bracket and cables)	685099-001
(7)	Fan/heat sink assembly (includes replacement thermal materials):	
	For use only with computer models equipped with an AMD processor	688281-001
	For use only with computer models equipped with an Intel processor and a graphics subsystem with discrete video memory	685087-001
	For use only with computer models equipped with an Intel processor and a graphics subsystem with UMA video memory	685086-001
	Hard Drive Hardware Kit , includes:	685089-001
(8a)	Hard drive cable	
(8b)	Hard drive bracket	
	Plastics Kit , includes:	685100-001
(9a)	Hard drive compartment cover (includes one captive screw, secured by a C-clip)	
(9b)	Memory module/wireless module compartment cover (includes one captive screw, secured by a C-clip)	
	NOTE: See Plastics Kit on page 39 for more Plastics Kit spare part information.	
(10)	Optical drive cable (includes cable bracket)	685084-001
(11)	USB board (includes cable)	685097-001
(12)	System board (includes replacement thermal materials):	
	For use only with computer models equipped with an AMD E2-2000 processor	

Item	Component	Spare part number
	<ul style="list-style-type: none"> Models without Windows 8 	720634-001
	<ul style="list-style-type: none"> Models with Windows 8 Standard 	720634-501
	<ul style="list-style-type: none"> Models with Windows 8 Professional 	720634-601
	For use only with computer models equipped with an AMD E2-1800 processor	
	<ul style="list-style-type: none"> Models without Windows 8 	688853-001
	<ul style="list-style-type: none"> Models with Windows 8 Standard 	688853-501
	<ul style="list-style-type: none"> Models with Windows 8 Professional 	688853-601
	For use only with computer models equipped with an AMD E1-1500 processor	
	<ul style="list-style-type: none"> Models without Windows 8 	720635-001
	<ul style="list-style-type: none"> Models with Windows 8 Standard 	720635-501
	<ul style="list-style-type: none"> Models with Windows 8 Professional 	720635-601
	For use only with computer models equipped with an AMD E1-1200 processor	
	<ul style="list-style-type: none"> Models without Windows 8 	688852-001
	<ul style="list-style-type: none"> Models with Windows 8 Standard 	688852-501
	<ul style="list-style-type: none"> Models with Windows 8 Professional 	688852-601
	For use only with computer models equipped with an AMD E300 processor	
	<ul style="list-style-type: none"> Models without Windows 8 	688851-001
	<ul style="list-style-type: none"> Models with Windows 8 Standard 	688851-501
	<ul style="list-style-type: none"> Models with Windows 8 Professional 	688851-601
	For use only with computer models equipped with an AMD A6-5200 processor	
	<ul style="list-style-type: none"> Models without Windows 8 	730670-001
	<ul style="list-style-type: none"> Models with Windows 8 Standard 	730670-501
	<ul style="list-style-type: none"> Models with Windows 8 Professional 	730670-601
	For use only with computer models equipped with an AMD A4-5000 processor	
	<ul style="list-style-type: none"> Models without Windows 8 	730671-001
	<ul style="list-style-type: none"> Models with Windows 8 Standard 	730671-501
	<ul style="list-style-type: none"> Models with Windows 8 Professional 	730671-601
	For use only with computer models equipped with an AMD A60M processor	
	<ul style="list-style-type: none"> Models without Windows 8 	747492-001
	<ul style="list-style-type: none"> Models with Windows 8 Standard 	747492-501
	<ul style="list-style-type: none"> Models with Windows 8 Professional 	747492-601
	For use only with computer models equipped with an Intel Core i5 or i3 processor and a graphics subsystem with discrete video memory	

Item	Component	Spare part number
	<ul style="list-style-type: none"> Models without Windows 8 	694693-001
	<ul style="list-style-type: none"> Models with Windows 8 Standard 	694693-501
	<ul style="list-style-type: none"> Models with Windows 8 Professional 	694693-601
	For use only with computer models equipped with an Intel Pentium or Celeron processor and a graphics subsystem with discrete video memory	
	<ul style="list-style-type: none"> Models without Windows 8 	694694-001
	<ul style="list-style-type: none"> Models with Windows 8 Standard 	694694-501
	<ul style="list-style-type: none"> Models with Windows 8 Professional 	694694-601
	For use only with computer models equipped with an Intel Core i5 or i3 processor and a graphics subsystem with UMA video memory	
	<ul style="list-style-type: none"> Models without Windows 8 	685761-001
	<ul style="list-style-type: none"> Models with Windows 8 Standard 	685761-501
	<ul style="list-style-type: none"> Models with Windows 8 Professional 	685761-601
	For use only with computer models equipped with an Intel Core i5 or i3 processor and a graphics subsystem with UMA video memory (RCTO system board for use in Brazil and India only)	
	<ul style="list-style-type: none"> Models without Windows 8 	685107-001
	<ul style="list-style-type: none"> Models with Windows 8 Standard 	685107-501
	<ul style="list-style-type: none"> Models with Windows 8 Professional 	685107-601
	For use only with computer models equipped with an Intel Pentium or Celeron processor and a graphics subsystem with UMA video memory	
	<ul style="list-style-type: none"> Models without Windows 8 	685768-001
	<ul style="list-style-type: none"> Models with Windows 8 Standard 	685768-501
	<ul style="list-style-type: none"> Models with Windows 8 Professional 	685768-601
	For use only with computer models equipped with an Intel Pentium or Celeron processor and a graphics subsystem with UMA video memory (RCTO system board for use in Brazil and India only)	
	<ul style="list-style-type: none"> Models without Windows 8 	685783-001
	<ul style="list-style-type: none"> Models with Windows 8 Standard 	685783-501
	<ul style="list-style-type: none"> Models with Windows 8 Professional 	685783-601
	For use only with HP 246 models for Elcot and Kenya:	
	<ul style="list-style-type: none"> Models without Windows 8 	747746-001
	<ul style="list-style-type: none"> Models with Windows 8 Standard 	747746-501
	<ul style="list-style-type: none"> Models with Windows 8 Professional 	747746-601
(13)	Power connector cable	685085-001

Item	Component	Spare part number
(14)	RTC battery	449137-001
(15)	Processor (includes replacement thermal materials):	
	Intel Core i5 processors (3.0-MB L3 cache, dual core, 35 W):	
	• 3230M 2.60-GHz processor	711903-001
	• 3210M 2.50-GHz processor	680645-001
	• 2450M 2.50-GHz processor	676359-001
	Intel Core i3 processors (3.0-MB L3 cache, dual core, 35 W):	
	• 3130M 2.60-GHz processor	713163-001
	• 3120M 2.50-GHz processor	700627-001
	• 3110M 2.40-GHz processor	682417-001
	• 2370M 2.40-GHz processor	677152-001
	• 2350M 2.30-GHz processor	653340-001
	• 2348M 2.30-GHz processor	713165-001
	• 2328M 2.20-GHz processor	693542-001
	Intel Pentium processors (2.0-MB L3 cache, dual core, 35 W):	
	• 2030M 2.50-GHz processor	713164-001
	• 2020M 2.40-GHz processor	700628-001
	• B980 2.40-GHz processor	692428-001
	• B970 2.30-GHz processor	676785-001
	• B960 2.20-GHz processor	664662-001
	• B950 2.10-GHz processor	653338-001
	Intel Celeron processors (2.0-MB L3 cache, dual core, 35 W):	
	• 1000M 1.8-GHz processor	713162-001
	• B830 1.8-GHz processor	699547-001
	• B820 1.7-GHz processor	690537-001
	• B815 1.6-GHz processor	677153-001
	• B730 1.8-GHz processor	690536-001
(16)	WLAN module:	
	Atheros AR9485 802.11b/g/n 1x1 WiFi Adapter	675794-001
	Atheros 9485GN 802.11b/g/n 1x1 WiFi and 3012 Bluetooth 4.0 Combo Adapter	655795-001
	Broadcom 4313GN 802.11b/g/n 1x1 WiFi and 20702 Bluetooth 4.0 Combo Adapter	657325-001
	Ralink WLAN Ralink Ripple3 RT5390F_802.11 b/g/n 1x1 PCIe HMC	670691-001

Item	Component	Spare part number
	Atheros AR9565 802.11bgn 1x1 WiFi + BT4.0 combo Adapter	690019-001
	Ralink RT3290LE 802.11bgn 1x1 Wi-Fi and Bluetooth 4.0 Combo Adapter	690020-001
	Ralink RT5390R 802.11bgn 1x1 Wi-Fi Adapter	691415-001
	Atheros AR9485 802.11b/g/n WiFi Adapter for use in Brazil	712639-201
	Atheros HB125 802.11 b/g/n 1x1 Wi-Fi + Bluetooth 4.0 Combo Adapter	699834-201
	Realtek RTL8188EE 802.11bgn Wi-Fi Adapter	709848-001
	Qualcomm QCA9565 802.11bgn 1x1 Wi-Fi + BT4.0 Combo Adapter	733476-001
(17)	Memory module (PC3, 12800, 1600-MHz):	
	4 GB	641369-001
	2 GB	652972-001
(18)	Hard drive (6.35-cm (2.5-in), SATA; does not include hard drive cable or bracket):	
	NOTE: The hard drive cable and bracket are included in the Hard Drive Hardware Kit, spare part number 685089-001.	
	1-TB, 5400-rpm, 2.5-in	676521-001
	750-GB, 5400-rpm, 2.5-in	634250-001
	640-GB, 5400-rpm, 2.5-in (HP 240/HP 245 only)	669300-001
	500-GB, 7200-rpm, 2.5-in	634925-001
	500-GB, 5400-rpm, 2.5-in	669299-001
	320-GB, 5400-rpm, 2.5-in	622643-001
(19)	Base enclosure	704201-001
(20)	Battery:	
	6-cell, 55-Whr, 2.55-Ah Li-ion battery	593554-001
	6-cell, 47-Whr, 2.20-Ah Li-ion battery	593553-001
(21)	Optical drive (DVD±RW and CD-RW Super Multi Double-Layer Combo Drive; includes rear optical drive bracket but does not include optical drive cable or cable bracket)	685096-001
	NOTE: The optical drive cable and cable bracket are included in the optical drive cable kit, spare part number 685084-001.	

Display assembly subcomponents

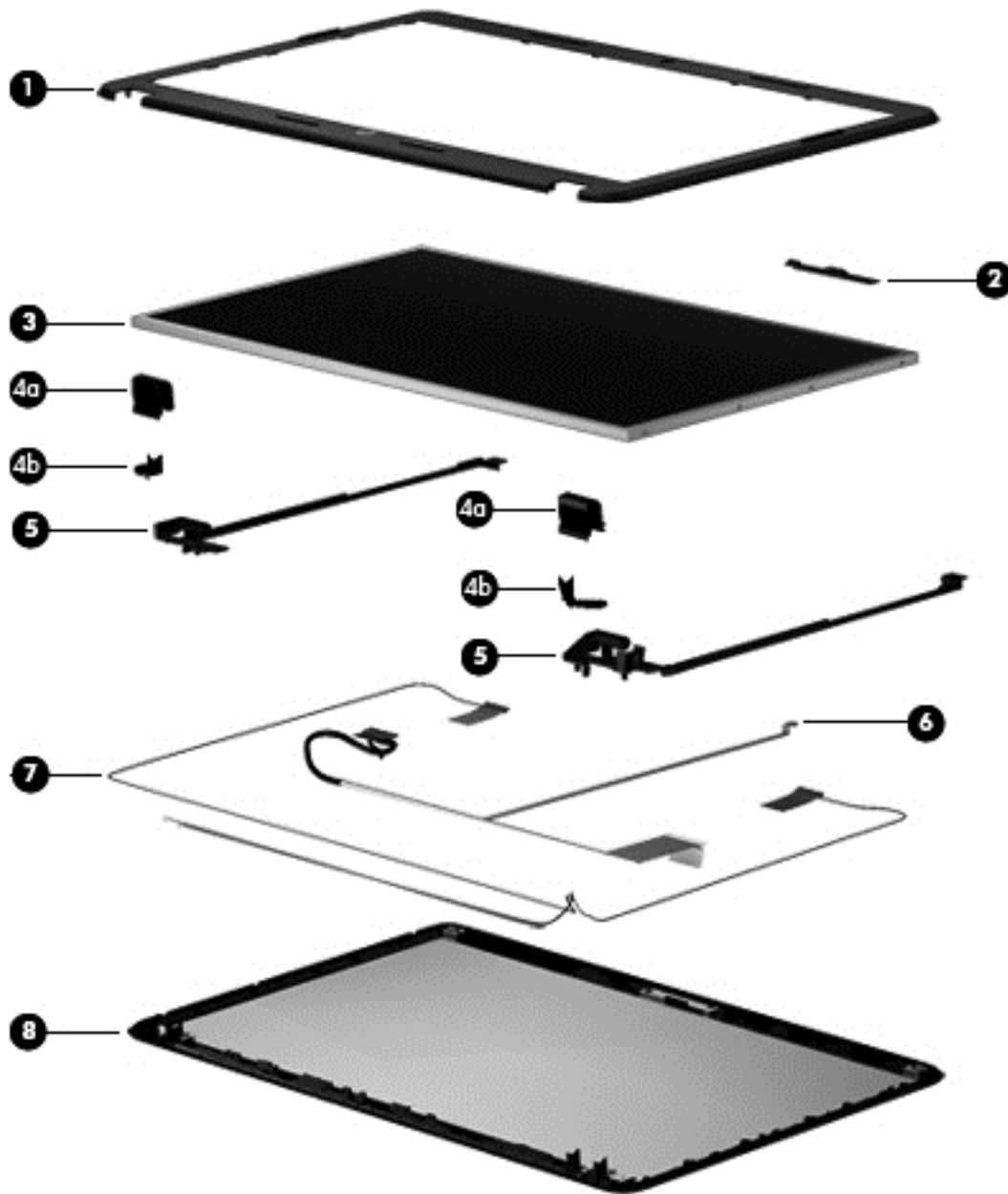

Item	Component	Spare part number
(1)	Display bezel (includes Mylar screw covers)	
	For use in HP 240 and HP 455 models with a webcam	685081-001
	For use with HP 246 and HP 455 models without a webcam	748031-001
(2)	Webcam/microphone module:	
	HP TrueVision HD webcam/microphone module	694747-001
	HP VGA webcam/microphone module	685112-001

Item	Component	Spare part number
(3)	Display panel:	
	35.6-cm (14.0-in), HD, LED, BrightView display panel	685101-001
	35.6-cm (14.0-in), HD, LED, Anti-glare display panel	694746-001
	Hinge covers (includes Mylar screw covers):	685088-001
(4a)	Top hinge covers	
(4b)	Side hinge covers	
(5)	Hinges (includes Mylar screw covers)	685090-001
(6)	Display cable (includes display panel cable and webcam/microphone cable; also includes Mylar screw covers)	
	For use in HP 240 and HP 455 models with a webcam	685083-001
	For use in HP 246 and HP 455 models without a webcam	748030-001
(7)	Antennas (includes wireless antenna cables and transceivers; also includes Mylar screw covers)	685076-001
	NOTE: Models may have either one or two antennas installed.	
(8)	Display enclosure (includes Mylar screw covers)	
	For use in charcoal models	685756-001
	For use in black models	713529-001
	Rubber display bumpers (not illustrated)	685102-001

Mass storage devices

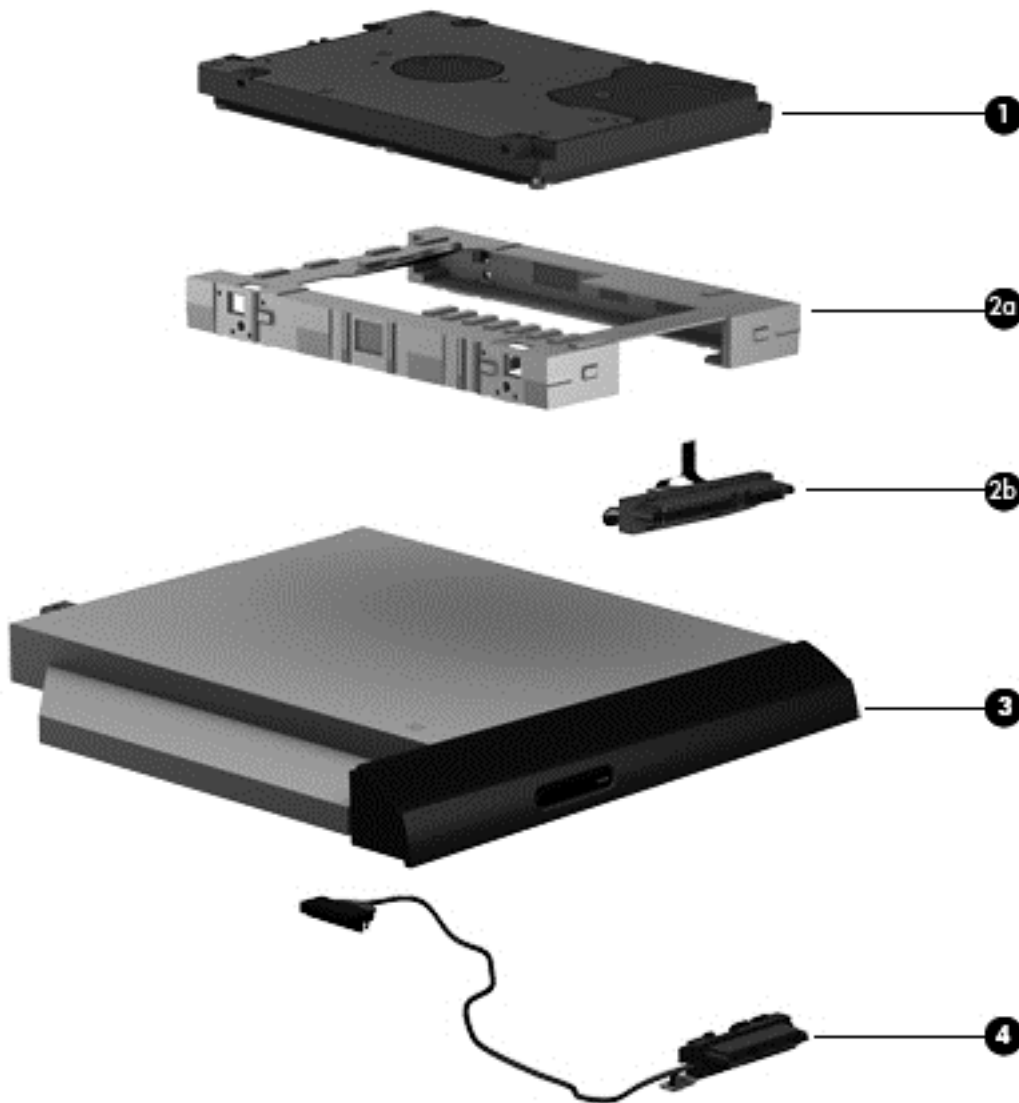

Item	Component	Spare part number
(1)	Hard drive (6.35-cm (2.5-in), SATA; does not include hard drive cable or bracket): NOTE: The hard drive cable and bracket are included in the Hard Drive Hardware Kit, spare part number 685089-001.	
	1-TB, 5400-rpm, 2.5-in	676521-001
	750-GB, 5400-rpm, 2.5-in	634250-001
	640-GB, 5400-rpm, 2.5-in (HP 240/HP 245 only)	669300-001
	500-GB, 7200-rpm, 2.5-in	634925-001
	500-GB, 5400-rpm, 2.5-in	669299-001

Item	Component	Spare part number
	320-GB, 5400-rpm, 2.5-in	622643-001
	Hard Drive Hardware Kit , includes:	685089-001
(2a)	Hard drive bracket	
(2b)	Hard drive cable	
(3)	Optical drive (DVD±RW and CD-RW Super Multi Double-Layer Combo Drive; includes rear optical drive bracket but does not include optical drive cable or cable bracket) NOTE: The optical drive cable and cable bracket are included in the optical drive cable kit, spare part number 685084-001.	685096-001
(4)	Optical drive cable (includes cable bracket)	685084-001

Plastics Kit



Item	Component	Spare part number
	Plastics Kit , includes:	685100-001
(1)	Hard drive compartment cover (includes one captive screw, secured by a C-clip)	
(2)	Memory module/wireless module compartment cover (includes one captive screw, secured by a C-clip)	

Miscellaneous parts

Component	Spare part number
HP Smart AC adapter:	
For use with computer models equipped with discrete graphics:	
90-W PFC RC V HP Smart AC adapter (for use in all countries except China and India)	693712-001
90-W PFC RC V EM HP Smart AC adapter (for use in China and India only)	693713-001
For use with computer models equipped with UMA graphics:	
65-W RC V HP Smart AC adapter (for use in all countries except China and India)	693711-001
65-W RC V EM HP Smart AC adapter (for use in China and India only)	693710-001
Power cord (3-pin, black, 1.83-m):	
For use in Argentina	490371-D01
For use in Brazil	490371-202
For use in India	490371-D61
For use in North America	490371-001
For use in the People's Republic of China	490371-AA1
For use in South Korea	490371-AD1
For use in Taiwan	490371-AB1
For use in Thailand	490371-201
For use in the United Kingdom and Singapore	490371-031
Rubber computer feet	685103-001
Screw Kit	685105-001
Thermal pad (for use with all models)	651046-001
Nylon case	612757-001
Top load case	679921-001

Sequential part number listing

CSR flag designations:

A = Mandatory

B = Optional

C = Service technician recommended

N = Non-user replaceable

Spare part number	CSR flag	Description
449137-001	A	RTC battery
490371-001	A	Power cord for use in North America (3-pin, black, 1.83-m)
490371-031	A	Power cord for use in the United Kingdom and Singapore (3-pin, black, 1.83-m)
490371-201	A	Power cord for use in Thailand (3-pin, black, 1.83-m)
490371-202	A	Power cord for use in Brazil (3-pin, black, 1.83-m)
490371-AA1	A	Power cord for use in the People's Republic of China (3-pin, black, 1.83-m)
490371-AB1	A	Power cord for use in Taiwan (3-pin, black, 1.83-m)
490371-AD1	A	Power cord for use in South Korea (3-pin, black, 1.83-m)
490371-D01	A	Power cord for use in Argentina (3-pin, black, 1.83-m)
490371-D61	A	Power cord for use in India (3-pin, black, 1.83-m)
593553-001	A	6-cell, 47-Whr, 2.20-Ah Li-ion battery
593554-001	A	6-cell, 55-Whr, 2.55-Ah Li-ion battery
612757-001	A	Nylon case
622643-001	A	320-GB, 5400-rpm, 2.5-in SATA hard drive (does not include hard drive cable or bracket)
634250-001	A	750-GB, 5400-rpm, 2.5-in SATA hard drive (does not include hard drive cable or bracket)
634925-001	A	500-GB, 7200-rpm, 2.5-in SATA hard drive (does not include hard drive cable or bracket)
641369-001	A	4-GB memory module (PC3, 12800, 1600-MHz)
651046-001	N	Thermal pad (for use with all models)
652972-001	A	2-GB memory module (PC3, 12800, 1600-MHz)
653338-001	N	Intel Pentium B950 2.10-GHz processor (2.0-MB L3 cache, dual core, 35 W)
653340-001	N	Intel Core i3-2350M 2.30-GHz processor (3.0-MB L3 cache, dual core, 35 W; includes replacement thermal materials)
655795-001	A	Atheros 9485GN 802.11b/g/n 1x1 WiFi and 3012 Bluetooth 4.0 Combo Adapter
657325-001	A	Broadcom 4313GN 802.11b/g/n 1x1 WiFi and 20702 Bluetooth 4.0 Combo Adapter

Spare part number	CSR flag	Description
664662-001	N	Intel Pentium B960, 2.20-GHz processor (2.0-MB L3 cache, dual core, 35 W; includes replacement thermal materials)
669299-001	A	500-GB, 5400-rpm, 2.5-in SATA hard drive (does not include hard drive cable or bracket)
669300-001	A	640-GB, 5400-rpm, 2.5-in SATA hard drive (does not include hard drive cable or bracket) (HP 240/HP 245 only)
670691-001	A	Ralink WLAN Ralink Ripple3 RT5390F_802.11 b/g/n 1x1 PCIe HMC
675794-001	A	Atheros AR9485 802.11b/g/n 1x1 WiFi Adapter
676521-001	A	1-TB, 5400-rpm, 2.5-in SATA hard drive (does not include hard drive cable or bracket)
676359-001	N	Intel Core i5 2450, 2.50-GHz processor (3.0-MB L3 cache, dual core, 35 W)
676785-001	N	Intel Pentium B970, 2.30-GHz processor (2.0-MB L3 cache, dual core, 35 W; includes replacement thermal materials)
677152-001	N	Intel Core i3-2370M, 2.40-GHz processor (3.0-MB L3 cache, dual core, 35 W; includes replacement thermal materials)
677153-001	N	Intel Celeron B815, 1.6-GHz processor (2.0-MB L3 cache, dual core, 35 W; includes replacement thermal materials)
679921-001	A	Top load case
680645-001	N	Intel Core i5 3210, 2.50-GHz processor (3.0-MB L3 cache, dual core, 35 W)
682417-001	N	Intel Core i3-3110M, 2.40-GHz processor (3.0-MB L3 cache, dual core, 35 W; includes replacement thermal materials)
685076-001	N	Antennas (includes wireless antenna cables and transceivers; also includes Mylar screw covers)
685081-001	N	Display bezel for use in HP 240 and HP 455 models with a webcam (includes Mylar screw covers)
685083-001	N	Display cable for use in HP 240 and HP 455 models with a webcam (includes display panel cable and webcam/microphone cable; also includes Mylar screw covers)
685084-001	N	Optical drive cable (includes cable bracket)
685085-001	N	Power connector cable
685086-001	N	Fan/heat sink assembly for use only with computer models equipped with an Intel processor and a graphics subsystem with UMA video memory (includes replacement thermal materials)
685087-001	N	Fan/heat sink assembly for use only with computer models equipped with an Intel processor and a graphics subsystem with discrete video memory (includes replacement thermal materials)
685088-001	N	Hinge covers (includes Mylar screw covers)
685089-001	N	Hard Drive Hardware Kit (includes hard drive cable and bracket)
685090-001	N	Hinges (includes Mylar screw covers)
685096-001	A	Optical drive (DVD±RW and CD-RW Super Multi Double-Layer Combo Drive; includes rear optical drive bracket but does not include optical drive cable or cable bracket)
685097-001	N	USB board (includes cable)
685098-001	N	Power button board (includes cable)

Spare part number	CSR flag	Description
685099-001	N	TouchPad button board (includes bracket and cables)
685100-001	N	Plastics Kit (includes hard drive compartment cover, memory module/wireless module compartment cover, and captive screws secured by C-clips)
685101-001	N	35.6-cm (14.0-in), HD, LED, BrightView display panel
685102-001	N	Rubber display bumpers
685103-001	N	Rubber computer feet
685105-001	N	Screw Kit
685106-001	N	Speakers (includes left and right speakers and cable)
685107-001	N	System board for use only with computer models without Windows 8 and equipped with an Intel Core i5 or i3 processor and a graphics subsystem with UMA video memory (RCTO system board for use in Brazil and India only; includes replacement thermal materials)
685107-501	N	System board for use only with computer models with Windows 8 Standard and equipped with an Intel Core i5 or i3 processor and a graphics subsystem with UMA video memory (RCTO system board for use in Brazil and India only; includes replacement thermal materials)
685107-601	N	System board for use only with computer models with Windows 8 Professional and equipped with an Intel Core i5 or i3 processor and a graphics subsystem with UMA video memory (RCTO system board for use in Brazil and India only; includes replacement thermal materials)
685112-001	N	HP VGA webcam/microphone module
685756-001	N	Display enclosure (includes Mylar screw covers)
685761-001	N	System board for use only with computer models without Windows 8 and equipped with an Intel Core i5 or i3 processor and a graphics subsystem with UMA video memory (includes replacement thermal materials)
685761-501	N	System board for use only with computer models with Windows 8 Standard and equipped with an Intel Core i5 or i3 processor and a graphics subsystem with UMA video memory (includes replacement thermal materials)
685761-601	N	System board for use only with computer models with Windows 8 Professional and equipped with an Intel Core i5 or i3 processor and a graphics subsystem with UMA video memory (includes replacement thermal materials)
685762-001	N	Top cover for use in charcoal models (includes TouchPad)
685768-001	N	System board for use only with computer models without Window 8 and equipped with an Intel Pentium or Celeron processor and a graphics subsystem with UMA video memory (includes replacement thermal materials)
685768-501	N	System board for use only with computer models with Window 8 Standard and equipped with an Intel Pentium or Celeron processor and a graphics subsystem with UMA video memory (includes replacement thermal materials)
685768-601	N	System board for use only with computer models with Window 8 Professional and equipped with an Intel Pentium or Celeron processor and a graphics subsystem with UMA video memory (includes replacement thermal materials)
685783-001	N	System board for use only with computer models without Windows 8 and equipped with an Intel Pentium or Celeron processor and a graphics subsystem with UMA video memory (RCTO system board for use in Brazil and India only; includes replacement thermal materials)

Spare part number	CSR flag	Description
685783-501	N	System board for use only with computer models with Windows 8 Standard and equipped with an Intel Pentium or Celeron processor and a graphics subsystem with UMA video memory (RCTO system board for use in Brazil and India only; includes replacement thermal materials)
685783-601	N	System board for use only with computer models with Windows 8 Professional and equipped with an Intel Pentium or Celeron processor and a graphics subsystem with UMA video memory (RCTO system board for use in Brazil and India only; includes replacement thermal materials)
688281-001	N	Fan/heat sink assembly for use only with computer models equipped with an AMD processor (includes replacement thermal materials)
688851-001	N	System board for use only with computer models without Windows 8 and equipped with an AMD E300 processor (includes replacement thermal materials)
688851-501	N	System board for use only with computer models with Windows 8 Standard and equipped with an AMD E300 processor (includes replacement thermal materials)
688851-601	N	System board for use only with computer models with Windows 8 Professional and equipped with an AMD E300 processor (includes replacement thermal materials)
688852-001	N	System board for use only with computer models without Windows 8 and equipped with an AMD E1-1200 processor (includes replacement thermal materials)
688852-501	N	System board for use only with computer models with Windows 8 Standard and equipped with an AMD E1-1200 processor (includes replacement thermal materials)
688852-601	N	System board for use only with computer models with Windows 8 Professional and equipped with an AMD E1-1200 processor (includes replacement thermal materials)
688853-001	N	System board for use only with computer models without Windows 8 and equipped with an AMD E2-1800 processor (includes replacement thermal materials)
688853-501	N	System board for use only with computer models with Windows 8 Standard and equipped with an AMD E2-1800 processor (includes replacement thermal materials)
688853-601	N	System board for use only with computer models with Windows 8 Professional and equipped with an AMD E2-1800 processor (includes replacement thermal materials)
690019-001	A	Atheros AR9565 802.11bgn 1x1 WiFi + BT4.0 combo Adapter
690020-001	A	Ralink RT3290LE 802.11bgn 1x1 Wi-Fi and Bluetooth 4.0 Combo Adapter
690536-001	N	Intel Celeron B730, 1.8-GHz processor (1.5-MB L3 cache, 35 W; includes replacement thermal materials)
690537-001	N	Intel Celeron B820, 1.7-GHz processor (2.0-MB L3 cache, dual core, 35 W; includes replacement thermal materials)
691415-001	A	Ralink RT5390R 802.11bgn 1x1 Wi-Fi Adapter
692428-001	N	Intel Pentium B980, 2.40-GHz processor (2.0-MB L3 cache, dual core, 35 W)
693542-001	N	Intel Core i3 2328M, 2.20-GHz processor (3.0-MB L3 cache, dual core, 35 W)
693710-001	A	65-W RC V EM HP Smart AC adapter for use with computer models equipped with UMA graphics (for use in China and India only)
693711-001	A	65-W RC V HP Smart AC adapter for use with computer models equipped with UMA graphics (for use in all countries except China and India)

Spare part number	CSR flag	Description
693712-001	A	90-W PFC RC V HP Smart AC adapter for use with computer models equipped with discrete graphics (for use in all countries except China and India)
693713-001	A	90-W PFC RC V EM HP Smart AC adapter for use with computer models equipped with discrete graphics (for use in China and India only)
694693-001	N	System board for use only with computer models without Windows 8 and equipped with an Intel Core i5 or i3 processor and a graphics subsystem with discrete video memory (includes replacement thermal materials)
694693-501	N	System board for use only with computer models with Windows 8 Standard and equipped with an Intel Core i5 or i3 processor and a graphics subsystem with discrete video memory (includes replacement thermal materials)
694693-601	N	System board for use only with computer models with Windows 8 Professional and equipped with an Intel Core i5 or i3 processor and a graphics subsystem with discrete video memory (includes replacement thermal materials)
694694-001	N	System board for use only with computer models without Windows 8 and equipped with an Intel Pentium or Celeron processor and a graphics subsystem with discrete video memory (includes replacement thermal materials)
694694-501	N	System board for use only with computer models with Windows 8 Standard and equipped with an Intel Pentium or Celeron processor and a graphics subsystem with discrete video memory (includes replacement thermal materials)
694694-601	N	System board for use only with computer models with Windows 8 Professional and equipped with an Intel Pentium or Celeron processor and a graphics subsystem with discrete video memory (includes replacement thermal materials)
694746-001	N	35.6-cm (14.0-in), HD, LED, Anti-glare display panel
694747-001	N	HP TrueVision HD webcam/microphone module
698694-001	N	Keyboard for use in the United States (includes keyboard cable)
698694-161	N	Keyboard for use in Latin America (includes keyboard cable)
698694-201	N	Keyboard for use in Brazil (includes keyboard cable)
698694-281	N	Keyboard for use in Thailand (includes keyboard cable)
698694-AB1	N	Keyboard for use in Taiwan (includes keyboard cable)
698694-AD1	N	Keyboard for use in South Korea (includes keyboard cable)
698694-D61	N	Keyboard for use in India (includes keyboard cable)
699547-001	N	Intel Celeron B830, 1.8-GHz processor (2.0-MB L3 cache, dual core, 35 W)
699834-201	A	Atheros HB125 802.11 b/g/n 1×1 WiFi + Bluetooth 4.0 Combo Adapter
700627-001	N	Intel Core i3 3120M, 2.50-GHz processor (3.0-MB L3 cache, dual core, 35 W)
700628-001	N	Intel Pentium 2020M, 2.40-GHz processor (2.0-MB L3 cache, dual core, 35 W)
702756-001	A	Optical drive insert for use in models without an optical drive
704201-001	N	Base enclosure for use in all countries
709848-001	A	Realtek RTL8188EE 802.11bgn Wi-Fi Adapter

Spare part number	CSR flag	Description
711903-001	N	Intel Core i5, 3230M 2.60-GHz processor (3.0-MB L3 cache, dual core, 35 W)
712639-201	A	Atheros AR9485 802.11b/g/n WiFi Adapter for use in Brazil
713162-001	N	Intel Celeron 1000M, 1.8-GHz processor (2.0-MB L3 cache, dual core, 35 W)
713163-001	N	Intel Core i3 3130M, 2.60-GHz processor (3.0-MB L3 cache, dual core, 35 W)
713164-001	N	Intel Pentium 2030M, 2.50-GHz processor (2.0-MB L3 cache, dual core, 35 W)
713165-001	N	Intel Core i3 2348M, 2.30-GHz processor (3.0-MB L3 cache, dual core, 35 W)
713529-001	N	Display enclosure for use in black models (includes Mylar screw covers)
713530-001	N	Top cover for use in black models
720634-001	N	System board for use only with computer models without Windows 8 and equipped with an AMD E2-2000 processor (includes replacement thermal materials)
720634-501	N	System board for use only with computer models with Windows 8 Standard and equipped with an AMD E2-2000 processor (includes replacement thermal materials)
720634-601	N	System board for use only with computer models with Windows 8 Professional and equipped with an AMD E2-2000 processor (includes replacement thermal materials)
720635-001	N	System board for use only with computer models without Windows 8 and equipped with an AMD E1-1500 processor (includes replacement thermal materials)
720635-501	N	System board for use only with computer models with Windows 8 Standard and equipped with an AMD E1-1500 processor (includes replacement thermal materials)
720635-601	N	System board for use only with computer models with Windows 8 Professional and equipped with an AMD E1-1500 processor (includes replacement thermal materials)
730670-001	N	System board for use only with computer models without Windows 8 and equipped with an AMD A6-5200 processor (includes replacement thermal materials)
730670-501	N	System board for use only with computer models with Windows 8 Standard and equipped with an AMD A6-5200 processor (includes replacement thermal materials)
730670-601	N	System board for use only with computer models with Windows 8 Professional and equipped with an AMD A6-5200 processor (includes replacement thermal materials)
730671-001	N	System board for use only with computer models without Windows 8 and equipped with an AMD A4-5000 processor (includes replacement thermal materials)
730671-501	N	System board for use only with computer models with Windows 8 Standard and equipped with an AMD A4-5000 processor (includes replacement thermal materials)
730671-601	N	System board for use only with computer models with Windows 8 Professional and equipped with an AMD A4-5000 processor (includes replacement thermal materials)
747492-001	N	System board for use only with computer models without Windows 8 and equipped with an AMD A60M processor (includes replacement thermal materials)
747492-501	N	System board for use only with computer models with Windows 8 Standard and equipped with an AMD A60M processor (includes replacement thermal materials)
747492-601	N	System board for use only with computer models with Windows 8 Professional and equipped with an AMD A60M processor (includes replacement thermal materials)

Spare part number	CSR flag	Description
733476-001	A	Qualcomm QCA9565 802.11bgn 1x1 Wi-Fi + BT4.0 Combo Adapter
747746-001	N	System board for use only in HP 246 models without Windows 8 for Elcot and Kenya
747746-501	N	System board for use only in HP 246 models with Windows 8 Standard for Elcot and Kenya
747746-601	N	System board for use only in HP 246 models with Windows 8 Professional for Elcot and Kenya
748030-001	N	Display cable for use in HP 246 and HP 455 models without a webcam (includes Mylar screw covers)
748031-001	N	Display bezel for use with HP 246 and HP 455 models without a webcam (includes Mylar screw covers)

4 Removal and replacement procedures

Preliminary replacement requirements

Tools required

You will need the following tools to complete the removal and replacement procedures:

- Flat-bladed screwdriver
- Magnetic screwdriver
- Phillips P0 and P1 screwdrivers

Service considerations

The following sections include some of the considerations that you must keep in mind during disassembly and assembly procedures.

 **NOTE:** As you remove each subassembly from the computer, place the subassembly (and all accompanying screws) away from the work area to prevent damage.

Plastic parts

 **CAUTION:** Using excessive force during disassembly and reassembly can damage plastic parts. Use care when handling the plastic parts. Apply pressure only at the points designated in the maintenance instructions.

Cables and connectors

 **CAUTION:** When servicing the computer, be sure that cables are placed in their proper locations during the reassembly process. Improper cable placement can damage the computer.

Cables must be handled with extreme care to avoid damage. Apply only the tension required to unseat or seat the cables during removal and insertion. Handle cables by the connector whenever possible. In all cases, avoid bending, twisting, or tearing cables. Be sure that cables are routed in such a way that they cannot be caught or snagged by parts being removed or replaced. Handle flex cables with extreme care; these cables tear easily.

Drive handling

⚠ CAUTION: Drives are fragile components that must be handled with care. To prevent damage to the computer, damage to a drive, or loss of information, observe these precautions:

Before removing or inserting a hard drive, shut down the computer. If you are unsure whether the computer is off or in Hibernation, turn the computer on, and then shut it down through the operating system.

Before handling a drive, be sure that you are discharged of static electricity. While handling a drive, avoid touching the connector.

Before removing a diskette drive or optical drive, be sure that a diskette or disc is not in the drive and be sure that the optical drive tray is closed.

Handle drives on surfaces covered with at least one inch of shock-proof foam.

Avoid dropping drives from any height onto any surface.

After removing a hard drive, an optical drive, or a diskette drive, place it in a static-proof bag.

Avoid exposing an internal hard drive to products that have magnetic fields, such as monitors or speakers.

Avoid exposing a drive to temperature extremes or liquids.

If a drive must be mailed, place the drive in a bubble pack mailer or other suitable form of protective packaging and label the package "FRAGILE."

Grounding guidelines

Electrostatic discharge damage

Electronic components are sensitive to electrostatic discharge (ESD). Circuitry design and structure determine the degree of sensitivity. Networks built into many integrated circuits provide some protection, but in many cases, ESD contains enough power to alter device parameters or melt silicon junctions.

A discharge of static electricity from a finger or other conductor can destroy static-sensitive devices or microcircuitry. Even if the spark is neither felt nor heard, damage may have occurred.

An electronic device exposed to ESD may not be affected at all and can work perfectly throughout a normal cycle. Or the device may function normally for a while, then degrade in the internal layers, reducing its life expectancy.

CAUTION: To prevent damage to the computer when you are removing or installing internal components, observe these precautions:

Keep components in their electrostatic-safe containers until you are ready to install them.

Before touching an electronic component, discharge static electricity by using the guidelines described in this section.

Avoid touching pins, leads, and circuitry. Handle electronic components as little as possible.

If you remove a component, place it in an electrostatic-safe container.

The following table shows how humidity affects the electrostatic voltage levels generated by different activities.

CAUTION: A product can be degraded by as little as 700 V.

Typical electrostatic voltage levels			
Event	Relative humidity		
	10%	40%	55%
Walking across carpet	35,000 V	15,000 V	7,500 V
Walking across vinyl floor	12,000 V	5,000 V	3,000 V
Motions of bench worker	6,000 V	800 V	400 V
Removing DIPS from plastic tube	2,000 V	700 V	400 V
Removing DIPS from vinyl tray	11,500 V	4,000 V	2,000 V
Removing DIPS from Styrofoam	14,500 V	5,000 V	3,500 V
Removing bubble pack from PCB	26,500 V	20,000 V	7,000 V
Packing PCBs in foam-lined box	21,000 V	11,000 V	5,000 V

Packaging and transporting guidelines

Follow these grounding guidelines when packaging and transporting equipment:

- To avoid hand contact, transport products in static-safe tubes, bags, or boxes.
- Protect ESD-sensitive parts and assemblies with conductive or approved containers or packaging.
- Keep ESD-sensitive parts in their containers until the parts arrive at static-free workstations.
- Place items on a grounded surface before removing items from their containers.
- Always be properly grounded when touching a component or assembly.
- Store reusable ESD-sensitive parts from assemblies in protective packaging or non-conductive foam.
- Use transporters and conveyors made of antistatic belts and roller bushings. Be sure that mechanized equipment used for moving materials is wired to ground and that proper materials are selected to avoid static charging. When grounding is not possible, use an ionizer to dissipate electric charges.

Workstation guidelines

Follow these grounding workstation guidelines:

- Cover the workstation with approved static-shielding material.
- Use a wrist strap connected to a properly grounded work surface and use properly grounded tools and equipment.
- Use conductive field service tools, such as cutters, screwdrivers, and vacuums.
- When fixtures must directly contact dissipative surfaces, use fixtures made only of static-safe materials.
- Keep the work area free of nonconductive materials, such as ordinary plastic assembly aids and Styrofoam.
- Handle ESD-sensitive components, parts, and assemblies by the case or PCM laminate. Handle these items only at static-free workstations.
- Avoid contact with pins, leads, or circuitry.
- Turn off power and input signals before inserting or removing connectors or test equipment.

Equipment guidelines

Grounding equipment must include either a wrist strap or a foot strap at a grounded workstation.

- When seated, wear a wrist strap connected to a grounded system. Wrist straps are flexible straps with a minimum of one megohm $\pm 10\%$ resistance in the ground cords. To provide proper ground, wear a strap snugly against the skin at all times. On grounded mats with banana-plug connectors, use alligator clips to connect a wrist strap.
- When standing, use foot straps and a grounded floor mat. Foot straps (heel, toe, or boot straps) can be used at standing workstations and are compatible with most types of shoes or boots. On conductive floors or dissipative floor mats, use foot straps on both feet with a minimum of one megohm resistance between the operator and ground. To be effective, the conductive must be worn in contact with the skin.

The following grounding equipment is recommended to prevent electrostatic damage:

- Antistatic tape
- Antistatic smocks, aprons, and sleeve protectors
- Conductive bins and other assembly or soldering aids
- Nonconductive foam
- Conductive tabletop workstations with ground cords of one megohm resistance
- Static-dissipative tables or floor mats with hard ties to the ground
- Field service kits
- Static awareness labels
- Material-handling packages
- Nonconductive plastic bags, tubes, or boxes
- Metal tote boxes
- Electrostatic voltage levels and protective materials

The following table lists the shielding protection provided by antistatic bags and floor mats.

Material	Use	Voltage protection level
Antistatic plastics	Bags	1,500 V
Carbon-loaded plastic	Floor mats	7,500 V
Metallized laminate	Floor mats	5,000 V

Component replacement procedures

This chapter provides removal and replacement procedures.

There are as many as 66 screws that must be removed, replaced, or loosened when servicing the computer. Make special note of each screw's size and location during removal and replacement.

Service tag and PCID label

Service tag

When ordering parts or requesting information, provide the computer serial number and model description provided on the service tag.

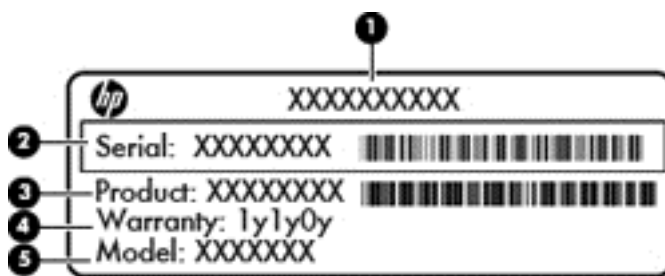

- Product name **(1)**. This is the product name affixed to the front of the computer.
- Serial number (s/n) **(2)**. This is an alphanumeric identifier that is unique to each product.
- Part number/Product number (p/n) **(3)**. This number provides specific information about the product's hardware components. The part number helps a service technician to determine what components and parts are needed.
- Warranty period **(4)**. This number describes the duration (in years) of the warranty period for the computer.
- Model description (select models only) **(5)**. This is the alphanumeric identifier used to locate documents, drivers, and support for the computer.

PCID label

The PCID label provides the information required to properly reset the notebook firmware (BIOS) back to factory shipped specifications when replacing the system board. The label may have a different number of characters depending on the operating system on the computer.

Windows 8 models

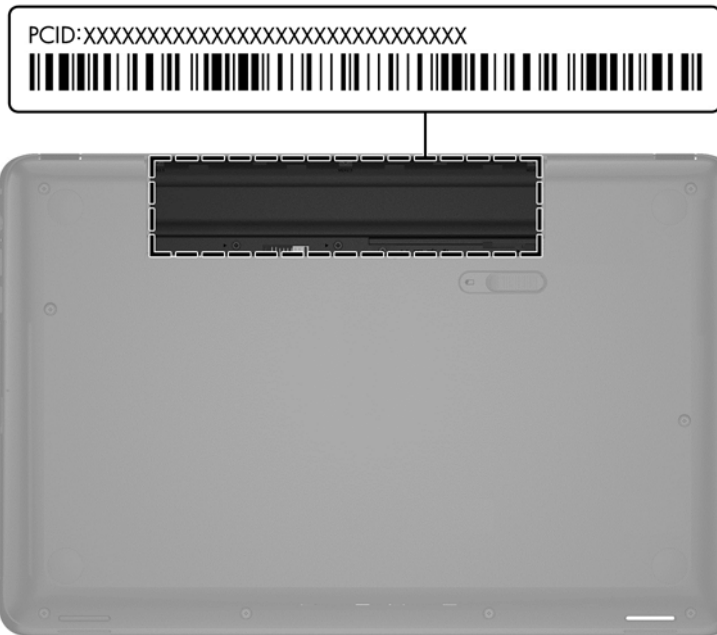

Non-Windows 8 models

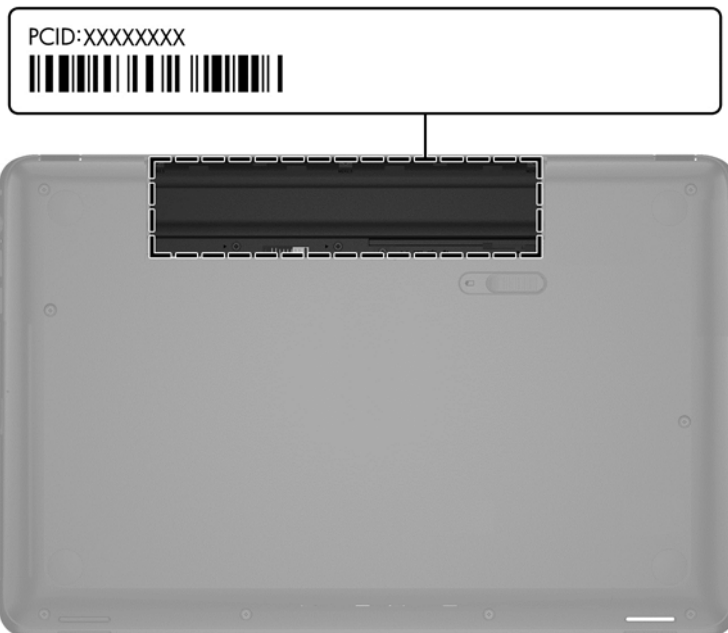

Computer feet

Description	Spare part number
Rubber computer feet	685103-001

The computer feet are adhesive-backed rubber pads. There are 4 rubber feet that attach to the base enclosure in the locations illustrated below.

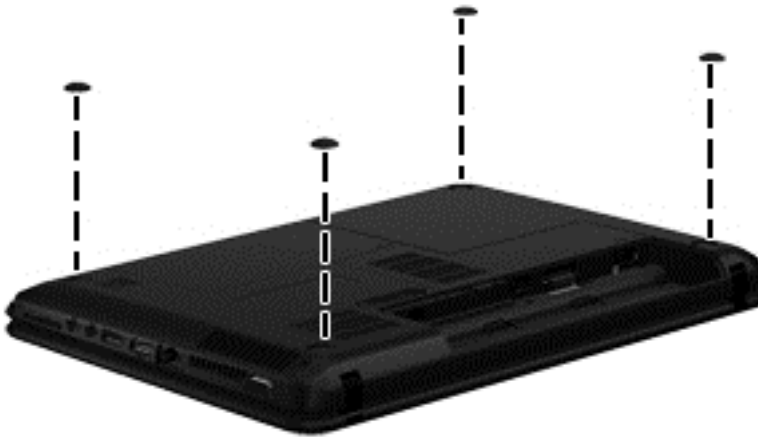

Battery

Description	Spare part number
6-cell, 55-Whr, 2.55-Ah Li-ion battery	593554-001
6-cell, 47-Whr, 2.20-Ah Li-ion battery	593553-001

Before disassembling the computer, follow these steps:

1. Shut down the computer. If you are unsure whether the computer is off or in Hibernation, turn the computer on, and then shut it down through the operating system.
2. Disconnect all external devices connected to the computer.
3. Disconnect the power from the computer by first unplugging the power cord from the AC outlet and then unplugging the AC adapter from the computer.

To remove the battery:

1. Turn the computer upside down on a flat surface.
2. Slide the battery release latch **(1)** to release the battery.

 **NOTE:** The battery release latch automatically returns to its original position.

3. Pivot the battery **(2)** upward and remove it **(3)** from the computer.



To insert the battery:

1. Align the tabs on the rear edge of the battery with the notches on the rear edge of the battery bay.
2. Pivot the front edge of the battery down into the battery bay until it is seated. (The battery release latch will automatically lock into place.)

Display subcomponents (bezel, webcam, panel)

This section describes removing display subcomponents that do not require that you remove the entire display assembly from the computer. You can remove the display bezel, webcam/microphone module, and display panel while the display assembly is still attached to the computer.

To remove the remaining display subcomponents, including the hinge covers, hinges, cable, antennas, and enclosure, you must remove the entire display assembly from the computer. See [Display assembly on page 93](#) for more information about removing the display assembly in its entirety.

Description	Spare part number
35.6-cm (14.0-in), HD, LED, BrightView display panel	685101-001
35.6-cm (14.0-in), HD, LED, Anti-glare display panel	694746-001
Display bezel for use in HP 240 and HP 455 models with a webcam (includes Mylar screw covers)	685081-001
Display bezel for use with HP 246 and HP 455 models without a webcam (includes Mylar screw covers)	748031-001
HP TrueVision HD webcam/microphone module	694747-001
HP VGA webcam/microphone module	685112-001
Rubber display bumpers	685102-001

Before removing the display bezel, webcam/microphone module, and display panel while the display assembly is still attached to the computer, follow these steps:

1. Shut down the computer. If you are unsure whether the computer is off or in Hibernation, turn the computer on, and then shut it down through the operating system.
2. Disconnect all external devices connected to the computer.
3. Disconnect the power from the computer by first unplugging the power cord from the AC outlet and then unplugging the AC adapter from the computer.
4. Remove the battery (see [Battery on page 56](#)).

To remove the display bezel, webcam/microphone module, and display panel while the display assembly is still attached to the computer:

1. Position the computer right-side up with the front toward you, and then open it.
2. Remove the two Mylar screw covers **(1)** and the two Phillips PM2.5×4.0 screws **(2)** that secure the display bezel to the display assembly. The Mylar screw covers are included with the display bezel spare part kit.
3. Flex the inside edges of the top edge, the left and right sides, and the bottom edge of the display bezel until the bezel disengages from the display enclosure.

4. Remove the display bezel **(3)**.



5. To remove the webcam/microphone module:
- a. Remove the two broadhead Phillips PM2.5×2.5 screws **(1)** that secure the display panel and hinges to the enclosure, and then tilt the display panel **(2)** away from the enclosure as far as possible.



- b.** Disconnect the module cable from the module.



- c. Remove the webcam/microphone module. (The module is attached to the display enclosure with double-sided tape.)

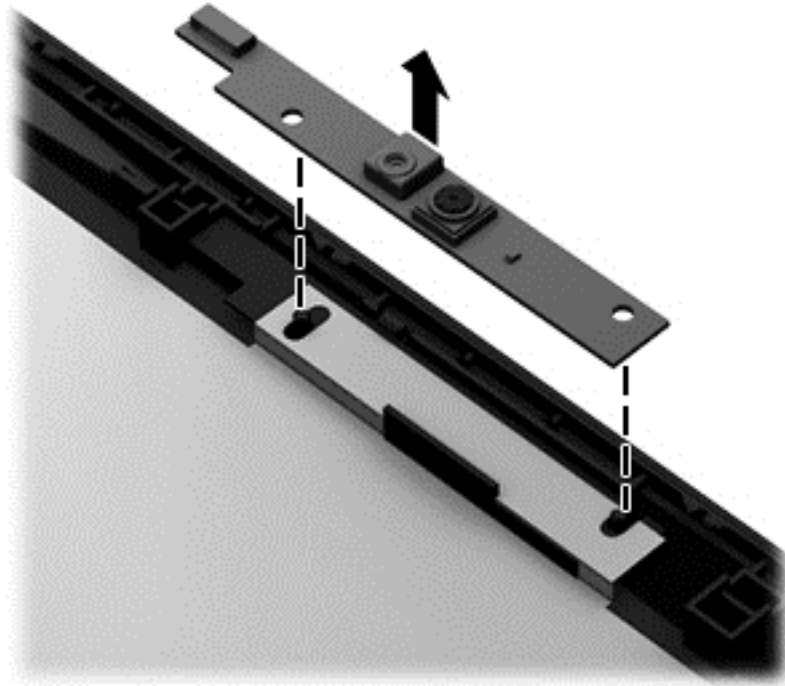

6. To remove the display panel:

- a. Remove the four Phillips PM2.0×3.0 screws **(1)** that secure the display hinges to the display panel, and then tilt the display panel down **(2)** until it rests on the computer.



- b. Release the adhesive strip **(1)** that secures the display panel cable to the display panel, and then disconnect the display panel cable **(2)** from the display panel.

- c. Release the webcam/microphone module cable that is secured to the back of the display panel with adhesive material, and then remove the display panel **(3)**.

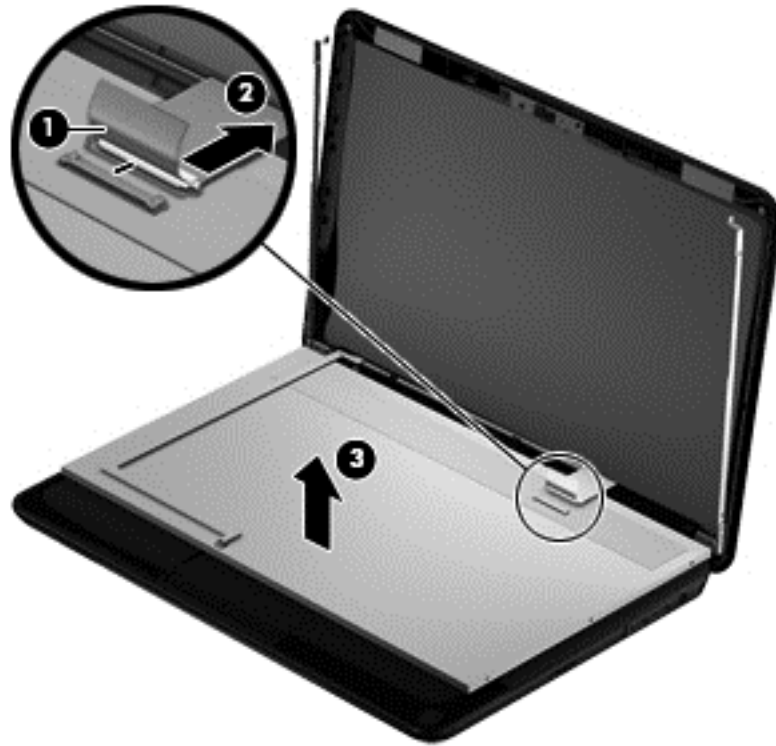

Reverse this procedure to reassemble and install the display bezel, webcam/microphone module, and display panel.

WLAN module

Description	Spare part number
Atheros AR9485 802.11b/g/n 1x1 WiFi Adapter	675794-001
Atheros 9485GN 802.11b/g/n 1x1 WiFi and 3012 Bluetooth 4.0 Combo Adapter	655795-001
Broadcom 4313GN 802.11b/g/n 1x1 WiFi and 20702 Bluetooth 4.0 Combo Adapter	657325-001
Ralink WLAN Ralink Ripple3 RT5390F_802.11 b/g/n 1x1 PCIe HMC	670691-001
Atheros AR9565 802.11bgn 1x1 WiFi + BT4.0 combo Adapter	690019-001
Ralink RT3290LE 802.11bgn 1x1 Wi-Fi and Bluetooth 4.0 Combo Adapter	690020-001
Ralink RT5390R 802.11bgn 1x1 Wi-Fi Adapter	691415-001
Atheros AR9485 802.11b/g/n WiFi Adapter for use in Brazil	712639-201
Atheros HB125 802.11 b/g/n 1x1 WiFi + Bluetooth 4.0 Combo Adapter	699834-201
Realtek RTL8188EE 802.11bgn Wi-Fi Adapter	709848-001
Qualcomm QCA9565 802.11bgn 1x1 Wi-Fi + BT4.0 Combo Adapter	733476-001

CAUTION: To prevent an unresponsive system, replace the wireless module only with a wireless module authorized for use in the computer by the governmental agency that regulates wireless devices in your country or region. If you replace the module and then receive a warning message, remove the module to restore device functionality, and then contact support.

Before removing the WLAN module, follow these steps:

1. Shut down the computer. If you are unsure whether the computer is off or in Hibernation, turn the computer on, and then shut it down through the operating system.
2. Disconnect all external devices connected to the computer.
3. Disconnect the power from the computer by first unplugging the power cord from the AC outlet and then unplugging the AC adapter from the computer.
4. Remove the battery (see [Battery on page 56](#)).

To remove the WLAN module:

1. Loosen the memory module/wireless module compartment cover screw **(1)**, and then lift up on the tab **(2)** and remove the cover **(3)**. The memory module/wireless module compartment cover is available in the Plastics Kit. For more information about the Plastics Kit, see [Plastics Kit on page 39](#).

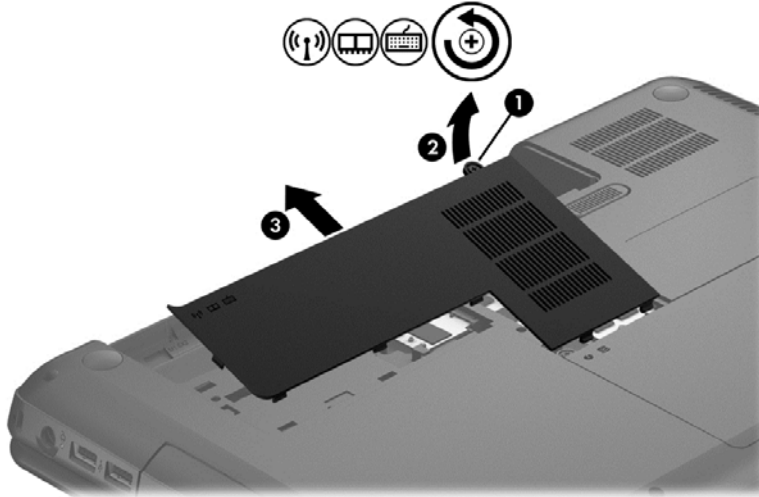



2. Disconnect the WLAN antenna cables **(1)** from the terminals on the WLAN module.

 **NOTE:** The #1 WLAN antenna cable is connected to the WLAN module Main terminal. The #2 WLAN antenna cable is connected to the WLAN module Aux terminal.

3. Remove the Phillips PM2.0×3.0 screw **(2)** that secures the WLAN module to the system board. (The WLAN module tilts up.)

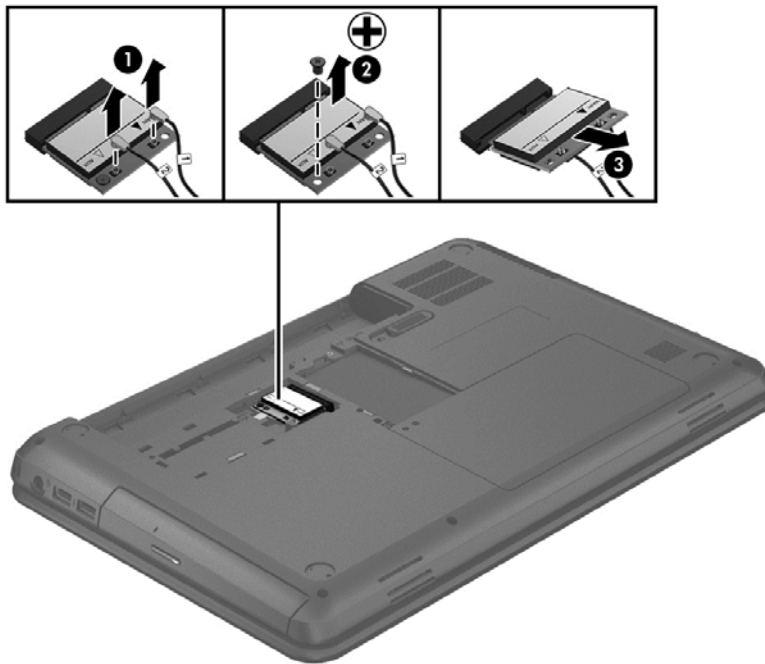
4. Remove the WLAN module by pulling the module away from the slot at an angle **(3)**.



 **NOTE:** If the WLAN antennas are not connected to the terminals on the WLAN module, the protective sleeves must be installed on the antenna connectors, as shown in the following illustration.

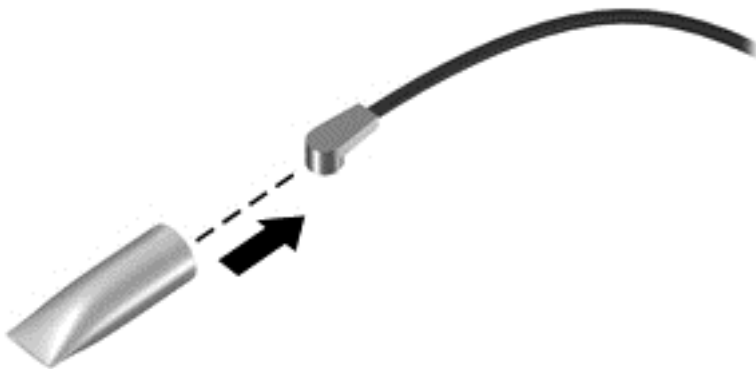

Reverse this procedure to install the WLAN module.

Memory module

Description	Spare part number
4-GB (PC3, 12800, 1600-MHz)	641369-001
2-GB (PC3, 12800, 1600-MHz)	652972-001

Before removing a memory module, follow these steps:

1. Shut down the computer. If you are unsure whether the computer is off or in Hibernation, turn the computer on, and then shut it down through the operating system.
2. Disconnect all external devices connected to the computer.
3. Disconnect the power from the computer by first unplugging the power cord from the AC outlet and then unplugging the AC adapter from the computer.
4. Remove the battery (see [Battery on page 56](#)).
5. Remove the memory module/wireless module compartment cover (see [WLAN module on page 64](#)).

To remove a memory module:

1. Flip up the Mylar sheet protecting the memory module compartment.

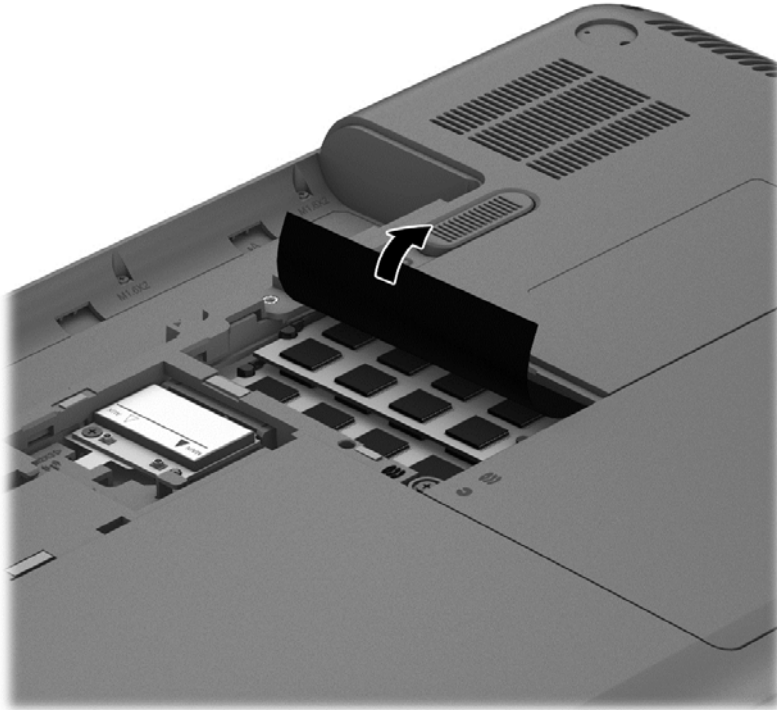

2. Spread the retaining tabs **(1)** on each side of the memory module slot to release the memory module. (The memory module tilts up.)

3. Remove the memory module **(2)** by pulling it away from the slot at an angle.

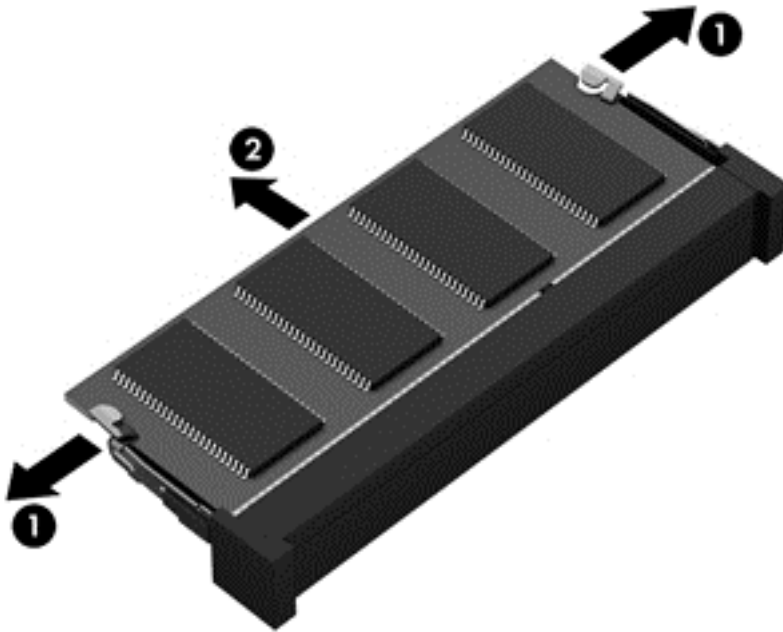

Reverse this procedure to install a memory module.

Hard drive



NOTE: The hard drive spare part kit does not include the hard drive cable or bracket. The hard drive cable and bracket are included in the Hard Drive Hardware Kit.

Description	Spare part number
1-TB, 5400-rpm, 2.5-in	676521-001
750-GB, 5400-rpm, 2.5-in	634250-001
640-GB, 5400-rpm, 2.5-in (HP 240/HP 245 only)	669300-001
500-GB, 7200-rpm, 2.5-in	634925-001
500-GB, 5400-rpm, 2.5-in	669299-001
320-GB, 5400-rpm, 2.5-in	622643-001
Hard Drive Hardware Kit (includes hard drive cable and bracket)	685089-001

Before removing the hard drive, follow these steps:

1. Shut down the computer. If you are unsure whether the computer is off or in Hibernation, turn the computer on, and then shut it down through the operating system.
2. Disconnect all external devices connected to the computer.
3. Disconnect the power from the computer by first unplugging the power cord from the AC outlet and then unplugging the AC adapter from the computer.
4. Remove the battery (see [Battery on page 56](#)).
5. Remove the memory module/wireless module compartment cover (see [WLAN module on page 64](#)).

To remove the hard drive:

1. Loosen the hard drive cover screw **(1)**, and then lift up **(2)** and remove the cover **(3)**. The hard drive compartment cover is available in the Plastics Kit. For more information about the Plastics Kit, see [Plastics Kit on page 39](#).

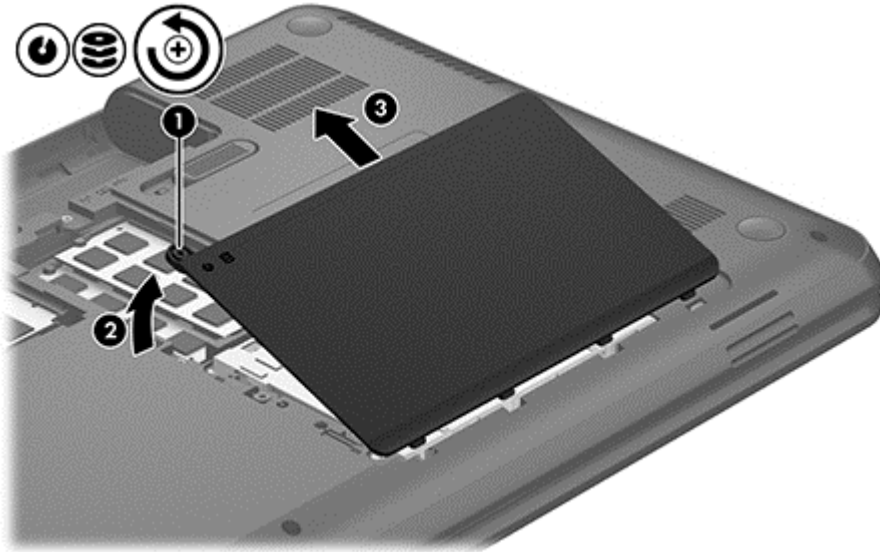

2. Disconnect the hard drive cable **(1)** from the system board.
3. Lift the hard drive **(2)** out of the hard drive bay.

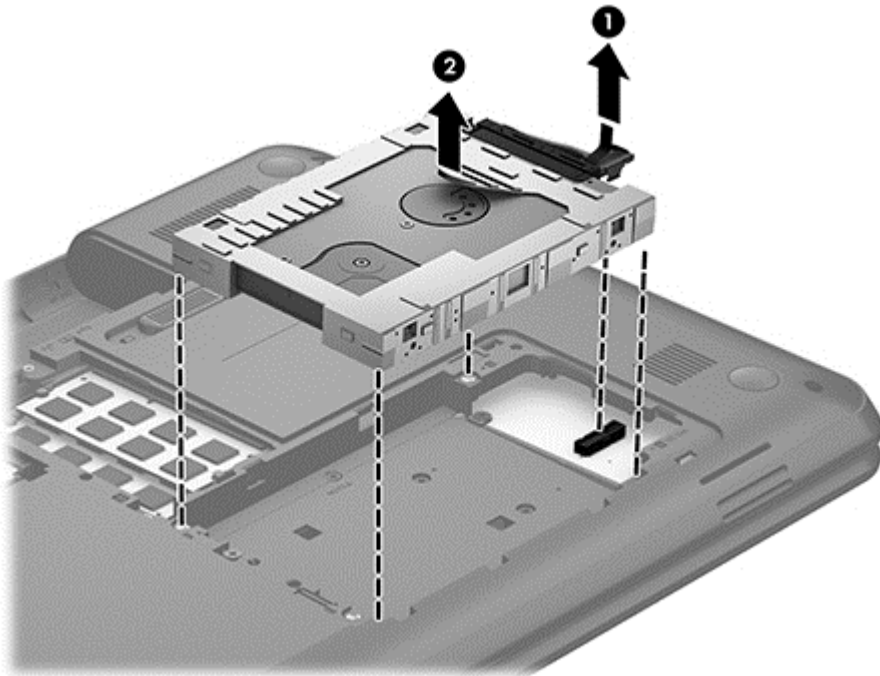

4. Turn over the hard drive, then disconnect the hard drive cable **(1)** from the hard drive.
5. Pull the sides of the hard drive bracket **(2)** out and away from the hard drive.

6. Remove the hard drive (3) from the bracket.

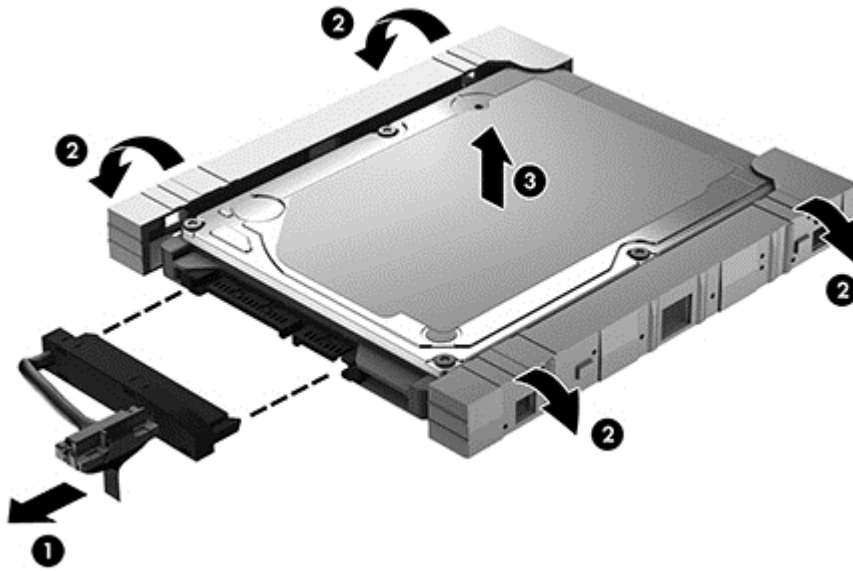

Reverse this procedure to reassemble and install the hard drive.

RTC battery

Description	Spare part number
RTC battery	449137-001

Before removing the RTC battery, follow these steps:

1. Shut down the computer. If you are unsure whether the computer is off or in Hibernation, turn the computer on, and then shut it down through the operating system.
2. Disconnect all external devices connected to the computer.
3. Disconnect the power from the computer by first unplugging the power cord from the AC outlet and then unplugging the AC adapter from the computer.
4. Remove the battery (see [Battery on page 56](#)).
5. Remove the memory module/wireless module compartment cover (see [WLAN module on page 64](#)).
6. Remove the hard drive compartment cover (see [Hard drive on page 70](#)).

To remove the RTC battery:

- ▲ Insert a screwdriver or similar small tool between the battery and the clip that secures it **(1)**, pry the battery up to disengage it from the socket, and then remove the battery **(2)**.

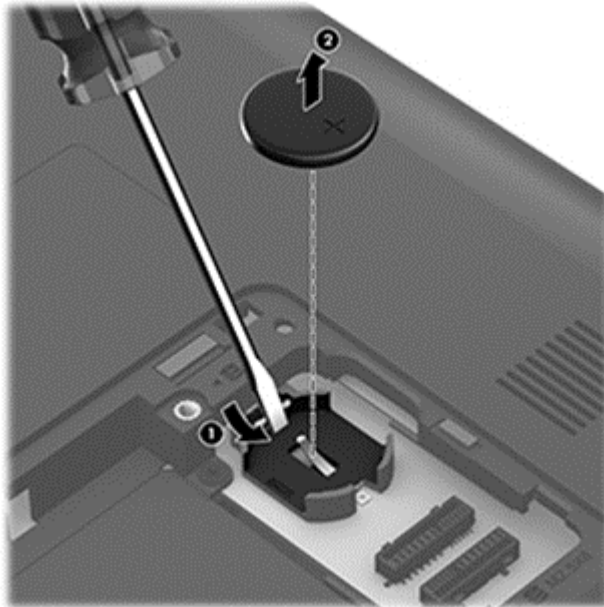

Reverse this procedure to install the RTC battery.

Optical drive

 **NOTE:** The optical drive spare part kit includes the rear optical drive bracket but does not include the optical drive cable or cable bracket. The optical drive cable and cable bracket are included in the optical drive cable kit. See [Optical drive cable on page 107](#) for more information about the optical drive cable and cable bracket.

Description	Spare part number
DVD±RW and CD-RW Super Multi Double-Layer Combo Drive	685096-001
Optical drive insert for use in models without an optical drive	702756-001

Before removing the optical drive, follow these steps:

1. Shut down the computer. If you are unsure whether the computer is off or in Hibernation, turn the computer on, and then shut it down through the operating system.
2. Disconnect all external devices connected to the computer.
3. Disconnect the power from the computer by first unplugging the power cord from the AC outlet and then unplugging the AC adapter from the computer.
4. Remove the battery (see [Battery on page 56](#)).
5. Remove the memory module/wireless module compartment cover (see [WLAN module on page 64](#)).
6. Remove the hard drive (see [Hard drive on page 70](#)).

To remove the optical drive:

1. Remove the Phillips PM2.5×4.0 screw **(1)** that secures the optical drive to the computer.
2. Insert a screwdriver or similar small tool into the hole at the rear of the optical drive bay, and then push the optical drive **(2)** to release it from the bay.

3. Remove the optical drive **(3)** by sliding it out of the optical drive bay.



4. If it is necessary to replace the optical drive bracket on the rear of the optical drive, position the optical drive with the rear panel toward you.
5. Remove the two Phillips PM2.0x3.0 screws **(1)** that secure the bracket to the optical drive.
6. Remove the optical drive bracket **(2)**.

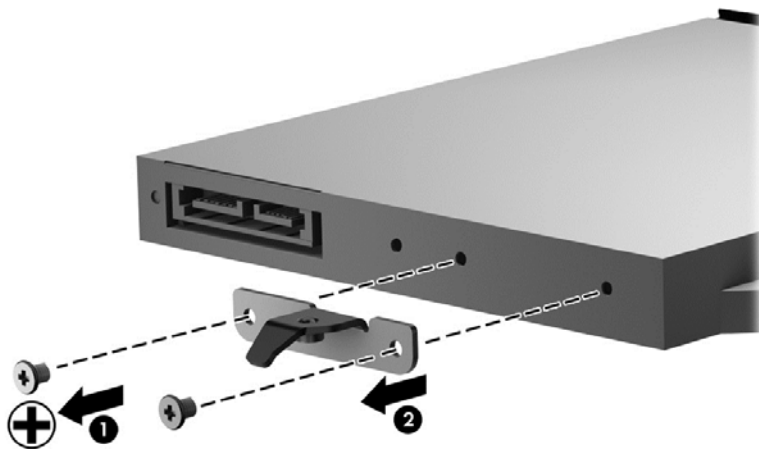

Reverse this procedure to reassemble and install the optical drive.

Keyboard



NOTE: The keyboard spare part kit includes a keyboard cable.

Description	Spare part number
Keyboard for use in Brazil	698694-201
Keyboard for use in India	698694-D61
Keyboard for use in Latin America	698694-161
Keyboard for use in South Korea	698694-AD1
Keyboard for use in Taiwan	698694-AB1
Keyboard for use in Thailand	698694-281
Keyboard for use in the United States	698694-001

Before removing the keyboard, follow these steps:

1. Shut down the computer. If you are unsure whether the computer is off or in Hibernation, turn the computer on, and then shut it down through the operating system.
2. Disconnect all external devices connected to the computer.
3. Disconnect the power from the computer by first unplugging the power cord from the AC outlet and then unplugging the AC adapter from the computer.
4. Remove the battery (see [Battery on page 56](#)).
5. Remove the memory module/wireless module compartment cover (see [WLAN module on page 64](#)).
6. Remove the hard drive compartment cover (see [Hard drive on page 70](#)).

Remove the keyboard:

1. Remove the Phillips PM2.5×4.0 screw that secures the keyboard to the computer just below the WLAN module slot.

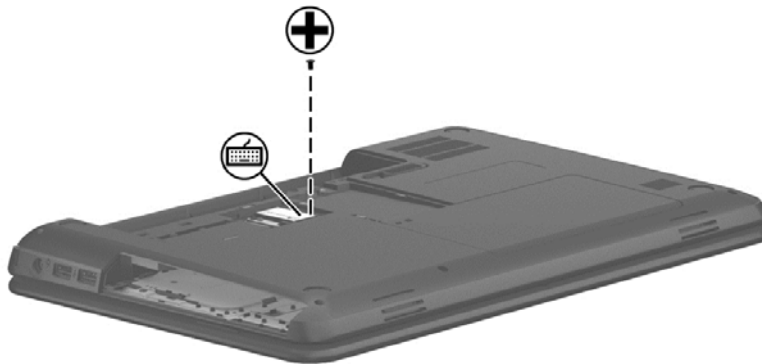

2. Rest and secure the computer on its left side with the bottom toward you, and then partially open the computer.
3. Using a flat-bladed screwdriver or similar tool, push the tabs of the 4 keyboard clips **(1)** that are visible inside the battery bay towards the rear of the computer to loosen the keyboard.
4. Insert a screwdriver or similar small tool into the keyboard release hole **(2)**, and then press on the back of the keyboard until the keyboard disengages from the computer.

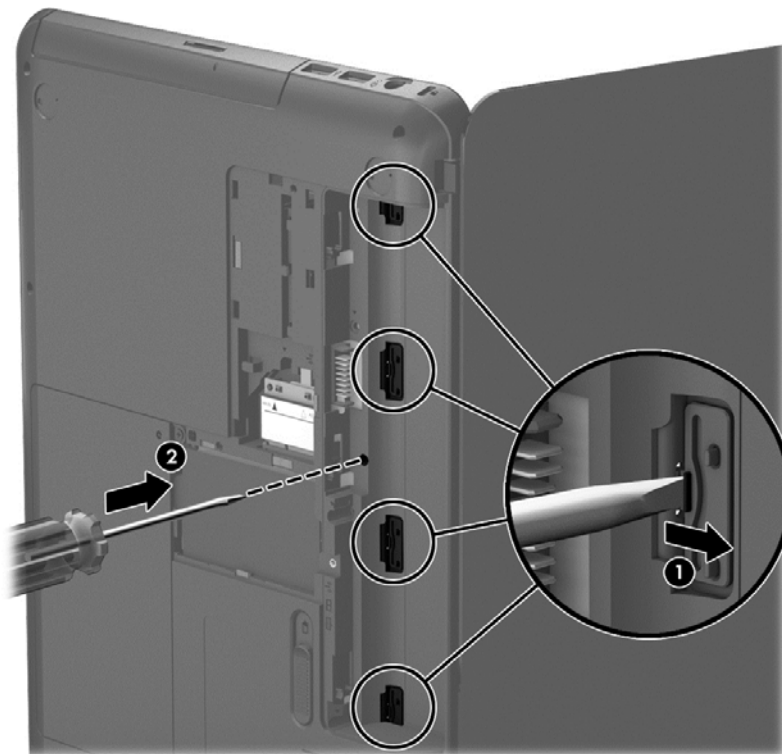

5. Turn the computer right-side up with the front toward you.

6. Lift the rear edge of the keyboard **(1)**, and then swing the keyboard up and forward **(2)** until it rests upside down on the palm rest.



7. Release the zero insertion force (ZIF) connector **(1)** to which the keyboard cable is attached, and then disconnect the keyboard cable **(2)** from the system board.
8. Remove the keyboard **(3)**.



Reverse this procedure to install the keyboard.

Top cover

 **NOTE:** The top cover spare part kit includes the TouchPad. However, it does not include the TouchPad cables. The TouchPad cables are included with the TouchPad button board. For more information on the TouchPad button board, see [TouchPad button board on page 85](#).

Description	Spare part number
Top cover for use in charcoal models	685762-001
Top cover for use in black models	713530-001

Before removing the top cover, follow these steps:

1. Shut down the computer. If you are unsure whether the computer is off or in Hibernation, turn the computer on, and then shut it down through the operating system.
2. Disconnect all external devices connected to the computer.
3. Disconnect the power from the computer by first unplugging the power cord from the AC outlet and then unplugging the AC adapter from the computer.
4. Remove the battery (see [Battery on page 56](#)), and then remove the following components:
 - Memory module/wireless module compartment cover (see [WLAN module on page 64](#))
 - Hard drive (see [Hard drive on page 70](#))
 - Keyboard (see [Keyboard on page 76](#))

 **NOTE:** When replacing the top cover, be sure that the following components are removed from the defective top cover and installed on the replacement top cover:

- Power button board and cable (see [Power button board on page 83](#))
- TouchPad button board and cables (see [TouchPad button board on page 85](#))

To remove the top cover:

1. Close the computer, and then turn the computer upside down with the front toward you.

2. Remove the five Phillips PM2.5×6.0 screws that secure the top cover to the computer.

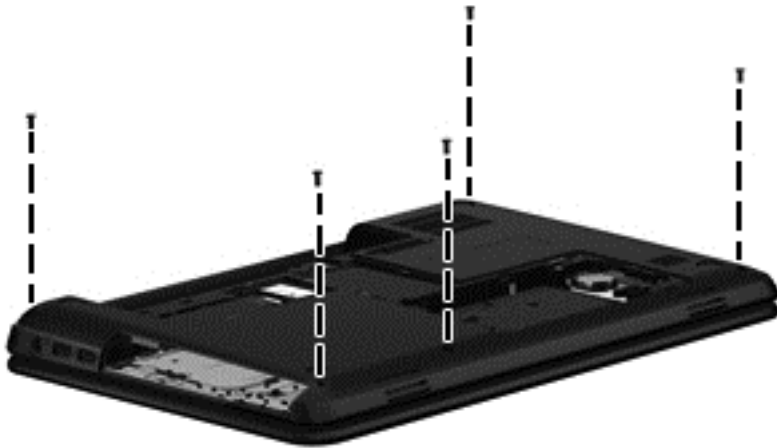

3. Remove the four Phillips PM1.6×2.0 screws (1) and the Phillips PM2.0×3.0 screw (2) that secure the top cover to the computer.

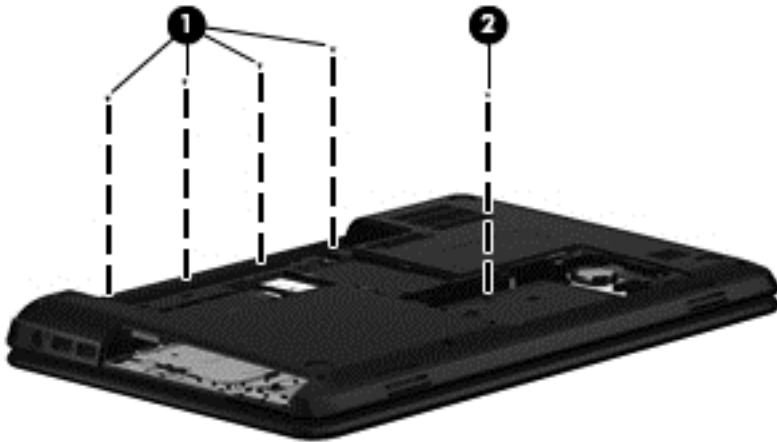

4. Remove the eleven Phillips PM2.5×4.0 screws that secure the top cover to the computer.

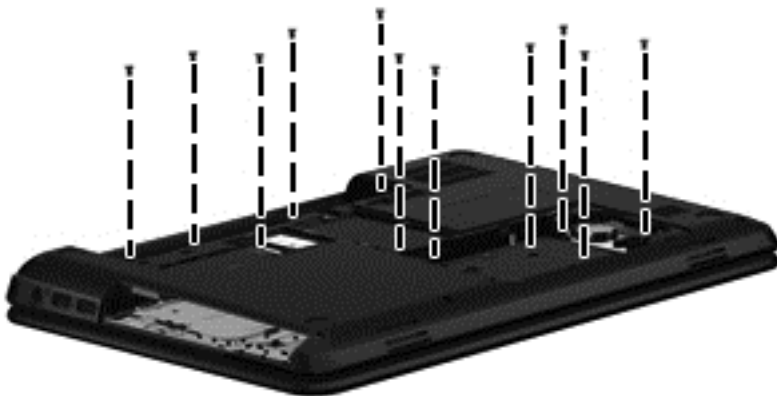

5. Turn the computer right-side up with the front toward you, and then open the computer.

6. Release the ZIF connectors to the power button board cable **(1)** and the TouchPad button board cable **(2)**, and then disconnect the cables from the system board.

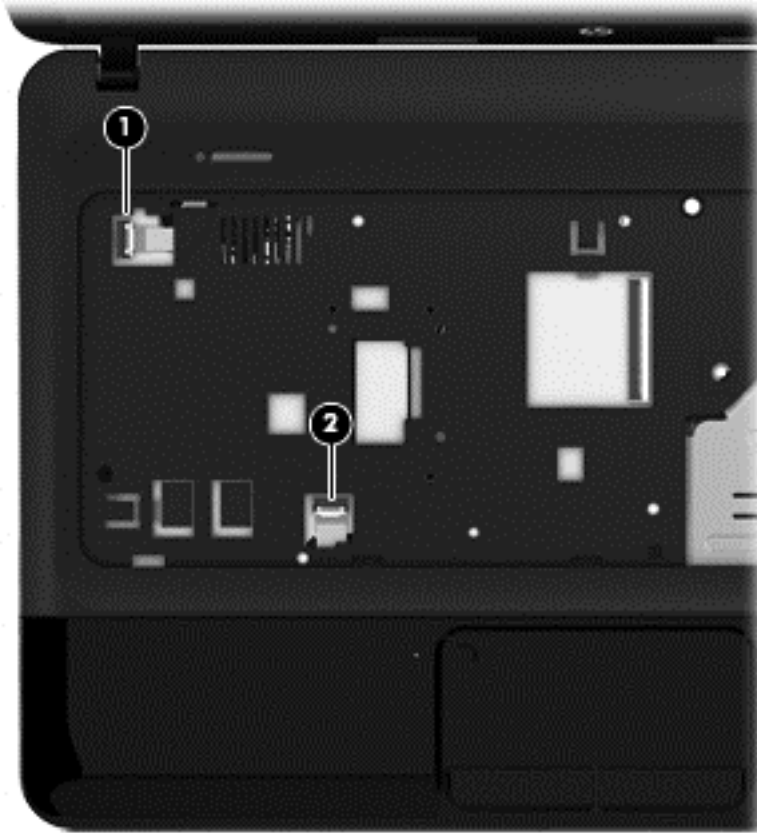

7. Remove the two Phillips PM2.5x6.0 screws that secure the top cover to the computer.



8. Lift the rear edge of the top cover **(1)** until the left and right sides disengage from the base enclosure.

9. Remove the top cover **(2)**.



Reverse this procedure to install the top cover.

Power button board

Description	Spare part number
Power button board (includes cable)	685098-001

Before removing the power button board, follow these steps:

1. Shut down the computer. If you are unsure whether the computer is off or in Hibernation, turn the computer on, and then shut it down through the operating system.
2. Disconnect all external devices connected to the computer.
3. Disconnect the power from the computer by first unplugging the power cord from the AC outlet and then unplugging the AC adapter from the computer.
4. Remove the battery (see [Battery on page 56](#)), and then remove the following components:
 - Memory module/wireless module compartment cover (see [WLAN module on page 64](#))
 - Hard drive (see [Hard drive on page 70](#))
 - Keyboard (see [Keyboard on page 76](#))
 - Top cover (see [Top cover on page 79](#))

To remove the power button board:

1. Turn the top cover upside down with the front toward you.
2. Remove the two Phillips PM2.0×3.0 screws **(1)** that secure the power button board to the top cover.
3. Remove the Mylar sheet covering the power button board **(2)**.

4. Remove the power button board and cable (3).

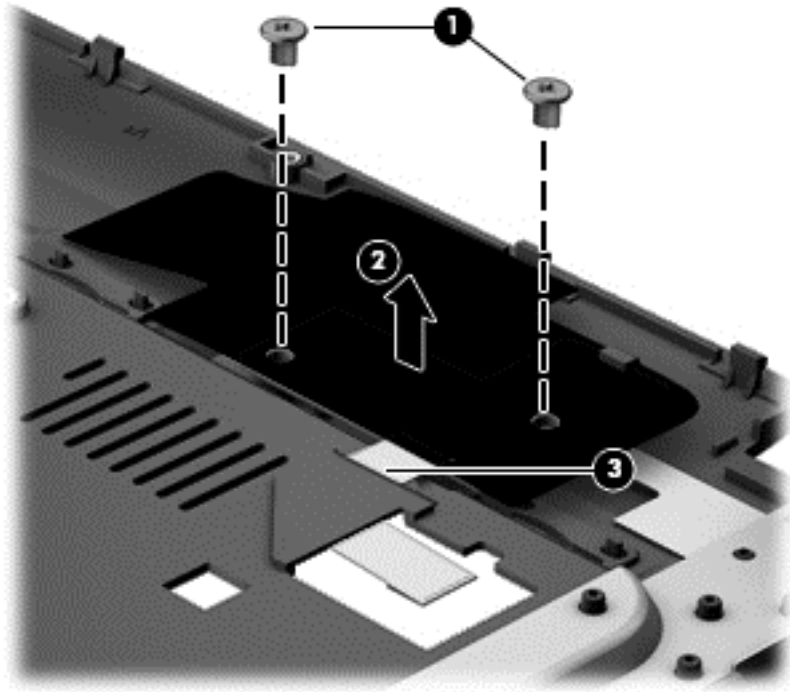

Reverse this procedure to install the power button board and cable.

TouchPad button board

Description	Spare part number
TouchPad button board (includes bracket and cables)	685099-001

Before removing the TouchPad button board, follow these steps:

1. Shut down the computer. If you are unsure whether the computer is off or in Hibernation, turn the computer on, and then shut it down through the operating system.
2. Disconnect all external devices connected to the computer.
3. Disconnect the power from the computer by first unplugging the power cord from the AC outlet and then unplugging the AC adapter from the computer.
4. Remove the battery (see [Battery on page 56](#)), and then remove the following components:
 - Memory module/wireless module compartment cover (see [WLAN module on page 64](#))
 - Hard drive (see [Hard drive on page 70](#))
 - Keyboard (see [Keyboard on page 76](#))
 - Top cover (see [Top cover on page 79](#))

To remove the TouchPad button board:

1. Turn the top cover upside down with the front toward you.
2. Remove the two Phillips PM2.0×3.0 screws **(1)** that secure the TouchPad button board and bracket to the top cover.
3. Remove the bracket **(2)**.
4. Release the ZIF connector to the TouchPad board cable **(3)**, and then disconnect the cable from the TouchPad board. (The TouchPad board is attached to the top cover and cannot be removed.)

5. Remove the TouchPad button board cable (4) from the opening in the top cover, and then remove the TouchPad button board (5).

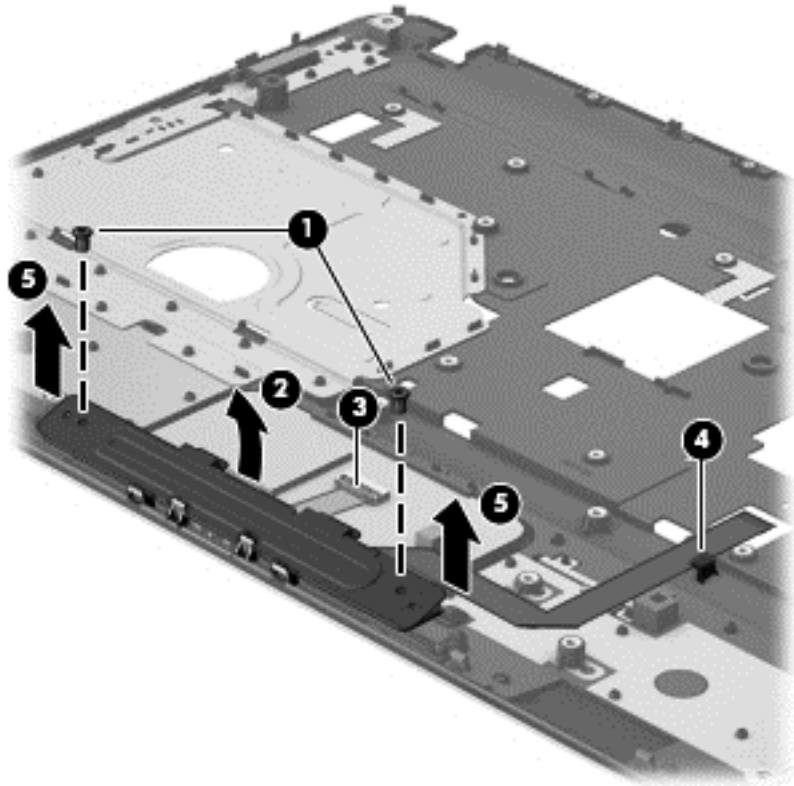

Reverse this procedure to install the TouchPad button board.

Speakers

Description	Spare part number
Speakers (includes left and right speakers and cable)	685106-001

Before removing the speakers, follow these steps:

1. Shut down the computer. If you are unsure whether the computer is off or in Hibernation, turn the computer on, and then shut it down through the operating system.
2. Disconnect all external devices connected to the computer.
3. Disconnect the power from the computer by first unplugging the power cord from the AC outlet and then unplugging the AC adapter from the computer.
4. Remove the battery (see [Battery on page 56](#)), and then remove the following components:
 - Memory module/wireless module compartment cover (see [WLAN module on page 64](#))
 - Hard drive (see [Hard drive on page 70](#))
 - Keyboard (see [Keyboard on page 76](#))
 - Top cover (see [Top cover on page 79](#))

To remove the speakers:

1. Disconnect the speaker cable **(1)** from the system board.
2. To release the left speaker **(2)** out from under the system board, rotate the left speaker **(3)** toward the system board.

3. Remove the speakers (4).

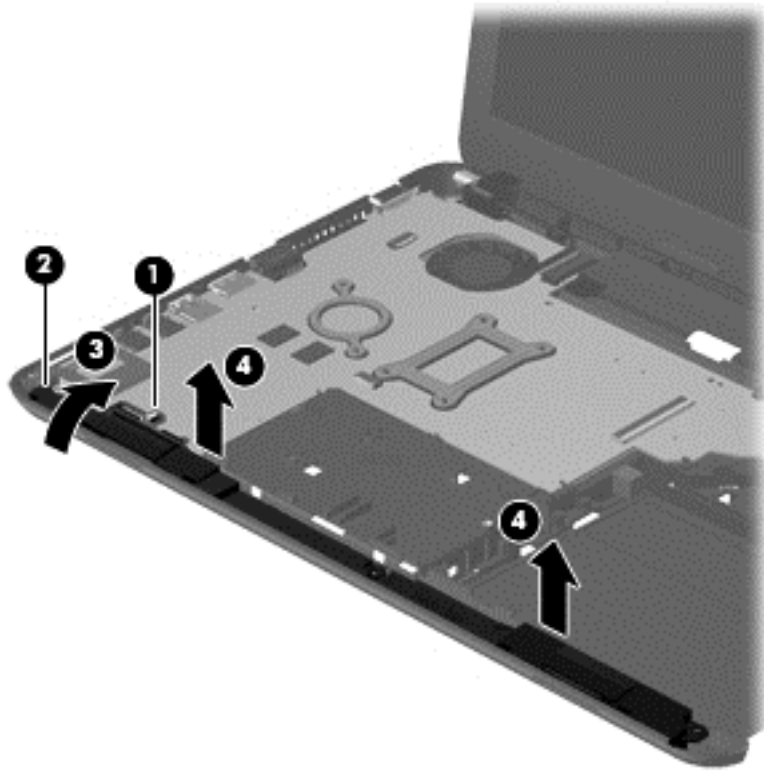

Reverse this procedure to install the speakers.

USB board

Description	Spare part number
USB board (includes cable)	685097-001

Before removing the USB board, follow these steps:

1. Shut down the computer. If you are unsure whether the computer is off or in Hibernation, turn the computer on, and then shut it down through the operating system.
2. Disconnect all external devices connected to the computer.
3. Disconnect the power from the computer by first unplugging the power cord from the AC outlet and then unplugging the AC adapter from the computer.
4. Remove the battery (see [Battery on page 56](#)), and then remove the following components:
 - Memory module/wireless module compartment cover (see [WLAN module on page 64](#))
 - Hard drive (see [Hard drive on page 70](#))
 - Keyboard (see [Keyboard on page 76](#))
 - Top cover (see [Top cover on page 79](#))

To remove the USB board:

1. Release the ZIF connector **(1)** that secures the USB board cable to the system board, and then disconnect the USB board cable.
2. Remove the Phillips PM2.5×4.0 screw **(2)** that secures the USB board to the base enclosure.

3. Remove the USB board **(3)**.

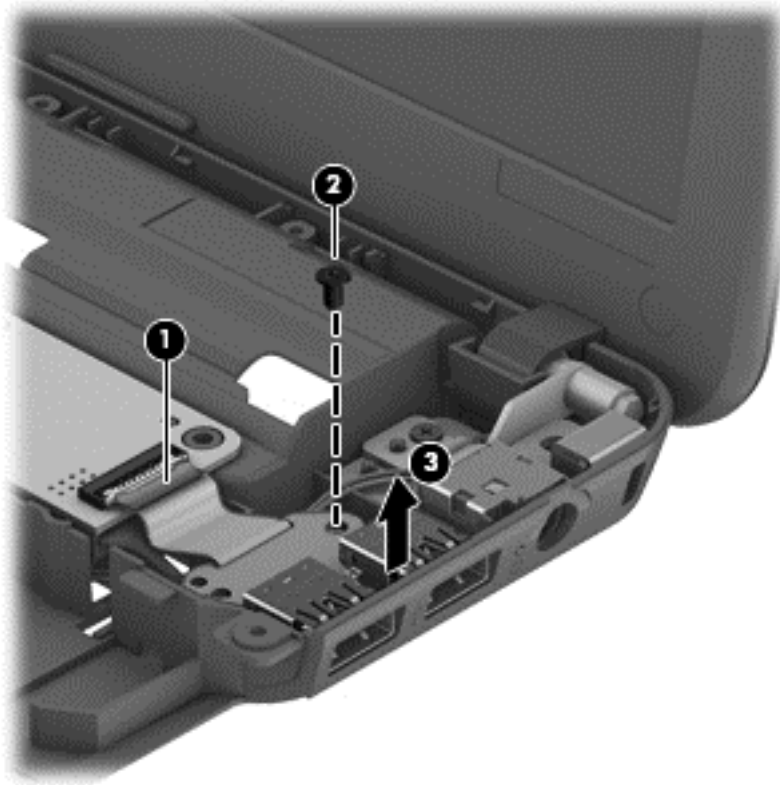

Reverse this procedure to install the USB board.

Power connector cable

Description	Spare part number
Power connector cable	685085-001

Before removing the power connector cable, follow these steps:

1. Shut down the computer. If you are unsure whether the computer is off or in Hibernation, turn the computer on, and then shut it down through the operating system.
2. Disconnect all external devices connected to the computer.
3. Disconnect the power from the computer by first unplugging the power cord from the AC outlet and then unplugging the AC adapter from the computer.
4. Remove the battery (see [Battery on page 56](#)), and then remove the following components:
 - Memory module/wireless module compartment cover (see [WLAN module on page 64](#))
 - Hard drive (see [Hard drive on page 70](#))
 - Keyboard (see [Keyboard on page 76](#))
 - Top cover (see [Top cover on page 79](#))

To remove the power connector cable:

1. Disconnect the power connector cable **(1)** from the system board.
2. Release the power connector cable from the clips **(2)** built into the base enclosure.
3. Remove the tape **(3)** that secures the power connector cable to the base enclosure.

4. Remove the power connector cable **(4)**.

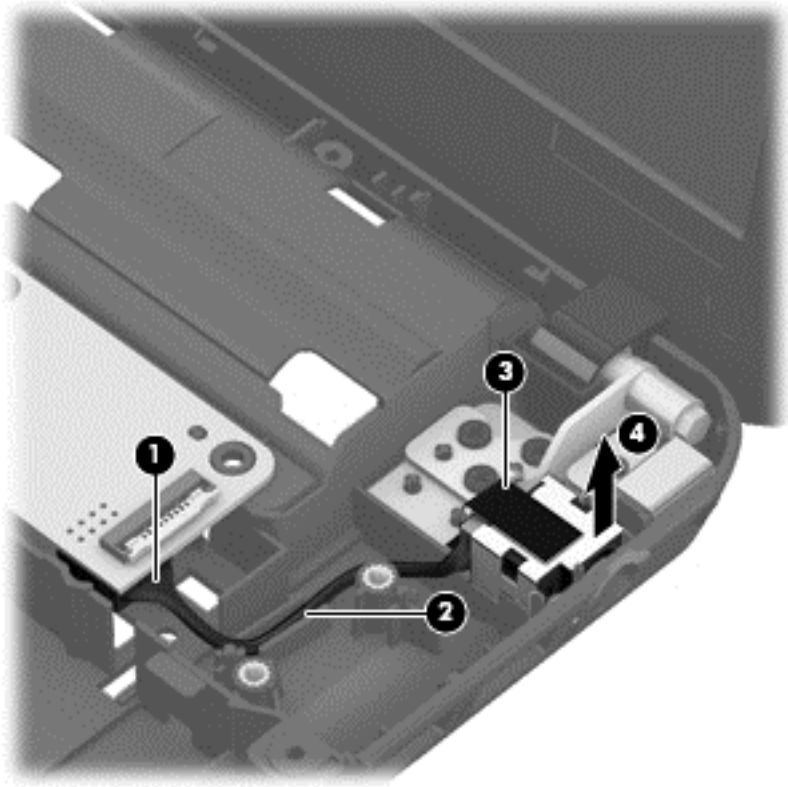

Reverse this procedure to install the power connector cable.

Display assembly

This section describes removing the display assembly in its entirety and disassembling all the display subcomponents.

If you only need to remove the display bezel, webcam/microphone module, or display panel, you do not need to remove the entire display assembly from the computer. See [Display subcomponents \(bezel, webcam, panel\) on page 57](#) for more information about removing the display subcomponents that do not require that you remove the entire display assembly from the computer.

Description	Spare part number
35.6-cm (14.0-in), HD, LED, BrightView display panel	685101-001
35.6-cm (14.0-in), HD, LED, Anti-glare display panel	694746-001
Antennas (includes wireless antenna cables and transceivers; also includes Mylar screw covers)	685076-001
NOTE: Models may have either one or two antennas installed.	
Display bezel for use in HP 240 and HP 455 models with a webcam (includes Mylar screw covers)	685081-001
Display bezel for use with HP 246 and HP 455 models without a webcam (includes Mylar screw covers)	748031-001
Display cable for use in HP 240 and HP 455 models with a webcam (includes Mylar screw covers)	685083-001
Display cable for use in HP 246 and HP 455 models without a webcam (includes Mylar screw covers)	748030-001
Display enclosure for use in charcoal (includes Mylar screw covers)	685756-001
Display enclosure for use in black models (includes Mylar screw covers)	713529-001
Hinge covers (includes Mylar screw covers)	685088-001
Hinges (includes Mylar screw covers)	685090-001
HP TrueVision HD webcam/microphone module	694747-001
HP VGA webcam/microphone module	685112-001
Rubber display bumpers	685102-001

Before removing the display assembly in its entirety, follow these steps:

1. Shut down the computer. If you are unsure whether the computer is off or in Hibernation, turn the computer on, and then shut it down through the operating system.
2. Disconnect all external devices connected to the computer.
3. Disconnect the power from the computer by first unplugging the power cord from the AC outlet and then unplugging the AC adapter from the computer.
4. Remove the battery (see [Battery on page 56](#)).

5. Disconnect the WLAN module antenna cables from the WLAN module (see [WLAN module on page 64](#)).
6. Remove the following components:
 - Hard drive (see [Hard drive on page 70](#))
 - Keyboard (see [Keyboard on page 76](#))
 - Top cover (see [Top cover on page 79](#))
 - USB board (see [USB board on page 89](#))
 - Power connector cable (see [Power connector cable on page 91](#))

To remove the display assembly in its entirety:

1. Disconnect the display panel cable **(1)** from the system board.
2. Release the wireless antenna cables from the clips **(2)** built into the base enclosure.

 **NOTE:** Models may have either one or two antennas installed.

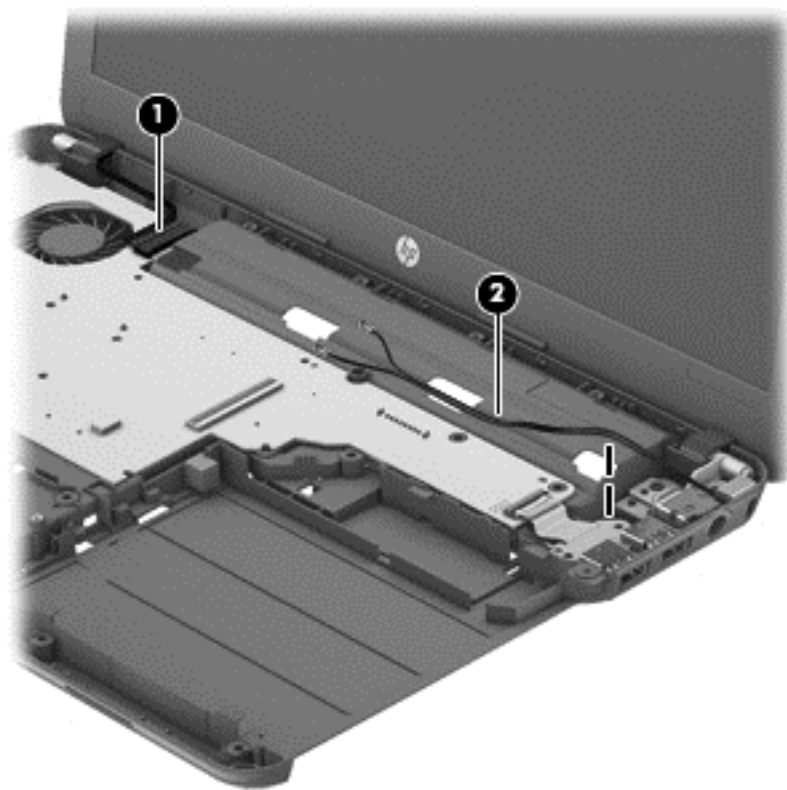

 **CAUTION:** Support the display assembly when removing the following screws. Failure to support the display assembly can result in damage to the display assembly and other computer components.

3. Remove the five Phillips PM2.5×6.0 screws **(1)** that secure the display assembly to the computer.

4. Remove the display assembly **(2)**.

 **NOTE:** Models may have either one or two antennas installed.

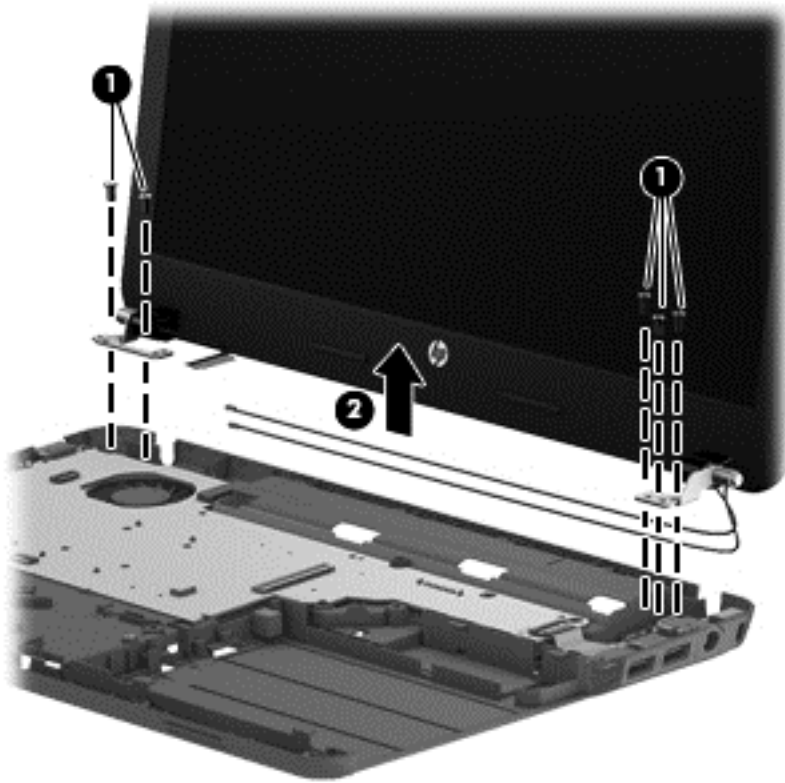

If it is necessary to replace any of the display assembly subcomponents:

1. To remove the display bezel:
 - a. Remove the two Mylar screw covers **(1)** and the two Phillips PM2.5×4.0 screws **(2)** that secure the display bezel to the display assembly. The Mylar screw covers are included with the display bezel spare part kit.
 - b. Flex the inside edges of the top edge **(3)**, the left and right edges **(4)**, and the bottom edge **(5)** of the display bezel until the bezel disengages from the display enclosure.

- c. Remove the display bezel **(6)**.

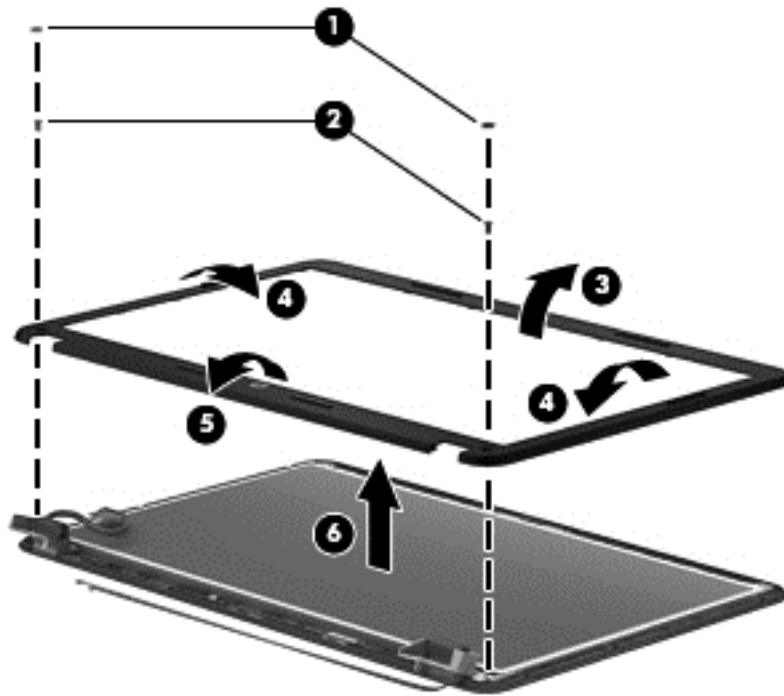

- 2. To remove the webcam/microphone module:
 - a. Position the display assembly with the top edge toward you.
 - b. Remove the two broadhead Phillips PM2.5×2.5 screws **(1)** that secure the display panel to the enclosure.
 - c. Tilt the display panel **(2)** up.

- d. Disconnect the module cable **(3)** from the module.

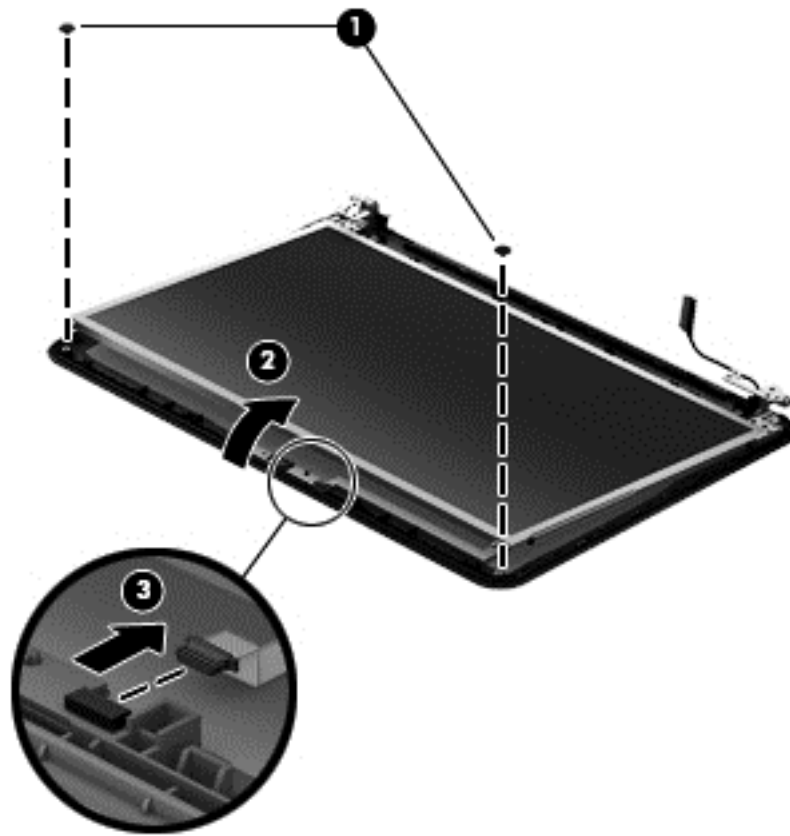

- e. Remove the webcam/microphone module. (The module is attached to the display enclosure with double-sided tape.)

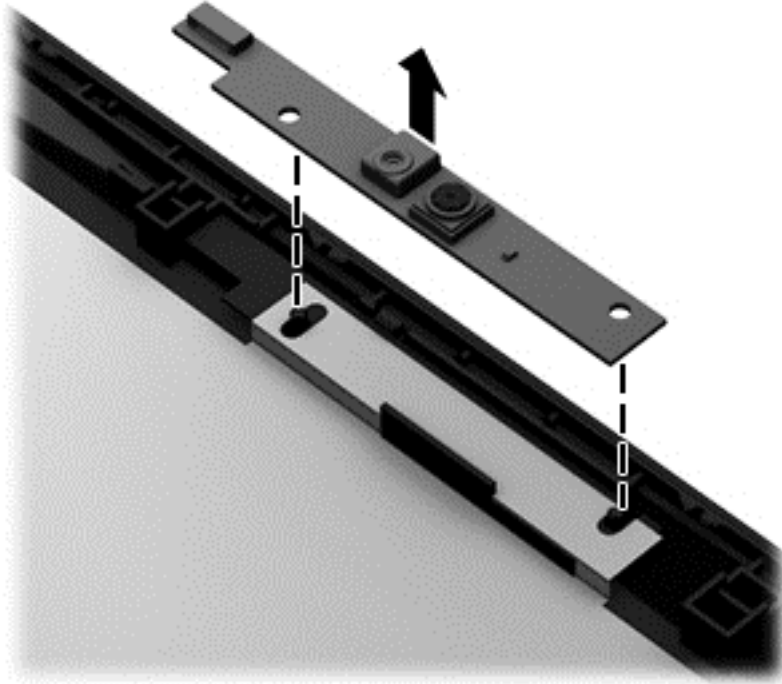

- 3. To remove the hinge covers:
 - a. Position the display assembly with the bottom edge toward you.
 - b. Remove the two Phillips PM2.5×4.0 screws **(1)** that secure the top hinge covers to the display enclosure, and then remove the top hinge covers **(2)**.

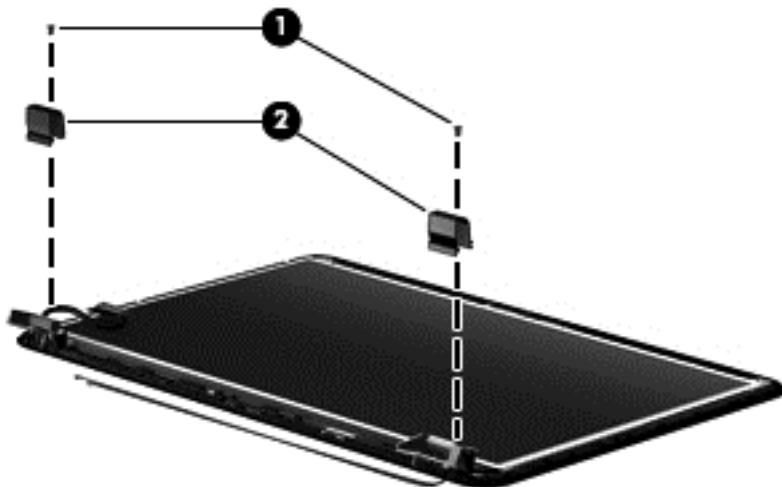

- c. Remove the two Phillips PM2.0×3.0 screws **(1)** that secure the side hinge covers to the display enclosure, and then remove the side hinge covers **(2)**.

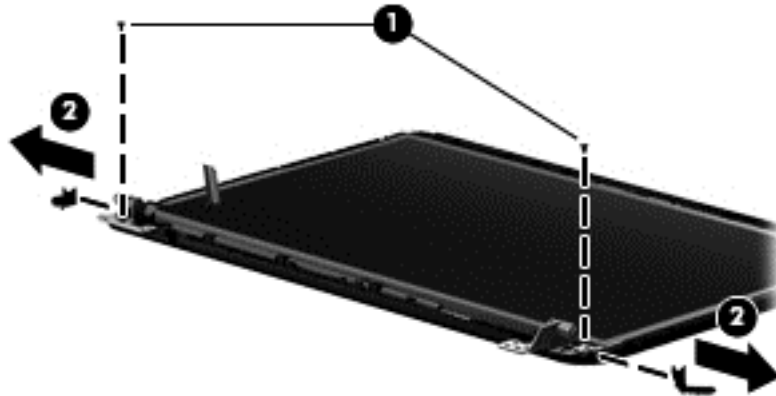

4. To remove the display panel, cable, and hinges:

- a. Position the display assembly with the top edge toward you.
- b. Remove the four Phillips PM2.5×4.0 screws **(1)** that secure the display panel to the enclosure, and then remove the display panel **(2)** from the enclosure.

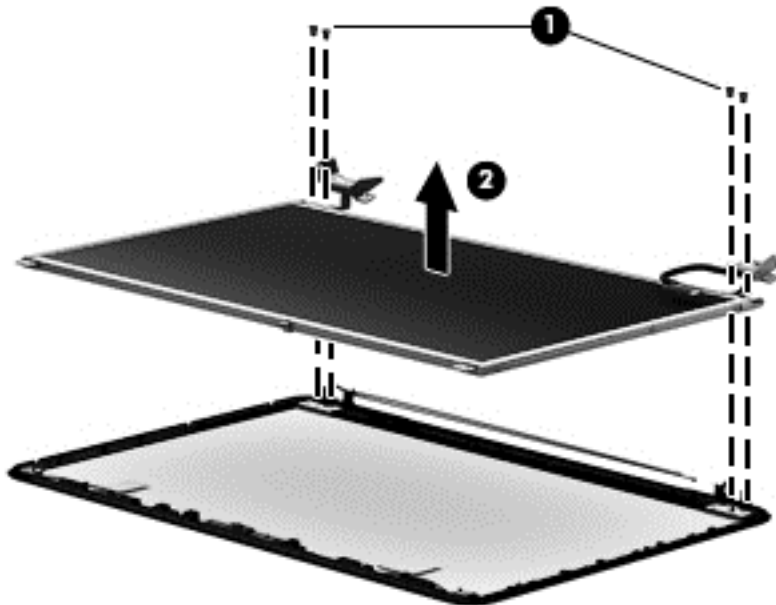

- c. On the back of the display panel, release the adhesive strip **(1)** that secures the display panel cable to the display panel, and then disconnect **(2)** and remove **(3)** the cable.

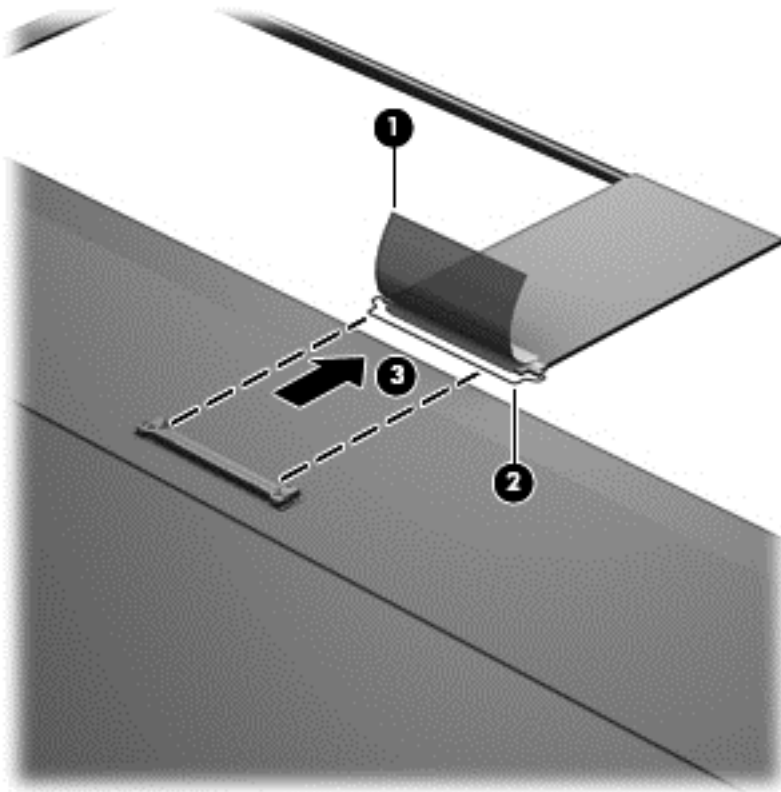

- d. Remove the four Phillips PM2.0x3.0 screws **(1)** that secure the display hinges to the display panel.
- e. Remove the display hinges **(2)**.

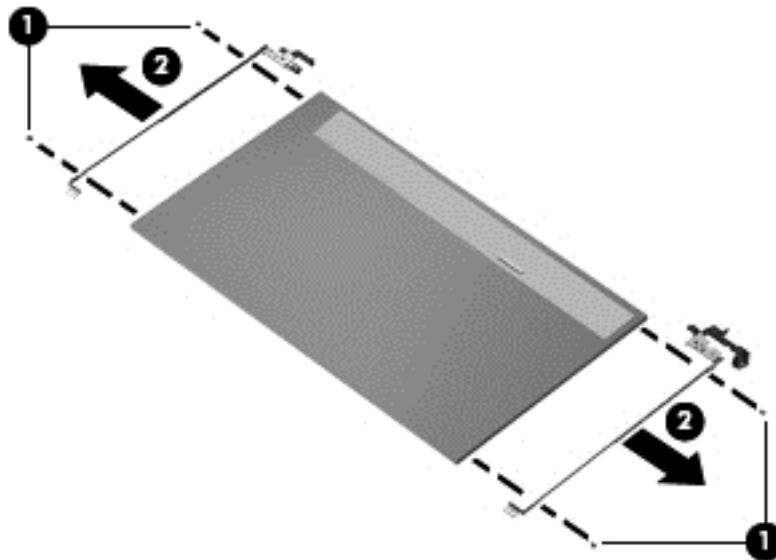

5. To remove the wireless antenna cables and transceivers:
 - a. Position the display assembly with the bottom edge toward you.
 - b. Release the wireless antenna transceivers **(1)** from the display enclosure. (The wireless antenna transceivers are attached to the display enclosure with double-sided tape.)

 **NOTE:** Some models may only have one antenna transceiver.

- c. Release the wireless antenna cables from the clips **(2)** built into the display enclosure.
 - d. Remove the wireless antenna cables and transceivers **(3)**.

 **NOTE:** Models may have either one or two antennas installed.

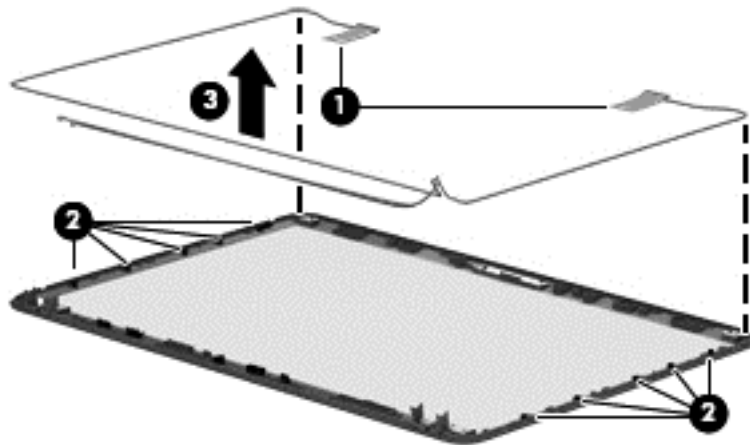

6. If replacing the display enclosure, be sure that the other subcomponents (including the webcam/microphone module, the antenna receivers, and all associated cables and hardware) are transferred to the new enclosure.

Reverse this procedure to reassemble and install the display assembly.

System board



NOTE: The system board spare part kit includes replacement thermal materials (including a thermal pad).

Description	Spare part number
System board for use only with computer models equipped with an AMD E2-2000 processor	
<ul style="list-style-type: none">For use in models without Windows 8	720634-001
<ul style="list-style-type: none">For use in models with Windows 8 Standard	720634-501
<ul style="list-style-type: none">For use in models with Windows 8 Professional	720634-601
System board for use only with computer models equipped with an AMD E2-1800 processor	
<ul style="list-style-type: none">For use in models without Windows 8	688853-001
<ul style="list-style-type: none">For use in models with Windows 8 Standard	688853-501
<ul style="list-style-type: none">For use in models with Windows 8 Professional	688853-601
System board for use only with computer models equipped with an AMD E1-1500 processor	
<ul style="list-style-type: none">For use in models without Windows 8	720635-001
<ul style="list-style-type: none">For use in models with Windows 8 Standard	720635-501
<ul style="list-style-type: none">For use in models with Windows 8 Professional	720635-601
System board for use only with computer models equipped with an AMD E1-1200 processor	
<ul style="list-style-type: none">For use in models without Windows 8	688852-001
<ul style="list-style-type: none">For use in models with Windows 8 Standard	688852-501
<ul style="list-style-type: none">For use in models with Windows 8 Professional	688852-601
System board for use only with computer models equipped with an AMD E300 processor	
<ul style="list-style-type: none">For use in models without Windows 8	688851-001
<ul style="list-style-type: none">For use in models with Windows 8 Standard	688851-501
<ul style="list-style-type: none">For use in models with Windows 8 Professional	688851-601
System board for use only with computer models equipped with an AMD A6-5200 processor	
<ul style="list-style-type: none">For use in models without Windows 8	730670-001
<ul style="list-style-type: none">For use in models with Windows 8 Standard	730670-501
<ul style="list-style-type: none">For use in models with Windows 8 Professional	730670-601
System board for use only with computer models equipped with an AMD A4-5000 processor	
<ul style="list-style-type: none">For use in models without Windows 8	730671-001
<ul style="list-style-type: none">For use in models with Windows 8 Standard	730671-501
<ul style="list-style-type: none">For use in models with Windows 8 Professional	730671-601
System board for use only with computer models equipped with an AMD A60M processor	

Description	Spare part number
<ul style="list-style-type: none"> For use in models without Windows 8 	747492-001
<ul style="list-style-type: none"> For use in models with Windows 8 Standard 	747492-501
<ul style="list-style-type: none"> For use in models with Windows 8 Professional 	747492-601
System board for use only with computer models equipped with an Intel Core i5 or i3 processor and a graphics subsystem with discrete video memory (includes replacement thermal materials)	
<ul style="list-style-type: none"> For use in models without Windows 8 	694693-001
<ul style="list-style-type: none"> For use in models with Windows 8 Standard 	694693-501
<ul style="list-style-type: none"> For use in models with Windows 8 Professional 	694693-601
System board for use only with computer models equipped with an Intel Pentium or Celeron processor and a graphics subsystem with discrete video memory (includes replacement thermal materials)	
<ul style="list-style-type: none"> For use in models without Windows 8 	694694-001
<ul style="list-style-type: none"> For use in models with Windows 8 Standard 	694694-501
<ul style="list-style-type: none"> For use in models with Windows 8 Professional 	694694-601
System board for use only with computer models equipped with an Intel Core i5 or i3 processor and a graphics subsystem with UMA video memory	
<ul style="list-style-type: none"> For use in models without Windows 8 	685761-001
<ul style="list-style-type: none"> For use in models with Windows 8 Standard 	685761-501
<ul style="list-style-type: none"> For use in models with Windows 8 Professional 	685761-601
System board for use only with computer models equipped with an Intel Core i5 or i3 processor and a graphics subsystem with UMA video memory (RCTO system board for use in Brazil and India only)	
<ul style="list-style-type: none"> For use in models without Windows 8 	685107-001
<ul style="list-style-type: none"> For use in models with Windows 8 Standard 	685107-501
<ul style="list-style-type: none"> For use in models with Windows 8 Professional 	685107-601
System board for use only with computer models equipped with an Intel Pentium or Celeron processor and a graphics subsystem with UMA video memory	
<ul style="list-style-type: none"> For use in models without Windows 8 	685768-001
<ul style="list-style-type: none"> For use in models with Windows 8 Standard 	685768-501
<ul style="list-style-type: none"> For use in models with Windows 8 Professional 	685768-601
System board for use only with computer models equipped with an Intel Pentium or Celeron processor and a graphics subsystem with UMA video memory (RCTO system board for use in Brazil and India only)	
<ul style="list-style-type: none"> For use in models without Windows 8 	685783-001
<ul style="list-style-type: none"> For use in models with Windows 8 Standard 	685783-501
<ul style="list-style-type: none"> For use in models with Windows 8 Professional 	685783-601
Thermal pad (for use with all models)	651046-001

Description	Spare part number
System board for use only in HP 246 models for Elcot and Kenya:	
<ul style="list-style-type: none"> For use only in HP 246 models without Windows 8 	747746-001
<ul style="list-style-type: none"> For use only in HP 246 models with Windows 8 Standard 	747746-501
<ul style="list-style-type: none"> For use only in HP 246 models with Windows 8 Professional 	747746-601

Before removing the system board, follow these steps:

1. Shut down the computer. If you are unsure whether the computer is off or in Hibernation, turn the computer on, and then shut it down through the operating system.
2. Disconnect all external devices connected to the computer.
3. Disconnect the power from the computer by first unplugging the power cord from the AC outlet and then unplugging the AC adapter from the computer.
4. Remove the battery (see [Battery on page 56](#)).
5. Remove the following components:
 - WLAN module (see [WLAN module on page 64](#))
 - Hard drive (see [Hard drive on page 70](#))
 - Keyboard (see [Keyboard on page 76](#))
 - Top cover (see [Top cover on page 79](#))
 - Speakers (see [Speakers on page 87](#))
 - USB board (see [USB board on page 89](#))
 - Power connector cable (see [Power connector cable on page 91](#))
6. Disconnect the display cable from the system board (see [Display assembly on page 93](#)).

 **NOTE:** When replacing the system board, be sure that the following components are removed from the defective system board and installed on the replacement system board:

- Memory module (see [Memory module on page 67](#))
- RTC battery (see [RTC battery on page 73](#))
- Fan/heat sink assembly (see [Fan/heat sink assembly on page 109](#))
- Processor (Intel only; see [Processor on page 115](#))

 **NOTE:** AMD processors come soldered to the system board and cannot be removed or replaced.

To remove the system board:

1. Close the computer, turn it upside down, and then disconnect the optical drive connector cable from the system board.

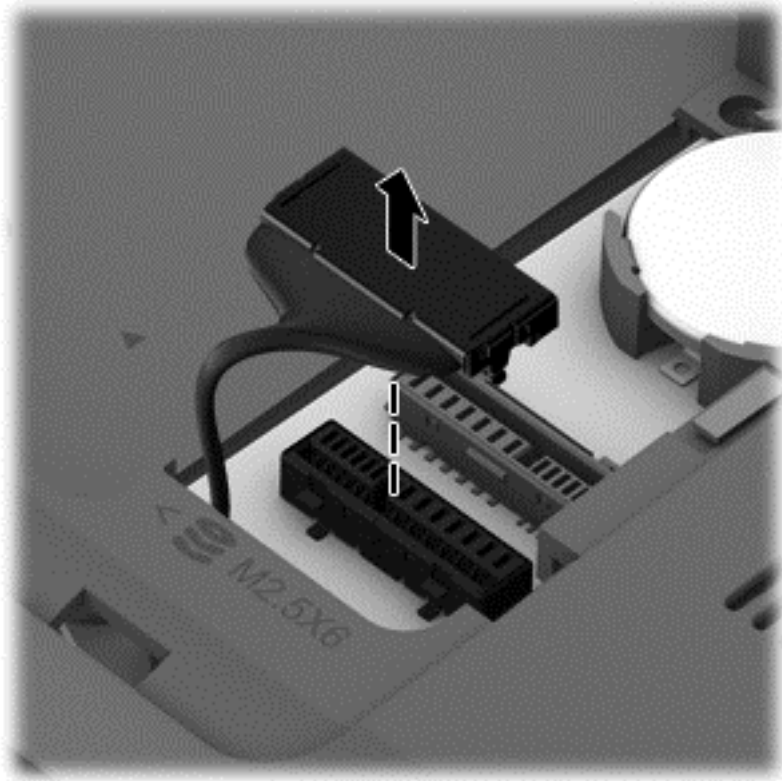

2. Turn the computer back over, open it, and then remove the two Phillips PM2.5×4.0 screws **(1)** that secure the system board to the base enclosure.

3. Tilt the system board up to the left slightly **(2)**, and then remove the system board **(3)**.

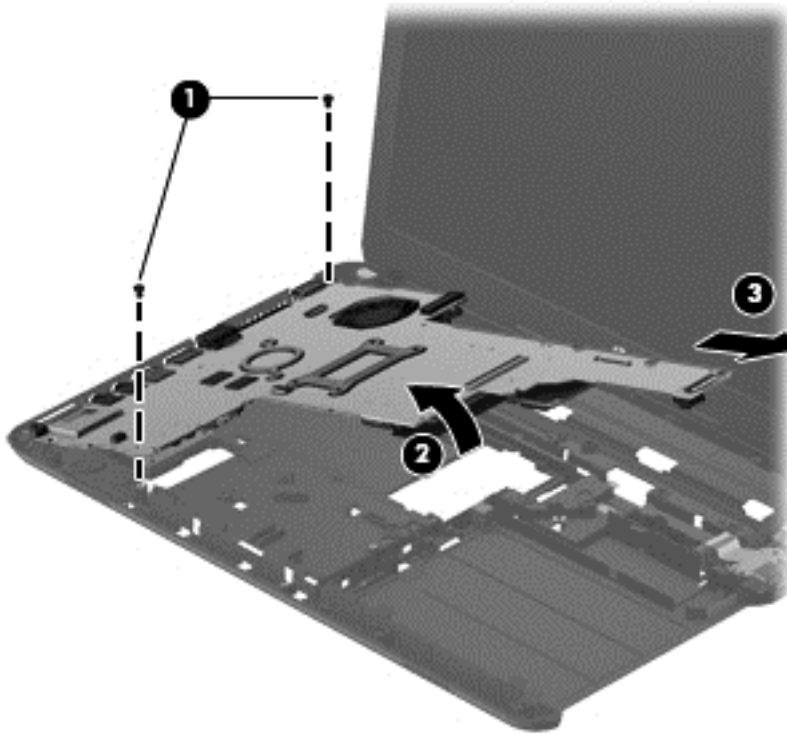

 **NOTE:** A thermal pad services a component on the bottom of the system board. Replacement thermal material is included with all system board spare part kits.

Reverse this procedure to install the system board.

Optical drive cable

Description	Spare part number
Optical drive cable (includes cable bracket)	685084-001

Before removing the optical drive cable, follow these steps:

1. Shut down the computer. If you are unsure whether the computer is off or in Hibernation, turn the computer on, and then shut it down through the operating system.
2. Disconnect all external devices connected to the computer.
3. Disconnect the power from the computer by first unplugging the power cord from the AC outlet and then unplugging the AC adapter from the computer.
4. Remove the battery (see [Battery on page 56](#)), and then remove the following components:
 - WLAN module (see [WLAN module on page 64](#))
 - Hard drive (see [Hard drive on page 70](#))
 - Keyboard (see [Keyboard on page 76](#))
 - Top cover (see [Top cover on page 79](#))
 - Speakers (see [Speakers on page 87](#))
 - USB board (see [USB board on page 89](#))
 - Power connector cable (see [Power connector cable on page 91](#))
 - Display assembly (see [Display assembly on page 93](#))
 - System board (see [System board on page 102](#))

Remove the optical drive cable:

1. Remove the Phillips PM2.0×3.0 screw **(1)** that secures the optical drive cable and cable bracket to the base enclosure.
2. Remove the cable bracket **(2)** and cable **(3)**.

3. Release the optical drive cable from the clips **(4)** built into the base enclosure.

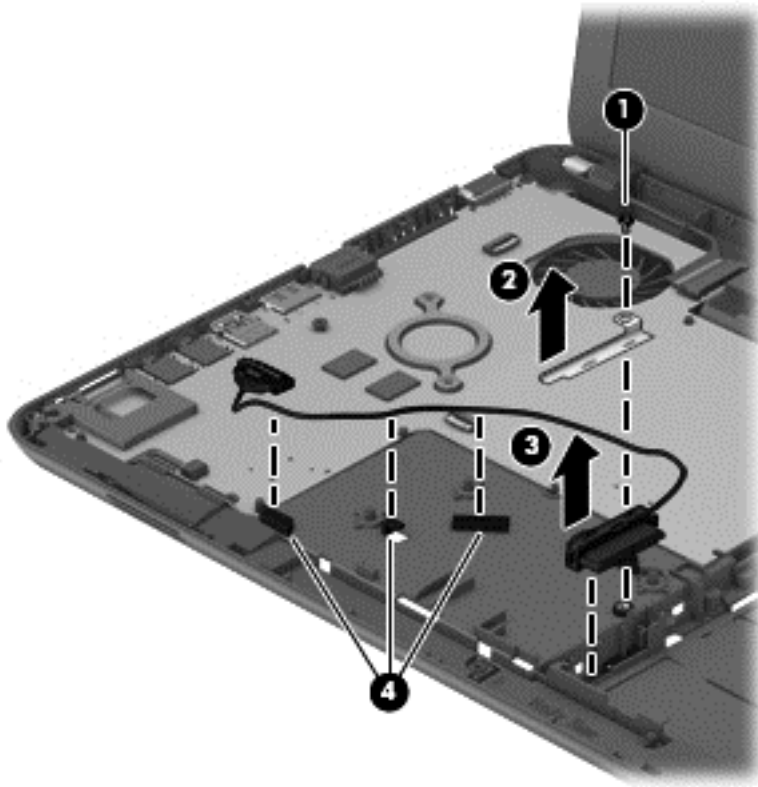

Reverse this procedure to install the optical drive cable.

Fan/heat sink assembly

 **NOTE:** The fan/heat sink assembly spare part kit includes replacement thermal materials.

Description	Spare part number
Fan/heat sink assembly for use only with computer models equipped with an AMD processor	688281-001
Fan/heat sink assembly for use only with computer models equipped with an Intel processor and a graphics subsystem with discrete video memory	685087-001
Fan/heat sink assembly for use only with computer models equipped with an Intel processor and a graphics subsystem with UMA video memory	685086-001

 **NOTE:** To properly ventilate the computer, allow at least **7.6 cm** (3.0 in) of clearance on the left side of the computer. The computer uses an electric fan for ventilation. The fan is controlled by a temperature sensor and is designed to turn on automatically when high temperature conditions exist. These conditions are affected by high external temperatures, system power consumption, power management/battery conservation configurations, battery fast charging, and software requirements. Exhaust air is displaced through the ventilation grill located on the left side of the computer.

Before removing the fan/heat sink assembly, follow these steps:

1. Shut down the computer. If you are unsure whether the computer is off or in Hibernation, turn the computer on, and then shut it down through the operating system.
2. Disconnect all external devices connected to the computer.
3. Disconnect the power from the computer by first unplugging the power cord from the AC outlet and then unplugging the AC adapter from the computer.
4. Remove the battery (see [Battery on page 56](#)), and then remove the following components:
 - WLAN module (see [WLAN module on page 64](#))
 - Hard drive (see [Hard drive on page 70](#))
 - Keyboard (see [Keyboard on page 76](#))
 - Top cover (see [Top cover on page 79](#))
 - Speakers (see [Speakers on page 87](#))
 - USB board (see [USB board on page 89](#))
 - Power connector cable (see [Power connector cable on page 91](#))
 - Display assembly (see [Display assembly on page 93](#))
 - System board (see [System board on page 102](#))

To remove the fan/heat sink assembly:

1. Disconnect the fan cable **(1)** from the system board.
2. Loosen the screws on the heat sink **(2)** that secure the fan/heat sink assembly to the system board.

 **NOTE:** The number of screws used to secure the fan/heat sink assembly to the system board varies by computer model.

3. Remove the Phillips PM2.0×3.0 screw **(3)** that secures the fan/heat sink assembly to the system board.
4. Remove the fan/heat sink assembly **(4)**.

 **NOTE:** Due to the adhesive quality of the thermal material located between the heat sink and system board components, it may be necessary to move the heat sink from side to side to detach it.

 **NOTE:** The following illustration shows the fan/heat sink assembly removal process on a computer model equipped with an AMD processor.

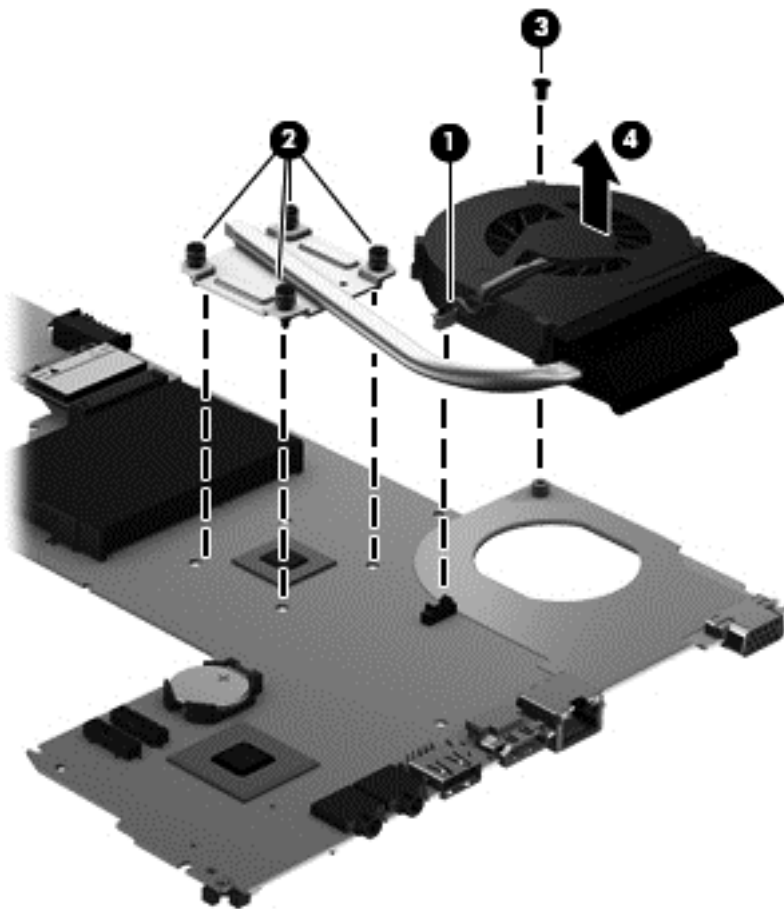

 **NOTE:** The following illustration shows the fan/heat sink assembly removal process on a computer model equipped with an Intel processor and a graphics subsystem with discrete memory.

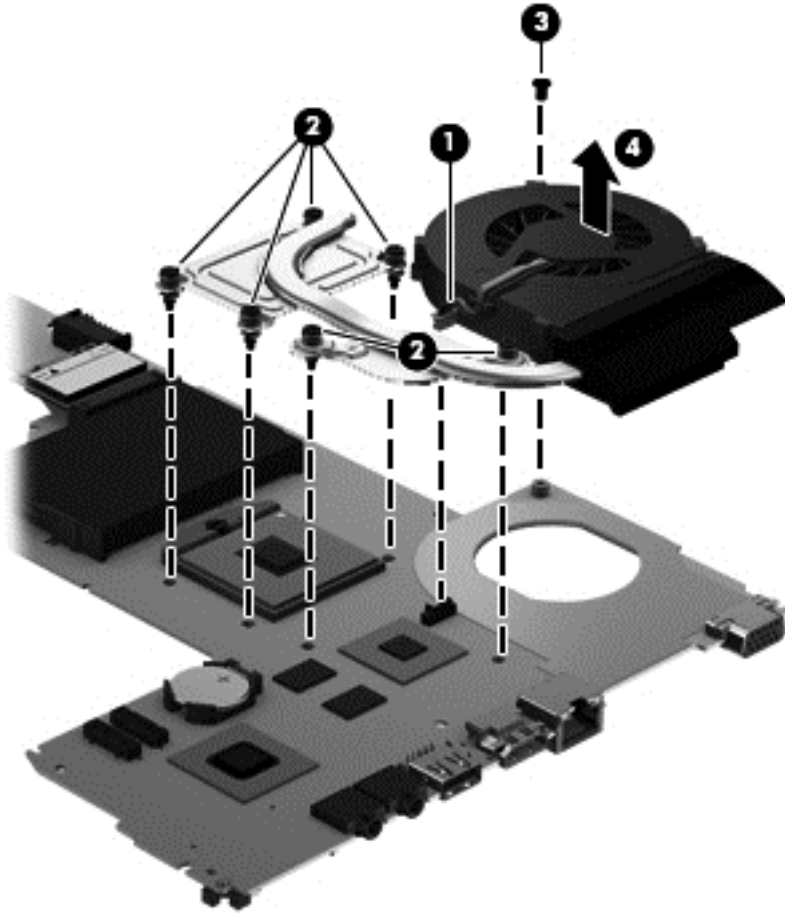

 **NOTE:** The following illustration shows the fan/heat sink assembly removal process on a computer model equipped with an Intel processor and a graphics subsystem with UMA memory.

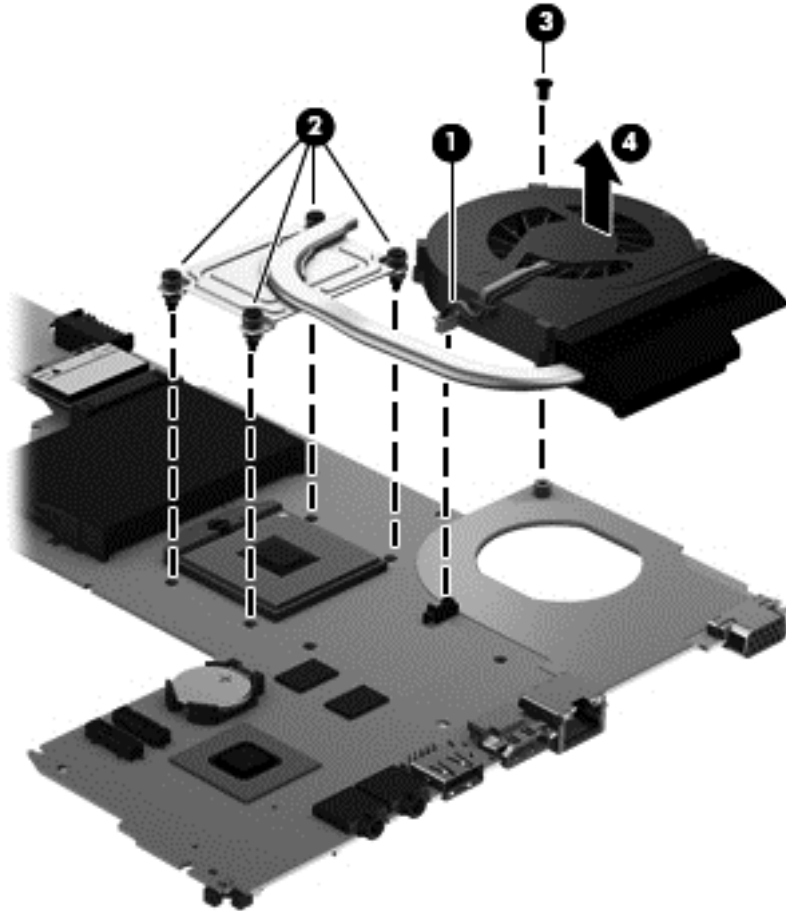

The thermal material must be thoroughly cleaned from the surfaces of the heat sink and the system board components each time the heat sink is removed. Replacement thermal materials are included with the fan/heat sink assembly, processor, and system board spare part kits.

 **NOTE:** The following illustration shows the replacement thermal material locations on a computer model equipped with an AMD processor.

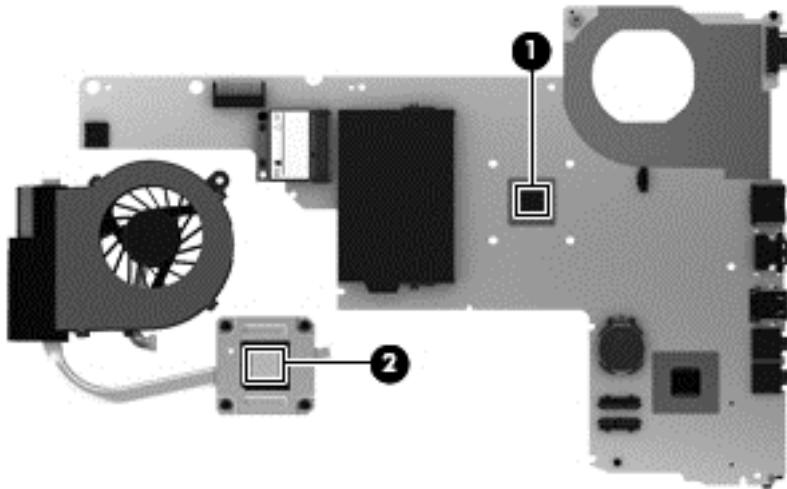

- Thermal paste is used on the processor **(1)** and the heat sink section **(2)** that services it

 **NOTE:** The following illustration shows the replacement thermal material locations on a computer model equipped with an Intel processor and a graphics subsystem with discrete memory.

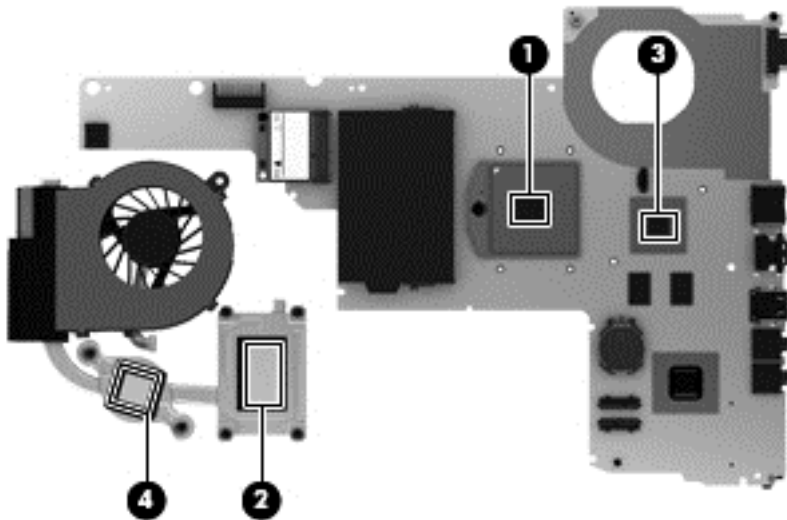

- Thermal paste is used on the processor **(1)** and the heat sink section **(2)** that services it
- Thermal paste is used on the graphics subsystem chip **(3)** and the heat sink section **(4)** that services it

 **NOTE:** The following illustration shows the replacement thermal material locations on a computer model equipped with an Intel processor and a graphics subsystem with UMA memory.

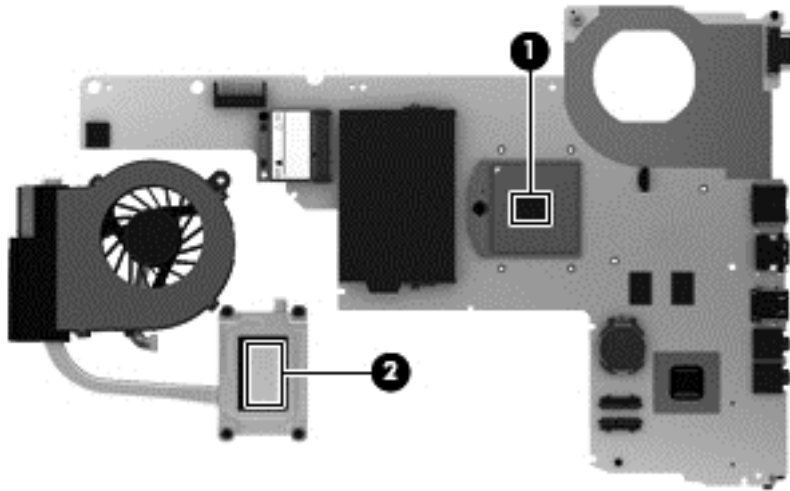

- Thermal paste is used on the processor **(1)** and the heat sink section **(2)** that services it. Reverse this procedure to reassemble and install the fan/heat sink assembly.

Processor

 **NOTE:** This section applies only to computer models equipped with an Intel processor. AMD processors come soldered to the system board and cannot be removed or replaced.

 **NOTE:** The processor spare part kit includes replacement thermal materials.

Description	Spare part number
Intel Core i5 processors (3.0-MB L3 cache, dual core, 35 W):	
3230M 2.60-GHz processor	711903-001
3210 2.50-GHz processor	680645-001
2450 2.50-GHz processor	676359-001
Intel Core i3 processors (3.0-MB L3 cache, dual core, 35 W):	
3130M 2.60-GHz processor	713163-001
3120M 2.50-GHz processor	700627-001
3110M 2.40-GHz processor	682417-001
2370M 2.40-GHz processor	677152-001
2350M 2.30-GHz processor	653340-001
2348M 2.30-GHz processor	713165-001
2328M 2.20-GHz processor	693542-001
Intel Pentium processors (2.0-MB L3 cache, dual core, 35 W):	
2030M 2.50-GHz processor	713164-001
2020M 2.40-GHz processor	700628-001
B980 2.40-GHz processor	692428-001
B970 2.30-GHz processor	676785-001
B960 2.20-GHz processor	664662-001
B950 2.10-GHz processor	653338-001
Intel Celeron processors (2.0-MB L3 cache, dual core, 35 W):	
1000M 1.8-GHz processor	713162-001
B830 1.8-GHz processor	699547-001
B820 1.7-GHz processor	690537-001
B815 1.6-GHz processor	677153-001
B730 1.8-GHz processor	690536-001

Before removing the processor, follow these steps:

- 1.** Shut down the computer. If you are unsure whether the computer is off or in Hibernation, turn the computer on, and then shut it down through the operating system.
- 2.** Disconnect all external devices connected to the computer.
- 3.** Disconnect the power from the computer by first unplugging the power cord from the AC outlet and then unplugging the AC adapter from the computer.
- 4.** Remove the battery (see [Battery on page 56](#)), and then remove the following components:
 - WLAN module (see [WLAN module on page 64](#))
 - Hard drive (see [Hard drive on page 70](#))
 - Keyboard (see [Keyboard on page 76](#))
 - Top cover (see [Top cover on page 79](#))
 - Speakers (see [Speakers on page 87](#))
 - USB board (see [USB board on page 89](#))
 - Power connector cable (see [Power connector cable on page 91](#))
 - Display assembly (see [Display assembly on page 93](#))
 - System board (see [System board on page 102](#))
 - Fan/heat sink assembly (see [Fan/heat sink assembly on page 109](#))

To remove the processor:

- 1.** Use a flat-bladed screw driver **(1)** to turn the processor locking screw one-half turn counterclockwise **(2)** until you hear a click.

2. Lift the processor **(3)** straight up, and then remove it.

 **NOTE:** The gold triangle **(4)** on the processor must be aligned with the triangle icon embossed on the processor socket when you install the processor.

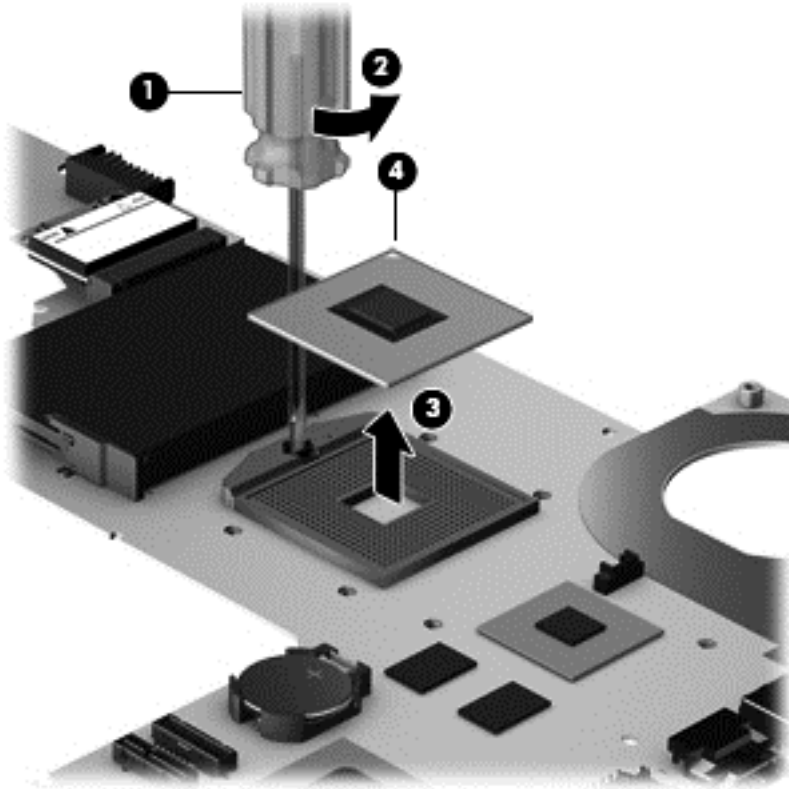

Reverse this procedure to install the processor.

5 Using Setup Utility (BIOS) and System Diagnostics in Windows 8

Setup Utility, or Basic Input/Output System (BIOS), controls communication between all the input and output devices on the system (such as disk drives, display, keyboard, mouse, and printer). Setup Utility (BIOS) includes settings for the types of devices installed, the startup sequence of the computer, and the amount of system and extended memory.

Starting Setup Utility (BIOS)

To start Setup Utility (BIOS), turn on or restart the computer, and then quickly press **F10**.

Information about how to navigate in Setup Utility (BIOS) is located at the bottom of the screen.

 **NOTE:** Use extreme care when making changes in Setup Utility (BIOS). Errors can prevent the computer from operating properly.

Updating the BIOS

Updated versions of the BIOS may be available on the HP website.

Most BIOS updates on the HP website are packaged in compressed files called *SoftPaqs*.

Some download packages contain a file named *Readme.txt*, which contains information regarding installing and troubleshooting the file.

Determining the BIOS version

To determine whether available BIOS updates contain later BIOS versions than those currently installed on the computer, you need to know the version of the system BIOS currently installed.

BIOS version information (also known as *ROM date* and *System BIOS*) can be displayed by pressing **Fn + Esc** (if you are already in Windows) or by using Setup Utility (BIOS).

1. Start Setup Utility (BIOS).
2. Use the arrow keys to select **Main**.
3. To exit Setup Utility (BIOS) without saving your changes, use the arrow keys to select **Exit > Exit Discarding Changes**, and then press **enter**.

Downloading a BIOS update

 **CAUTION:** To reduce the risk of damage to the computer or an unsuccessful installation, download and install a BIOS update only when the computer is connected to reliable external power using the AC adapter. Do not download or install a BIOS update while the computer is running on battery power, docked in an optional docking device, or connected to an optional power source. During the download and installation, follow these instructions:

Do not disconnect power from the computer by unplugging the power cord from the AC outlet.

Do not shut down the computer or initiate Sleep.

Do not insert, remove, connect, or disconnect any device, cable, or cord.

1. From the Start screen, select the **HP Support Assistant** app.
2. Select **Updates and tune-ups**, and then select **Check for HP updates now**.
3. Follow the on-screen instructions.
4. At the download area, follow these steps:
 - a. Identify the most recent BIOS update and compare it to the BIOS version currently installed on your computer. Make a note of the date, name, or other identifier. You may need this information to locate the update later, after it has been downloaded to your hard drive.
 - b. Follow the on-screen instructions to download your selection to the hard drive.

If the update is more recent than your BIOS, make a note of the path to the location on your hard drive where the BIOS update is downloaded. You will need to access this path when you are ready to install the update.

 **NOTE:** If you connect your computer to a network, consult the network administrator before installing any software updates, especially system BIOS updates.

BIOS installation procedures vary. Follow any instructions that are displayed on the screen after the download is complete. If no instructions are displayed, follow these steps:

1. From the Start screen, type `file`, and then select **File Explorer**.
2. Click your hard drive designation. The hard drive designation is typically Local Disk (C:).
3. Using the hard drive path you recorded earlier, open the folder on your hard drive that contains the update.
4. Double-click the file that has an `.exe` extension (for example, `filename.exe`).

The BIOS installation begins.

5. Complete the installation by following the on-screen instructions.

 **NOTE:** After a message on the screen reports a successful installation, you can delete the downloaded file from your hard drive.

Using System Diagnostics

System Diagnostics allows you to run diagnostic tests to determine if the computer hardware is functioning properly.

To start System Diagnostics:

1. Turn on or restart the computer, quickly press `esc`, and then press `f2`.
2. Click the diagnostic test you want to run, and then follow the on-screen instructions.



NOTE: If you need to stop a diagnostics test while it is running, press `esc`.

6 Using Setup Utility (BIOS) and System Diagnostics in Windows 7

Setup Utility, or Basic Input/Output System (BIOS), controls communication between all the input and output devices on the system (such as disk drives, display, keyboard, mouse, and printer). Setup Utility (BIOS) includes settings for the types of devices installed, the startup sequence of the computer, and the amount of system and extended memory.

Starting Setup Utility (BIOS)

To start Setup Utility (BIOS), follow these steps:

1. Turn on or restart the computer, and then press **esc** while the “Press the ESC key for Startup Menu” message is displayed at the bottom of the screen.
2. Press **f10** to enter Setup Utility (BIOS).

Information about how to navigate in Setup Utility (BIOS) is located at the bottom of the screen.

 **NOTE:** Use extreme care when making changes in Setup Utility (BIOS). Errors can prevent the computer from operating properly.

Updating the BIOS

Updated versions of the BIOS may be available on the HP website.

Most BIOS updates on the HP website are packaged in compressed files called *SoftPaqs*.

Some download packages contain a file named *Readme.txt*, which contains information regarding installing and troubleshooting the file.

Determining the BIOS version

To determine whether available BIOS updates contain later BIOS versions than those currently installed on the computer, you need to know the version of the system BIOS currently installed.

BIOS version information (also known as *ROM date* and *System BIOS*) can be displayed by pressing **fn** + **esc** (if you are already in Windows) or by using Setup Utility (BIOS).

1. Start Setup Utility (BIOS).
2. Use the arrow keys to select **Main**.
3. To exit Setup Utility (BIOS) without saving your changes, use the tab key and the arrow keys to select **Exit > Exit Discarding Changes**, and then press **enter**.

Downloading a BIOS update

 **CAUTION:** To reduce the risk of damage to the computer or an unsuccessful installation, download and install a BIOS update only when the computer is connected to reliable external power using the AC adapter. Do not download or install a BIOS update while the computer is running on battery power, docked in an optional docking device, or connected to an optional power source. During the download and installation, follow these instructions:

Do not disconnect power from the computer by unplugging the power cord from the AC outlet.

Do not shut down the computer or initiate Sleep or Hibernation.

Do not insert, remove, connect, or disconnect any device, cable, or cord.

1. Select **Start > Help and Support > Maintain**.
2. Follow the on-screen instructions to identify your computer and access the BIOS update you want to download.
3. At the download area, follow these steps:
 - a. Identify the BIOS update that is later than the BIOS version currently installed on your computer. Make a note of the date, name, or other identifier. You may need this information to locate the update later, after it has been downloaded to your hard drive.
 - b. Follow the on-screen instructions to download your selection to the hard drive.

Make a note of the path to the location on your hard drive where the BIOS update is downloaded. You will need to access this path when you are ready to install the update.

 **NOTE:** If you connect your computer to a network, consult the network administrator before installing any software updates, especially system BIOS updates.

BIOS installation procedures vary. Follow any instructions that are displayed on the screen after the download is complete. If no instructions are displayed, follow these steps:

1. Open Windows Explorer by selecting **Start > Computer**.
2. Double-click your hard drive designation. The hard drive designation is typically Local Disk (C:).
3. Using the hard drive path you recorded earlier, open the folder on your hard drive that contains the update.

4. Double-click the file that has an .exe extension (for example, *filename.exe*).

The BIOS installation begins.

5. Complete the installation by following the on-screen instructions.

 **NOTE:** After a message on the screen reports a successful installation, you can delete the downloaded file from your hard drive.

Using System Diagnostics

System Diagnostics allows you to run diagnostic tests to determine if the computer hardware is functioning properly.

To start System Diagnostics:

1. Turn on or restart the computer. While the “Press the ESC key for Startup Menu” message is displayed in the lower-left corner of the screen, press **esc**. When the Startup Menu is displayed, press **f2**.
2. Click the diagnostic test you want to run, and then follow the on-screen instructions.

 **NOTE:** If you need to stop a diagnostics test while it is running, press **esc**.

7 Specifications

Computer specifications

	Metric	U.S.
Dimensions		
Depth	23.1 cm	9.09 in
Width	34.2 cm	13.46 in
Height (front to back)	3.00 to 3.55 cm	1.18 to 1.40 in
Weight	2.19 kg	4.84 lb
Input power		
Operating voltage and current	18.5 V dc @ 3.5 A or 19.5 V dc @ 3.33 A – 65 W 19 V dc @ 4.74 A or 19.5 V dc @ 4.62 A – 90 W	
Temperature		
Operating	5°C to 35°C	41°F to 95°F
Nonoperating	-20°C to 60°C	-4°F to 140°F
Relative humidity (noncondensing)		
Operating	10% to 90%	
Nonoperating	5% to 95%	
Maximum altitude (unpressurized)		
Operating	-15 m to 3,048 m	-50 ft to 10,000 ft
Nonoperating	-15 m to 12,192 m	-50 ft to 40,000 ft
NOTE: Applicable product safety standards specify thermal limits for plastic surfaces. The device operates well within this range of temperatures.		

14.0-inch display specifications

	Metric	U.S.
Dimensions		
Height	17.6 cm	6.93 in
Width	31.2 cm	12.28 in
Diagonal	35.7 cm	14.06 in
Number of colors	Up to 16.8 million	
Contrast ratio	200:1 (typical)	
Brightness	200 nits (typical)	
Pixel resolution		
Pitch	0.197 × 0.197 mm	
Format	1366 × 768	
Configuration	RGB vertical stripe	
Backlight	LED	
Character display	80 × 25	
Total power consumption	2.0 W	
Viewing angle	±65° horizontal, ±50° vertical (typical)	

Hard drive specifications

	750-GB*	640-GB*	500-GB*	320-GB*
Dimensions				
Height	9.5 mm	9.5 mm	9.5 mm	9.5 mm
Length	100.4 mm	100.4 mm	100.4 mm	100.4 mm
Width	69.9 mm	69.9 mm	69.9 mm	69.9 mm
Weight	115.0 g	100.0 g	98.8 g	98.8 g
Interface type	SATA	SATA	SATA	SATA
Transfer rate				
Synchronous (maximum)	300 MB/sec	300 MB/sec	300 MB/sec	300 MB/sec
Security	ATA security	ATA security	ATA security	ATA security
Seek times (typical read, including setting)				
Single track	1.5 ms	1.5 ms	1.5 ms	1.5 ms
Average (read/write)	13 ms	13 ms	13 ms	13 ms
Maximum	27 ms	27 ms	27 ms	27 ms
Logical blocks	1,465,149,168	1,250,263,728	976,773,168	625,142,448
Disk rotational speed	5400 rpm	5400 rpm	5400 rpm	5400 rpm
Operating temperature	0°C to 60°C (32°F to 140°F)			
*1 GB = 1 billion bytes when referring to hard drive storage capacity. Actual accessible capacity is less.				
NOTE: Certain restrictions and exclusions apply. Contact technical support for details.				

8 Backing up, restoring, and recovering in Windows 8

Your computer includes tools provided by HP and the operating system to help you safeguard your information and retrieve it if you ever need to. These tools will help you return your computer to a proper working state or even back to the original factory state, all with simple steps.

This chapter provides information about the following processes:

- Creating recovery media and backups
- Restoring and recovering your system

 **NOTE:** This guide describes an overview of backing up, restoring and recovering options. For more details about the tools provided, see Help and Support. From the Start screen, type `help`, and then select **Help and Support**.

Creating recovery media and backups

Recovery after a system failure is only as good as your most recent backup.

1. After you successfully set up the computer, create HP Recovery media. This step creates a backup of the HP Recovery partition on the computer. The backup can be used to reinstall the original operating system in cases where the hard drive is corrupted or has been replaced.

HP Recovery media you create will provide the following recovery options:

- System Recovery—Reinstalls the original operating system and the programs that were installed at the factory.
- Minimized Image Recovery—Reinstalls the operating system and all hardware-related drivers and software, but not other software applications.
- Factory Reset—Restores the computer to the state its original factory state by deleting all information from the hard drive and re-creating the partitions. Then it reinstalls the operating system and the software that was installed at the factory.

See [Creating HP Recovery media on page 128](#).

2. As you add hardware and software programs, create system restore points. A system restore point is a snapshot of certain hard drive contents saved by Windows System Restore at a specific time. A system restore point contains information that Windows uses, such as registry settings. Windows creates a system restore point for you automatically during a Windows update and during other system maintenance (such as a software update, security scanning, or system diagnostics). You can also manually create a system restore point at any time. For more information and steps for creating specific system restore points, see Windows Help and Support. From the Start screen, type `help`, and then select **Help and Support**.
3. As you add photos, video, music, and other personal files, create a backup of your personal information. Windows File History can be set to regularly and automatically back up files from libraries, desktop, contacts, and favorites. If files are accidentally deleted from the hard drive and they can no longer be restored from the Recycle Bin, or if files become corrupted, you can restore the files that you backed up using File History. Restoring files is also useful if you ever choose to reset the computer by reinstalling Windows or choose to recover using HP Recovery Manager.

 **NOTE:** File History is not enabled by default, so you must turn it on.

For more information and steps for enabling Windows File History, see Windows Help and Support. From the Start screen, type `help`, and then select **Help and Support**.

Creating HP Recovery media

HP Recovery Manager is a software program that offers a way to create recovery media after you successfully set up the computer. HP Recovery media can be used to perform system recovery if the hard drive becomes corrupted. System recovery reinstalls the original operating system and the

software programs installed at the factory, and then configures the settings for the programs. HP Recovery media can also be used to customize the system or aid in the replacement of a hard drive.

- Only one set of HP Recovery media can be created. Handle these recovery tools carefully, and keep them in a safe place.
- HP Recovery Manager examines the computer and determines the required storage capacity for the blank USB flash drive or the number of blank DVD discs that will be required.
- To create recovery discs, your computer must have an optical drive with DVD writer capability, and you must use only high-quality blank DVD-R, DVD+R, DVD-R DL, DVD+R DL discs. Do not use rewritable discs such as CD±RW, DVD±RW, double-layer DVD±RW, or BD-RE (rewritable Blu-ray) discs; they are not compatible with HP Recovery Manager software. Or instead you can use a high-quality blank USB flash drive.
- Your computer does not include an integrated optical drive. You can use an optional external optical drive (purchased separately) to create recovery discs, or you can obtain recovery discs for your computer from the HP website. For U.S. support, go to <http://www.hp.com/go/contactHP>. For worldwide support, go to http://welcome.hp.com/country/us/en/wwcontact_us.html. If you use an external optical drive, it must be connected directly to a USB port on the computer; the drive cannot be connected to a USB port on an external device, such as a USB hub.
- Be sure that the computer is connected to AC power before you begin creating the recovery media.
- The creation process can take up to an hour or more. Do not interrupt the creation process.
- If necessary, you can exit the program before you have finished creating all of the recovery DVDs. HP Recovery Manager will finish burning the current DVD. The next time you start HP Recovery Manager, you will be prompted to continue, and the remaining discs will be burned.

To create HP Recovery media:

1. From the Start screen, type *recovery*, and then select **HP Recovery Manager**.
2. Select **Recovery Media Creation**, and follow the on-screen instructions to continue.

If you ever need to recover the system, see [Recovering using HP Recovery Manager on page 132](#).

Restore and recovery

There are several options for recovering your system. Choose the method that best matches your situation and level of expertise:

- If you need to restore your personal files and data, you can use Windows File History to restore your information from the backups you created. For more information and steps for using File History, see Windows Help and Support. From the Start screen, type `help`, and then select **Help and Support**.
- If you need to correct a problem with a preinstalled application or driver, use the Drivers and Applications Reinstall option of HP Recovery Manager to reinstall the individual application or driver.

From the Start screen, type `recovery`, select **HP Recovery Manager**, and then select **Drivers and Applications Reinstall**, and follow the on-screen instructions.

- If you want to restore the system to a previous state without losing any personal information, Windows System Restore is an option. System Restore allows you to restore without the requirements of Windows Refresh or a reinstallation. Windows creates system restore points automatically during a Windows update and other system maintenance events. Even if you did not manually create a restore point, you can choose to restore to a previous point, automatically created. For more information and steps for using Windows System Restore, see Windows Help and Support. From the Start screen, type `help`, and then select **Help and Support**.
- If you want a quick and easy way to recover the system without losing your personal information, settings, or apps that came preinstalled on your computer or were purchased from the Windows Store, consider using Windows Refresh. This option does not require backing up data to another drive. See [Using Windows Refresh for quick and easy recovery on page 131](#).
- If you want to reset your computer to its original state, Windows provides an easy way to remove all personal data, apps, and settings, and reinstall Windows.

For more information, see [Remove everything and reinstall Windows on page 131](#).

- If you want to reset your computer using a minimized image, you can choose the HP Minimized Image Recovery option from the HP Recovery partition (select models only) or HP Recovery media. Minimized Image Recovery installs only drivers and hardware-enabling applications. Other applications included in the image continue to be available for installation through the Drivers and Applications Reinstall option in HP Recovery Manager.

For more information, see [Recovering using HP Recovery Manager on page 132](#).

- If you want to recover the computer's original factory partitioning and content, you can choose the System Recovery option from the HP Recovery media. For more information, see [Recovering using HP Recovery Manager on page 132](#).
- If you have replaced the hard drive, you can use the Factory Reset option of HP Recovery media to restore the factory image to the replacement drive. For more information, see [Recovering using HP Recovery Manager on page 132](#).
- If you wish to remove the recovery partition to reclaim hard drive space, HP Recovery Manager offers the Remove Recovery Partition option.

For more information, see [Removing the HP Recovery partition on page 134](#).

Using Windows Refresh for quick and easy recovery

When your computer is not working properly and you need to regain system stability, the Windows Refresh option allows you to start fresh and keep what is important to you.

 **IMPORTANT:** Refresh removes any traditional applications that were not originally installed on the system at the factory.

 **NOTE:** During Refresh, a list of removed traditional applications will be saved so that you have a quick way to see what you might need to reinstall. See Help and Support for instructions on reinstalling traditional applications. From the Start screen, type `help`, and then select **Help and Support**.

 **NOTE:** You may be prompted for your permission or password when using Refresh. See Windows Help and Support for more information. From the Start screen, type `help`, and then select **Help and Support**.

To start Refresh:

1. From the Start screen, point to the upper-right or lower-right corner of the screen to display the charms.
2. When the charms list opens, click **Settings**.
3. Click **Change PC settings** in the bottom-right corner of the screen, and then select **General** from the PC settings screen.
4. Under **Refresh your PC without affecting your files**, select **Get started**, and follow the on-screen instructions.

Remove everything and reinstall Windows

Sometimes you want to perform detailed reformatting of your computer, or you want to remove personal information before you give away or recycle your computer. The process described in this section provides a speedy, simple way to return the computer to its original state. This option removes all personal data, apps, and settings from your computer, and reinstalls Windows.

 **IMPORTANT:** This option does not provide backups of your information. Before using this option, back up any personal information you wish to retain.

You can initiate this option by using the `f11` key or from the Start screen.

To use the `f11` key:

1. Press `f11` while the computer boots.
– or –
Press and hold `f11` as you press the power button.
2. Select **Troubleshoot** from the boot options menu.
3. Select **Reset your PC**, and follow the on-screen instructions.

To use the Start screen:

1. From the Start screen, point to the upper-right or lower-right corner of the screen to display the charms.
2. When the charms list opens, click **Settings**.
3. Click **Change PC settings** in the bottom-right corner of the screen, and then select **General** from the PC settings screen.
4. Under **Remove everything and reinstall Windows**, select **Get started**, and follow the on-screen instructions.

Recovering using HP Recovery Manager

HP Recovery Manager software allows you to recover the computer to its original factory state. Using the HP Recovery media you created, you can choose from one of the following recovery options:

- System Recovery—Reinstalls the original operating system, and then configures the settings for the programs that were installed at the factory.
- Minimized Image Recovery—Reinstalls the operating system and all hardware-related drivers and software, but not other software applications.
- Factory Reset—Restores the computer to the state its original factory state by deleting all information from the hard drive and re-creating the partitions. Then it reinstalls the operating system and the software that was installed at the factory.

The HP Recovery partition (select models only) allows Minimized Image Recovery.

What you need to know

- HP Recovery Manager recovers only software that was installed at the factory. For software not provided with this computer, you must either download the software from the manufacturer's website or reinstall the software from the media provided by the manufacturer.
- Recovery through HP Recovery Manager should be used as a final attempt to correct computer issues.
- HP Recovery media must be used if the computer hard drive fails.
- To use the Factory Reset or System Recovery options, you must use HP Recovery media.
- If the HP Recovery media do not work, you can obtain recovery media for your system from the HP website. For U.S. support, go to <http://www.hp.com/go/contactHP>. For worldwide support, go to http://welcome.hp.com/country/us/en/wwcontact_us.html.



IMPORTANT: HP Recovery Manager does not automatically provide backups of your personal data. Before beginning recovery, back up any personal data you wish to retain.

Using the HP Recovery partition to recover a minimized image (select models only)

The HP Recovery partition (select models only) allows you to perform a minimized image recovery without the need for recovery discs or a recovery USB flash drive. This type of recovery can only be used if the hard drive is still working.

To start HP Recovery Manager from the HP Recovery partition:

1. Press **f11** while the computer boots.
– or –
Press and hold **f11** as you press the power button.
2. Select **Troubleshoot** from the boot options menu.
3. Select **HP Recovery Manager**, and follow the on-screen instructions.

Using HP Recovery media to recover

You can use HP Recovery media to recover the original system. This method can be used if your system does not have an HP Recovery partition or if the hard drive is not working properly.

1. If possible, back up all personal files.
2. Insert the first HP Recovery disc you created into an optional external optical drive, and then restart the computer.

– or –

Insert the HP Recovery USB flash drive you created into a USB port on your computer, and then restart the computer.

 **NOTE:** If the computer does not automatically restart in HP Recovery Manager, change the computer boot order. See [Changing the computer boot order on page 133](#).

3. Follow the on-screen instructions.

Changing the computer boot order

If computer does not restart in HP Recovery Manager, you can change the computer boot order, which is the order of devices listed in BIOS where the computer looks for startup information. You can change the selection for an optional external optical drive or a USB flash drive.

To change the boot order:

1. Insert the HP Recovery media you created.
2. Restart the computer.
3. Press and hold **esc** while the computer is restarting, and then press **f9** for boot options.

4. Select the optical drive or USB flash drive you want to boot from.
5. Follow the on-screen instructions.

Removing the HP Recovery partition

HP Recovery Manager software allows you to remove the HP Recovery partition to free up hard drive space.



IMPORTANT: Removing the HP Recovery partition means you can no longer use Windows Refresh, the Windows Remove everything and reinstall Windows option, or the HP Recovery Manager option for minimized image recovery. Create HP Recovery media before removing the Recovery partition to ensure you have recovery options; see [Creating HP Recovery media on page 128](#).

Follow these steps to remove the HP Recovery partition:

1. From the Start screen, type `recovery`, and then select **HP Recovery Manager**.
2. Select **Remove Recovery Partition**, and follow the on-screen instructions to continue.

9 Backing up, restoring, and recovering in Windows 7

Your computer includes tools provided by the operating system and HP to help you safeguard your information and retrieve it if ever needed.

Creating backups

1. Use HP Recovery Manager to create recovery media immediately after you set up the working computer.
2. As you add hardware and software programs, create system restore points.
3. As you add photos, video, music, and other personal files, create a backup of your system and personal information.

Creating recovery media to recover the original system

After you successfully set up the computer, you should create recovery discs or a recovery flash drive using HP Recovery Manager. You will need these recovery discs or recovery flash drive to perform a system recovery should the hard drive become corrupted. A system recovery reinstalls the original operating system, and then configures the settings for the default programs.

What you need to know

- Only one set of recovery media can be created. Handle these recovery tools carefully, and keep them in a safe place.
- HP Recovery Manager examines the computer and determines the required storage capacity for the flash drive or the number of blank DVD discs that will be required.

Use DVD-R, DVD+R, DVD-R DL, DVD+R DL discs or a flash drive. Do not use rewriteable discs such as CD±RW, DVD±RW, double-layer DVD±RW, and BD-RE (rewritable Blu-ray) discs; they are not compatible with HP Recovery Manager software.

- Your computer does not include an integrated optical drive. You can use an optional external optical drive (purchased separately) to create recovery discs, or you can obtain recovery discs for your computer from the HP website. If you use an external optical drive, it must be connected directly to a USB port on the computer, not to a USB port on an external device, such as a USB hub.

- Be sure that the computer is connected to AC power before you begin creating the recovery media.
- The creation process can take up to an hour or more. Do not interrupt the creation process.
- Store the recovery media in a safe location, separate from the computer.
- If necessary, you can exit the program before you have finished creating the recovery media. The next time you open HP Recovery Manager, you will be prompted to continue the process.

Creating the recovery media

1. Select **Start** and type `recovery` in the search field. Select **Recovery Manager** from the list. Allow the action to continue, if prompted.
2. Click **Recovery Media Creation**.
3. Follow the on-screen instructions to continue.

To recover, see [Recovering the original system using HP Recovery Manager on page 139](#).

Creating system restore points

A system restore point is a snapshot of certain hard drive contents saved by Windows System Restore at a specific time. A restore point contains information such as registry settings that Windows uses. Restoring to a previous restore point allows you to reverse changes that have been made to the system since the restore point was created.

Restoring to an earlier system restore point does not affect data files saved or emails created since the last restore point, but it does affect software you may have installed.

For example, if you download a photo from a digital camera and then restore the computer to the state it was on the previous day, the photo remains on the computer.

However, if you install photo viewing software and then restore your computer to the state it was on the previous day, the software will be uninstalled, and you won't be able to use it.

What you need to know

- If you restore to a restore point and then change your mind, you can undo the restoration.
- You should create system restore points:
 - Before you add or change software or hardware
 - Periodically, whenever the computer is running normally
- System Restore also saves shadow copies of files that have been changed since the last restore point was created. For more information about using shadow copies to restore, see Help and Support.

Creating a system restore point

1. Select **Start > Control Panel > System and Security > System**.
2. In the left pane, click **System Protection**.
3. Click the **System Protection** tab.
4. Click **Create**, and follow the on-screen instructions.

To restore, see [Restoring to a previous system restore point on page 139](#).

Backing up system and personal information

Your computer stores information that is important to you, such as files, emails, and photos, and you will want to keep that information even if you download a virus or the system stops working properly. How completely you are able to recover your files depends on how recent your backup is. As you add new software and data files, you should create backups on a regular basis.

Tips for a successful backup

- Number backup discs before inserting them into the optical drive.
- Store personal files in the Documents, Music, Pictures, and Videos libraries, and back up these folders periodically.
- Save customized settings in a window, toolbar, or menu bar by taking a screen shot of your settings. The screen shot can be a time-saver if you have to re-enter your preferences.

To create a screen shot:

1. Display the screen you want to save.
2. Copy the screen image:
To copy only the active window, press **alt+prt sc**.
To copy the entire screen, press **prt sc**.
3. Open a word-processing document or graphics editing program, and then select **Edit > Paste**. The screen image is added to the document.
4. Save and print the document.

What you need to know

- You can back up your information to an optional external hard drive, a flash drive, a network drive, or discs.
- Connect the computer to AC power during backups.
- Allow enough time for the backup. Depending on files sizes, it may take more than an hour.

- Verify the amount of free space on your backup storage device before you back up.
- You should back up:
 - Before adding or changing software or hardware.
 - Before the computer is repaired or restored.
 - On a regular schedule to be sure you have recent copies of personal information.
 - After you add many files—for example, if you saved videos from a birthday party.
 - Before using antivirus software to remove a malicious program.
 - After adding information that is hard to replace, such as pictures, videos, music, project files, or data records.

Creating a backup using Windows Backup and Restore

Windows allows you to back up files using Windows Backup and Restore. You can select the level you want to back up, from individual folders to drives. The backups are compressed to save space. To back up:

1. Select **Start > Control Panel > System and Security > Backup and Restore**.
2. Follow the on-screen instructions to schedule and create a backup.



NOTE: Windows includes the User Account Control feature to improve the security of the computer. You may be prompted for your permission or password for tasks such as installing software, running utilities, or changing Windows settings. See Help and Support for more information.

To restore, see [Restoring specific files using Windows Backup and Restore on page 139](#).

Restore and recovery

Restoring to a previous system restore point

Sometimes installing a software program causes your computer or Windows to behave unpredictably. Usually uninstalling the software fixes the problems. If uninstalling does not fix the problems, you can restore the computer to a previous system restore point (created at an earlier date and time).

To restore to a previous system restore point, when the computer was running correctly:

1. Select **Start > Control Panel > System and Security > System**.
2. In the left pane, click **System Protection**.
3. Click the **System Protection** tab.
4. Click **System Restore**, and follow the on-screen instructions.

Restoring specific files

If files are accidentally deleted from the hard disk and they can no longer be restored from the Recycle Bin, or if files become corrupt, restoring specific files is useful. Restoring specific files is also useful if you ever choose to recover the original system using HP Recovery Manager. You can only restore specific files that you have backed up before.

Restoring specific files using Windows Backup and Restore

Windows allows you to restore files that were backed up using Windows Backup and Restore:

1. Select **Start > Control Panel > System and Security > Backup and Restore**.
2. Follow the on-screen instructions to restore your backup.



NOTE: Windows includes the User Account Control feature to improve the security of the computer. You may be prompted for your permission or password for tasks such as installing software, running utilities, or changing Windows settings. See Help and Support for more information.

Recovering the original system using HP Recovery Manager

HP Recovery Manager software allows you to repair or recover the computer to its original factory state.

What you need to know

- HP Recovery Manager recovers only software that was installed at the factory. For software not provided with this computer, you must either download the software from the manufacturer's website or reinstall the software from the disc provided by the manufacturer.
- A system recovery should be used as a final attempt to correct computer issues. If you have not already tried restore points (see [Restoring to a previous system restore point on page 139](#)) and partial restores (see [Restoring specific files on page 139](#)), try them before using HP Recovery Manager to recover your system.
- A system recovery must be performed if the computer hard drive fails or if all attempts to correct any functional computer issues fail.
- If the recovery media do not work, you can obtain recovery discs for your system from the HP website.
- The Minimized Image Recovery option is recommended for advanced users only. All hardware-related drivers and software are re-installed, but other software applications are not. Do not interrupt the process until it is complete, otherwise the recovery will fail.

Recovering using HP Recovery partition (select models only)

The HP Recovery partition (select models only), allows you to restore your system without the need for recovery discs or a recovery flash drive. This type of recovery can only be used if the hard drive is still working.

To check for the presence of a recovery partition, select **Start**, right-click **Computer** then select **Manage > Disk Management**. If the recovery partition is present, a Recovery drive is listed in the window.



NOTE: Recovery discs have been included if your computer did not ship with a recovery partition.

1. Access HP Recovery Manager in either of the following ways:
 - Select **Start** and type `recovery` in the search field. Select **Recovery Manager** from the list.
 - or –
 - Turn on or restart the computer, and then press `esc` while the “Press the ESC key for Startup Menu” message is displayed at the bottom of the screen. Then press `f11` while the “F11 (System Recovery)” message is displayed on the screen.
2. Click **System Recovery** in the **HP Recovery Manager** window.
3. Follow the on-screen instructions.

Recovering using the recovery media

1. If possible, back up all personal files.
2. Insert the first recovery disc into the optional external optical drive, and then restart the computer.

– or –

Insert the recovery flash drive into a USB port on your computer, and then restart the computer.



NOTE: If the computer does not automatically restart in HP Recovery Manager, change the computer boot order. See [Changing the computer boot order on page 141](#).

3. Press **f9** at system bootup.
4. Select the optical drive or the flash drive.
5. Follow the on-screen instructions.

Changing the computer boot order

To change the boot order for recovery discs:

1. Restart the computer.
2. Press **esc** while the computer is restarting, and then press **f9** for boot options.
3. Select the optical drive from the boot options window.

To change the boot order for a recovery flash drive:

1. Insert the flash drive into a USB port.
2. Restart the computer.
3. Press **esc** while the computer is restarting, and then press **f9** for boot options.
4. Select the flash drive from the boot options window.

10 Power cord set requirements

The wide-range input feature of the computer permits it to operate from any line voltage from 100 to 120 volts ac, or from 220 to 240 volts ac.

The 3-conductor power cord set included with the computer meets the requirements for use in the country or region where the equipment is purchased.

Power cord sets for use in other countries and regions must meet the requirements of the country or region where the computer is used.

Requirements for all countries

The following requirements are applicable to all countries and regions:

- The length of the power cord set must be at least **1.0 m** (3.3 ft) and no more than **2.0 m** (6.5 ft).
- All power cord sets must be approved by an acceptable accredited agency responsible for evaluation in the country or region where the power cord set will be used.
- The power cord sets must have a minimum current capacity of 10 A and a nominal voltage rating of 125 or 250 V ac, as required by the power system of each country or region.
- The appliance coupler must meet the mechanical configuration of an EN 60 320/IEC 320 Standard Sheet C13 connector for mating with the appliance inlet on the back of the computer.

Requirements for specific countries and regions

Country/region	Accredited agency	Applicable note number
Argentina	IRAM	1
Australia	SAA	1
Austria	OVE	1
Belgium	CEBEC	1
Brazil	ABNT	1
Canada	CSA	2
Chile	IMQ	1
Denmark	DEMKO	1
Finland	FIMKO	1
France	UTE	1
Germany	VDE	1
India	ISI	1
Israel	SII	1
Italy	IMQ	1
Japan	JIS	3
The Netherlands	KEMA	1
New Zealand	SANZ	1
Norway	NEMKO	1
The People's Republic of China	CCC	4
Saudi Arabia	SASO	7
Singapore	PSB	1
South Africa	SABS	1
South Korea	KTL	5
Sweden	SEMKO	1
Switzerland	SEV	1
Taiwan	BSMI	6
Thailand	TISI	1
The United Kingdom	ASTA	1

Country/region	Accredited agency	Applicable note number
The United States	UL	2
<ol style="list-style-type: none"> 1. The flexible cord must be Type HO5VV-F, 3-conductor, 0.75mm² conductor size. Power cord set fittings (appliance coupler and wall plug) must bear the certification mark of the agency responsible for evaluation in the country or region where it will be used. 2. The flexible cord must be Type SVT/SJT or equivalent, No. 18 AWG, 3-conductor. The wall plug must be a two-pole grounding type with a NEMA 5-15P (15 A, 125 V ac) or NEMA 6-15P (15 A, 250 V ac) configuration. CSA or C-UL mark. UL file number must be on each element. 3. The appliance coupler, flexible cord, and wall plug must bear a “T” mark and registration number in accordance with the Japanese Dentori Law. The flexible cord must be Type VCTF, 3-conductor, 0.75mm² or 1.25mm² conductor size. The wall plug must be a two-pole grounding type with a Japanese Industrial Standard C8303 (7 A, 125 V ac) configuration. 4. The flexible cord must be Type RVV, 3-conductor, 0.75mm² conductor size. Power cord set fittings (appliance coupler and wall plug) must bear the CCC certification mark. 5. The flexible cord must be Type H05VV-F 3X0.75mm² conductor size. KTL logo and individual approval number must be on each element. Corset approval number and logo must be printed on a flag label. 6. The flexible cord must be Type HVCTF 3X1.25mm² conductor size. Power cord set fittings (appliance coupler, cable, and wall plug) must bear the BSMI certification mark. 7. For 127 V ac, the flexible cord must be Type SVT or SJT 3 x 18 AWG, with plug NEMA 5-15P (15 A, 125 V ac), with UL and CSA or C-UL marks. For 240 V ac, the flexible cord must be Type H05VV-F 3X0.75/1.00mm² conductor size, with plug BS 1363/A with BSI or ASTA marks. 		

11 Recycling

Battery

When a non-rechargeable or rechargeable battery has reached the end of its useful life, do not dispose of the battery in general household waste. Follow the local laws and regulations in your area for battery disposal.

HP encourages customers to recycle used electronic hardware, HP original print cartridges, and rechargeable batteries. For more information about recycling programs, see the HP Web site at <http://www.hp.com/recycle>.

Display

⚠ WARNING! The backlight contains mercury. Caution must be exercised when removing and handling the backlight to avoid damaging this component and causing exposure to the mercury.

⚠ CAUTION: The procedures in this chapter can result in damage to display components. The only components intended for recycling purposes are the liquid crystal display (LCD) panel and the backlight. When you remove these components, handle them carefully.

📄 NOTE: Materials Disposal. This HP product contains mercury in the backlight in the display assembly that might require special handling at end-of-life. Disposal of mercury may be regulated because of environmental considerations. For disposal or recycling information, contact your local authorities, or see the Electronic Industries Alliance (EIA) Web site at <http://www.eiai.org>.

This section provides disassembly instructions for the display assembly. The display assembly must be disassembled to gain access to the backlight **(1)** and the liquid crystal display (LCD) panel **(2)**.

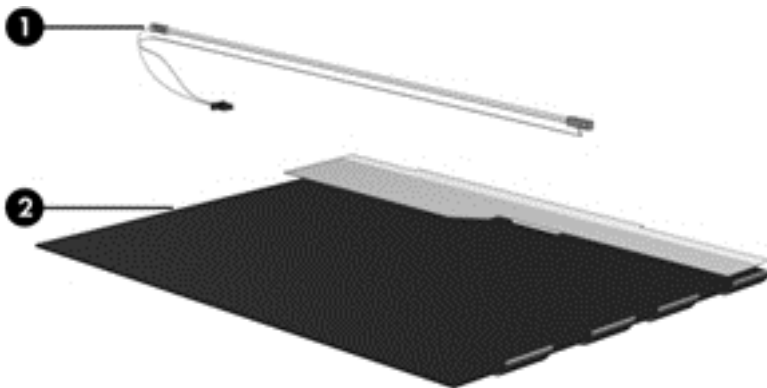

 **NOTE:** The procedures provided in this chapter are general disassembly instructions. Specific details, such as screw sizes, quantities, and locations, and component shapes and sizes, can vary from one computer model to another.

Perform the following steps:

1. Remove all screw covers **(1)** and screws **(2)** that secure the display bezel to the display assembly.

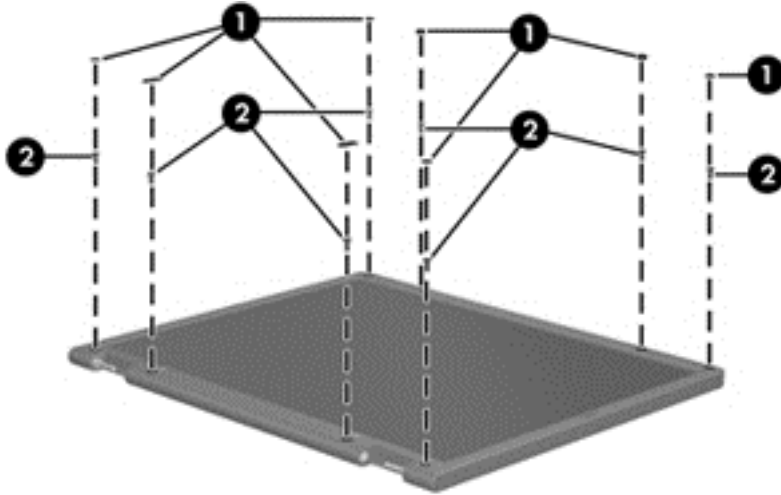

2. Lift up and out on the left and right inside edges **(1)** and the top and bottom inside edges **(2)** of the display bezel until the bezel disengages from the display assembly.
3. Remove the display bezel **(3)**.

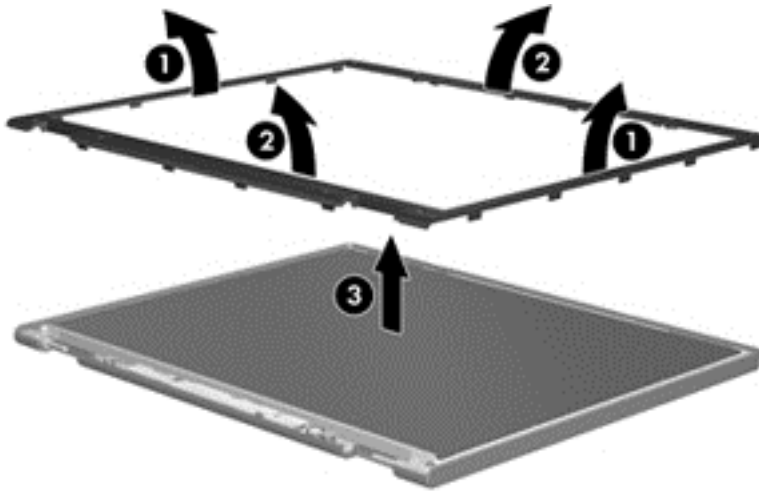

4. Disconnect all display panel cables **(1)** from the display inverter and remove the inverter **(2)**.

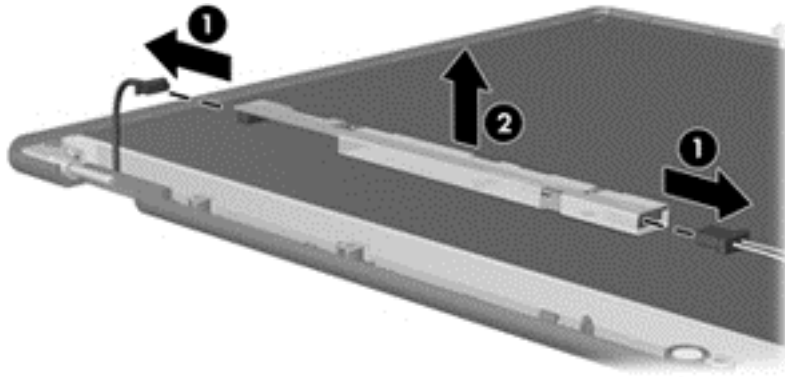

5. Remove all screws **(1)** that secure the display panel assembly to the display enclosure.
6. Remove the display panel assembly **(2)** from the display enclosure.

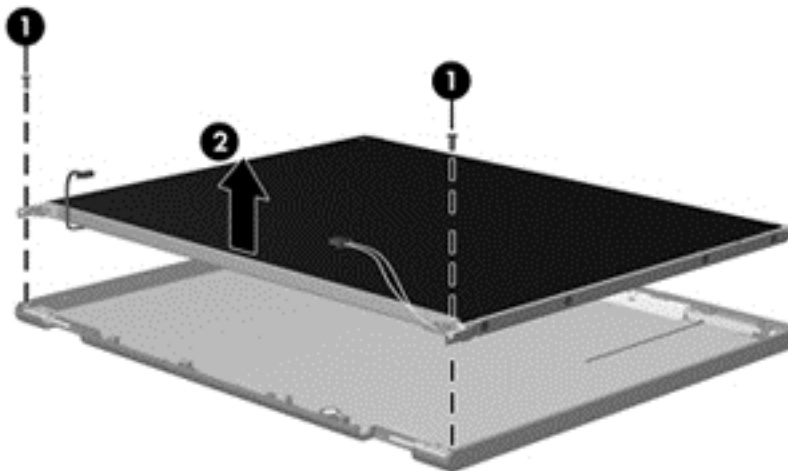

7. Turn the display panel assembly upside down.
8. Remove all screws that secure the display panel frame to the display panel.

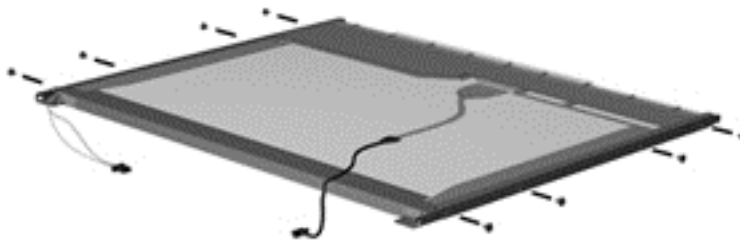

9. Use a sharp-edged tool to cut the tape **(1)** that secures the sides of the display panel to the display panel frame.

10. Remove the display panel frame **(2)** from the display panel.

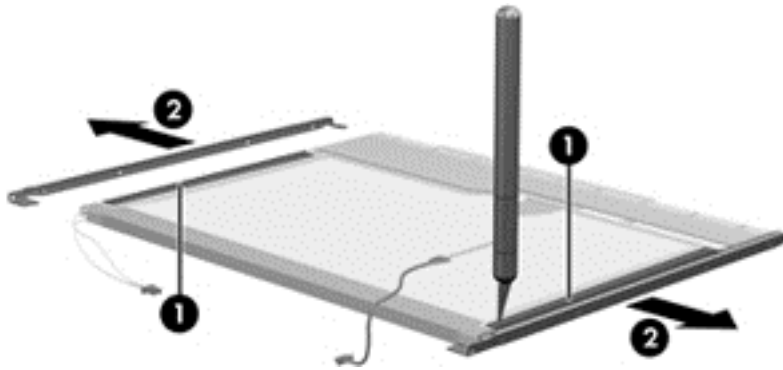

11. Remove the screws **(1)** that secure the backlight cover to the display panel.

12. Lift the top edge of the backlight cover **(2)** and swing it outward.

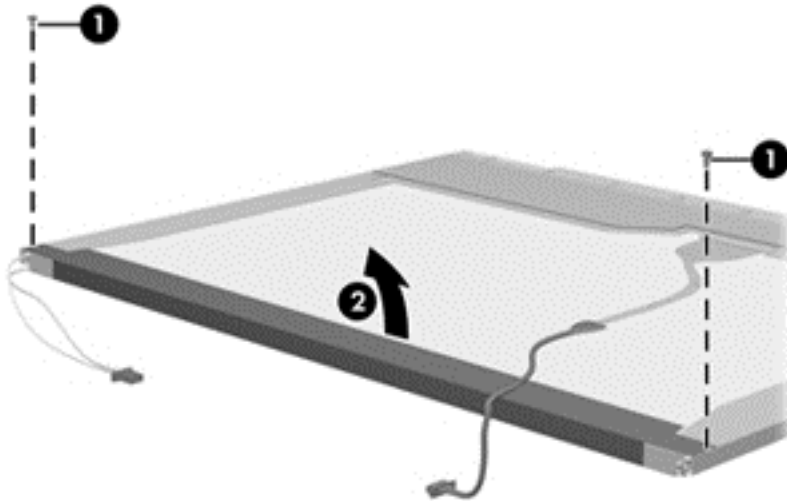

13. Remove the backlight cover.

14. Turn the display panel right-side up.

15. Remove the backlight cables (1) from the clip (2) in the display panel.

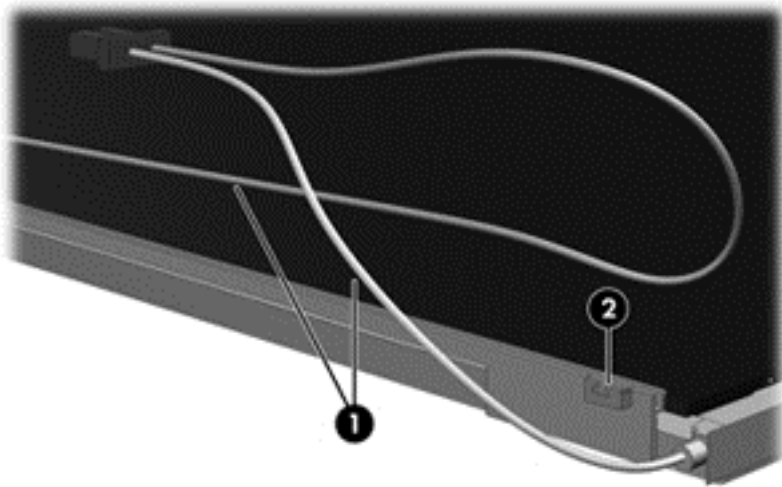

16. Turn the display panel upside down.
17. Remove the backlight frame from the display panel.

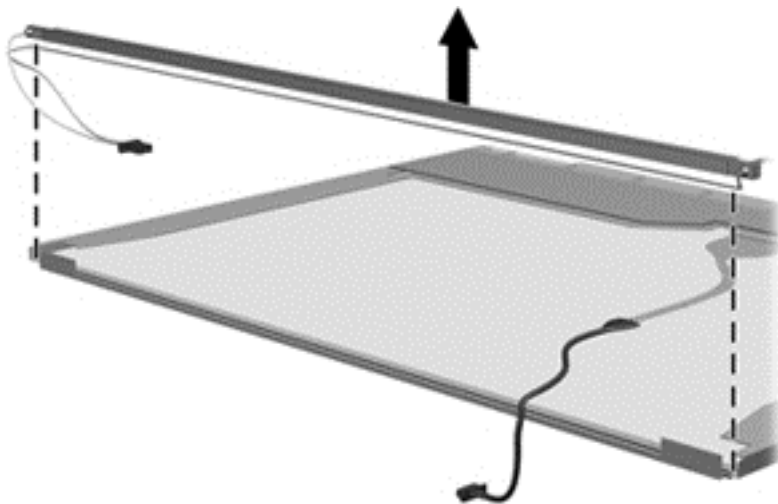

⚠ WARNING! The backlight contains mercury. Exercise caution when removing and handling the backlight to avoid damaging this component and causing exposure to the mercury.

18. Remove the backlight from the backlight frame.

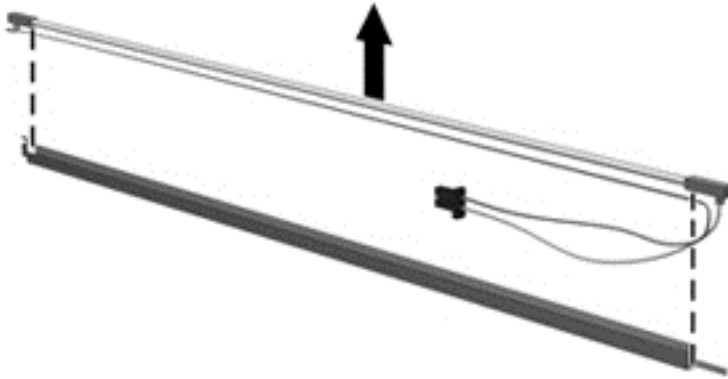

19. Disconnect the display cable **(1)** from the LCD panel.

20. Remove the screws **(2)** that secure the LCD panel to the display rear panel.

21. Release the LCD panel **(3)** from the display rear panel.

22. Release the tape **(4)** that secures the LCD panel to the display rear panel.

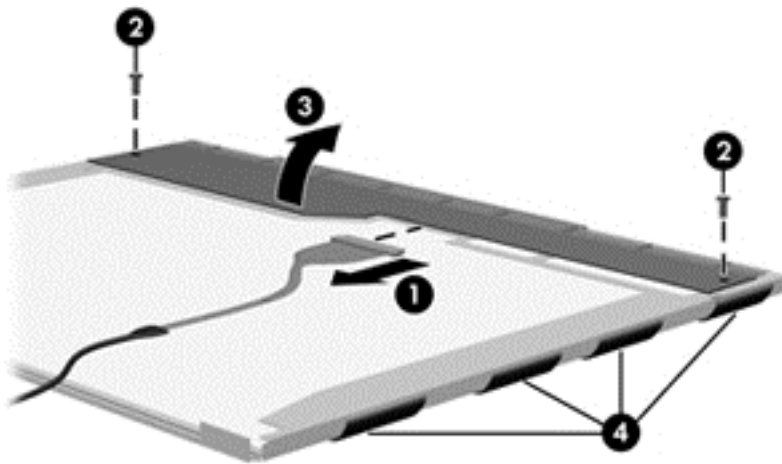

23. Remove the LCD panel.

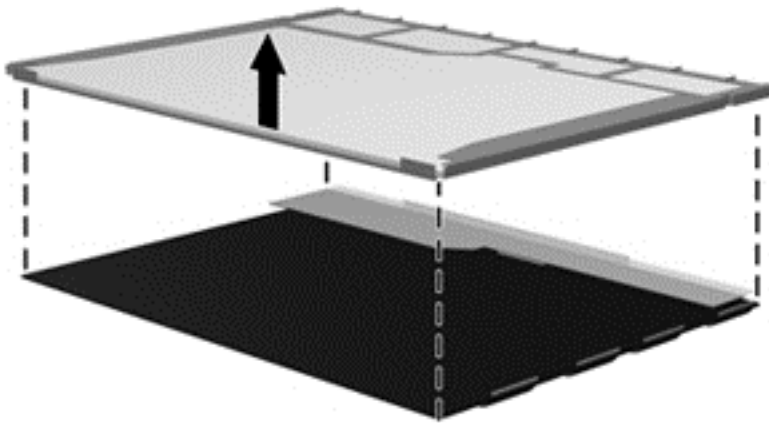

24. Recycle the LCD panel and backlight.

Index

A

- AC adapter 20
- AC adapter, spare part number 44, 45
- action keys
 - identifying 26
- antennas
 - illustrated 37
 - removing 101
 - spare part number 42
- audio, product description 4, 13
- audio-in (microphone) jack 21
- audio-out (headphone) jack 21

B

- back up
 - personal files 128
- backups 127, 135
- base enclosure
 - illustrated 35
 - spare part number 45
- battery
 - illustrated 35
 - removing 56
 - spare part number 41
- battery bay 27, 29
- battery release latch 27
- BIOS
 - determining version 118, 121
 - downloading an update 119, 122
 - updating 118, 121
- Bluetooth label 29
- boot order
 - changing 141
 - changing HP Recovery Manager 133
- buttons
 - left 23

- on/off 23
- power 25
- right 23

C

- cables, service considerations 48
- caps lock light, identifying 24
- chipset, product description 2, 10
- components
 - bottom 27
 - display 19
 - front 20
 - left side 21
 - right side 20
 - top 23
- computer feet
 - locating 55
 - spare part number 43
- computer major components, illustrated 30
- computer reset 131
- computer specifications 124
- connector, power 20
- connectors, service considerations 48

D

- deleted files
 - restoring 130, 139
- display assembly
 - illustrated 31
 - removing 57, 93
- display assembly subcomponents
 - illustrated 36
 - removing 57, 93
- display bezel
 - illustrated 36
 - removing 57, 95
 - spare part number 42, 47

- display bumpers, spare part number 43
- display cable
 - illustrated 37
 - removing 99
 - spare part number 42, 47
- display enclosure
 - illustrated 37, 46
 - removing 101
- display panel
 - illustrated 37
 - product description 2, 11
 - removing 62, 99
 - spare part number 43, 45
- display specifications 125

E

- electrostatic discharge 49
- equipment guidelines 52
- esc key, identifying 26
- Ethernet, product description 4, 14
- external media cards 5, 15
- external monitor port 21

F

- fan/heat sink assembly
 - illustrated 31
 - removing 109
 - spare part number 42, 44
- feet
 - locating 55
 - spare part number 43
- fn key, identifying 26

G

- graphics, product description 2, 10
- grounding guidelines 49

- guidelines
 - equipment 52
 - grounding 49
 - packaging 51
 - transporting 51
 - workstation 51
- H**
- hard drive
 - illustrated 35, 38
 - precautions 49
 - product description 3, 12
 - removing 70
 - spare part number 41, 42
 - specifications 126
- hard drive bay, identifying 28
- hard drive bracket
 - illustrated 39
 - removing 71
 - spare part number 42
- hard drive cable
 - illustrated 39
 - removing 71
 - spare part number 42
- hard drive compartment cover
 - illustrated 39
 - removing 71
 - spare part number 43
- Hard Drive Hardware Kit
 - illustrated 31, 39
 - spare part number 42
- hard drive light 22
- HDMI port, identifying 21
- hinge covers
 - illustrated 37
 - removing 98
 - spare part number 42
- hinges
 - illustrated 37
 - removing 99
 - spare part number 42
- HP Recovery Manager 132, 139
 - correcting boot problems 133
 - starting 133
- HP Recovery media
 - creating 128
 - recovery 133
- HP Recovery partition 133
 - recovery 133
 - removing 134

- I**
- integrated webcam light, identifying 19
- internal display switch, identifying 19
- internal microphone, identifying 19

- J**
- jacks
 - audio-in (microphone) 21
 - audio-out (headphone) 21
 - network 21
 - RJ-45 (network) 21

- K**
- keyboard
 - illustrated 31
 - product description 6, 15
 - removing 76
 - spare part number 45
- keys
 - action 26
 - esc 26
 - fn 26
 - Windows applications 26
 - Windows logo 26

- L**
- labels
 - Bluetooth 29
 - regulatory 29
 - serial number 29
 - service 29
 - wireless certification 29
 - WLAN 29
- latch, battery release 27
- light 23
- lights 23
 - AC adapter 20
 - caps lock 24
 - hard drive 22
 - power 22, 24
 - webcam 19
 - wireless 24

- M**
- mass storage devices
 - illustrated 38
 - precautions 49

- Media card reader, identifying 21
- memory module
 - illustrated 35
 - product description 2, 11
 - removing 67
 - spare part number 41
- memory module compartment, identifying 28
- memory module/wireless module compartment cover
 - illustrated 39
 - removing 65
 - spare part number 43
- microphone
 - product description 4, 13
- minimized image
 - creating 132
- minimized image recovery 133
- model name 1, 8
- Mylar screw covers, spare part number 42, 47

- N**
- network jack, identifying 21

- O**
- operating system 6, 16
- optical drive
 - illustrated 35, 39
 - precautions 49
 - product description 3, 13
 - removing 74
 - spare part number 42
- optical drive cable
 - illustrated 31, 39
 - removing 107
 - spare part number 42
- optical drive cable bracket
 - removing 107
 - spare part number 42
- optical drive rear bracket
 - removing 75
 - spare part number 42
- original system recovery 132, 139

- P**
- packaging guidelines 51
- PCID label 54

- plastic parts, service considerations 48
 - Plastics Kit
 - illustrated 31, 39
 - spare part number 43
 - pointing device 6, 15
 - ports
 - external monitor 21
 - HDMI 21
 - product description 5, 15
 - USB 20, 21
 - power button board
 - illustrated 31
 - removing 83
 - spare part number 42
 - power button, identifying 25
 - power connector cable
 - illustrated 33
 - removing 91
 - spare part number 42
 - power connector, identifying 20
 - power cord
 - requirements for all countries 142
 - requirements for specific countries and regions 143
 - set requirements 142
 - spare part number 41
 - power lights, identifying 22, 24
 - power requirements 6, 16
 - processor
 - illustrated 34
 - product description 1, 8
 - removing 115
 - spare part number 41, 42, 44
 - product description
 - audio 4, 13
 - chipset 2, 10
 - display panel 2, 11
 - Ethernet 4, 14
 - external media cards 5, 15
 - graphics 2, 10
 - hard drive 3, 12
 - keyboard 6, 15
 - memory module 2, 11
 - microphone 4, 13
 - operating system 6, 16
 - optical drive 3, 13
 - pointing device 6, 15
 - ports 5, 15
 - power requirements 6, 16
 - processor 1, 8
 - product name 1, 8
 - security 6, 16
 - serviceability 7, 18
 - video 4, 13
 - wireless 4, 14
 - product name 1, 8
 - product name and number, computer 29
- R**
- recovering from the recovery discs 141
 - recovering the original system 139
 - recovery 130, 131, 139
 - discs 129, 133
 - HP Recovery Manager 132, 139
 - media 133
 - starting 133
 - supported discs 129
 - system 132
 - USB flash drive 133
 - using HP Recovery media 129
 - recovery discs 135
 - recovery media 135
 - creating 128
 - creating using HP Recovery Manager 129
 - recovery partition 133
 - removing 134
 - recovery, system 139
 - recycle
 - computer 130, 131
 - refresh 131
 - computer 130
 - regulatory information
 - regulatory label 29
 - wireless certification labels 29
 - removal/replacement
 - preliminaries 48
 - procedures 53
 - remove everything and reinstall Windows 131
 - reset
 - computer 130, 131
 - steps 131
 - restore
 - Windows File History 130
 - restore points 136
 - restoring the original system
 - creating recovery media 135
 - RJ-45 (network) jack, identifying 21
 - RTC battery
 - illustrated 34
 - removing 73
 - spare part number 41
 - rubber
 - computer feet, spare part number 43
 - display bumpers, spare part number 43
- S**
- Screw Kit, spare part number 43
 - security cable slot, identifying 20
 - security, product description 6, 16
 - serial number 29
 - serial number, computer 29
 - service considerations
 - cables 48
 - connectors 48
 - plastic parts 48
 - service labels
 - locating 29
 - service tag 53
 - serviceability, product description 7, 18
 - slots
 - Media card reader 21
 - security cable 20
 - speakers
 - illustrated 31
 - removing 87
 - spare part number 43
 - speakers, identifying 20
 - specifications
 - computer 124
 - display 125
 - hard drive 126
 - supported discs 135
 - recovery 129
 - system board
 - illustrated 31

- removing 102
- spare part number 43, 44, 45
- system recovery 132, 139
- system restore point
 - creating 128
 - restoring 130
- system restore points 136
 - creating 136

T

- thermal pad, spare part number 41
- tools required 48
- top cover
 - illustrated 31
 - removing 79
- TouchPad button board
 - illustrated 31
 - removing 85
 - spare part number 43
- transporting guidelines 51
- traveling with the computer 29

U

- USB board
 - illustrated 31
 - removing 89
 - spare part number 42
- USB ports, identifying 20, 21

V

- vents, identifying 21, 27
- video, product description 4, 13

W

- webcam light, identifying 19
- webcam, identifying 19
- webcam/microphone cable
 - illustrated 37
 - removing 99
 - spare part number 42, 47
- webcam/microphone module
 - illustrated 36
 - removing 59, 96
 - spare part number 43, 45
- Windows
 - backup 128
 - File History 128, 130
 - Refresh 130, 131
 - reinstall 130, 131

- remove everything and reinstall
 - option 131
 - reset 131
 - restoring files 130
 - system restore point 128, 130
- Windows applications key, identifying 26
- Windows Backup and Restore
 - restoring files 139
- Windows logo key, identifying 26
- wireless antennas
 - illustrated 37
 - removing 101
 - spare part number 42
- wireless certification label 29
- wireless light 24
- wireless module compartment, identifying 28
- wireless, product description 4, 14
- WLAN antenna, identifying 19
- WLAN device 29
- WLAN label 29
- WLAN module
 - illustrated 34
 - removing 64
 - spare part number 41, 42
- workstation guidelines 51

Z

- zone, identifying 23