



# Impressora Matricial Diebold Star DP8340

A impressora matricial Diebold DP8340 SM tem com aplicações típicas a impressão de: notas fiscais, comprovantes de entrega, relatórios de dados, equipamentos de medição e outros.

[www.bztech.com.br](http://www.bztech.com.br)

Dot Matrix Printer  
**DP8340 SERIES**

[SERIAL INTERFACE]

*USERS MANUAL*



**Federal Communications Commission  
Radio Frequency Interference  
Statement**

This equipment has been tested and found to comply with the limits for a Class A digital device, pursuant to Part 15 of the FCC Rules. These limits are designed to provide reasonable protection against harmful interference when the equipment is operated in a commercial environment. This equipment generates, uses and can radiate radio frequency energy and, if not installed and used in accordance with the instruction manual, may cause harmful interference to radio communications. Operation of this equipment in a residential area is likely to cause harmful interference in which case the user will be required to correct the interference at his own expense.

For compliance with the Federal Noise Interference Standard, this equipment requires a shielded cable.

*This statement will be applied only for the printers marketed in U.S.A.*

**Statement of  
The Canadian Department of Communications  
Radio Interference Regulations**

This Class A digital apparatus complies with Canadian ICES-003.

Cet appareil numérique de la classe A est conforme à la norme NMB-003 du Canada.

*The above statement applies only to printers marketed in Canada.*

***Trademark acknowledgments***

DP8340: *Star Micronics Co. Ltd.*

***Notice***

- All rights reserved. Reproduction of any part of this manual in any form whatsoever, without STAR's express permission is forbidden.
- The contents of this manual are subject to change without notice.
- All efforts have been made to ensure the accuracy of the contents of this manual at the time of going to press. However, should any errors be detected, STAR would greatly appreciate being informed of them.
- The above notwithstanding, STAR can assume no responsibility for any errors in this manual.

# TABLE OF CONTENTS

<b>1. OUTLINE</b> .....	<b>1</b>
<b>2. UNPACKING AND INSTALLATION</b> .....	<b>2</b>
2-1. Unpacking.....	2
2-2. Installation of Paper Holders and Re-Roll Prevention Guard (Only Model DP8340F) .....	3
2-3. Handling Care .....	4
2-4. Maintenance .....	5
<b>3. PART IDENTIFICATION AND NOMENCLATURE</b> .....	<b>6</b>
3-1. Power Supply Unit .....	6
3-2. Printer .....	7
3-3. Part Functional Description.....	8
<b>4. INSTALLATION OF INK RIBBON AND PAPER</b> .....	<b>9</b>
4-1. Installation of Ink Ribbon.....	9
4-2. Removal of Ink Ribbon .....	10
4-3. Paper Insertion.....	11
4-3-1. Model DP8340F .....	11
4-3-2. Model DP8340S .....	12
4-4. Paper Removal .....	13
<b>5. CONTROL CODES</b> .....	<b>14</b>
<b>6. GENERAL SPECIFICATIONS</b> .....	<b>15</b>
<b>7. INTERFACE FOR MODEL DP8340-M (MODULAR JACK CONNECTOR)</b> .....	<b>19</b>
7-1. Interface Specifications .....	19
7-2. Interface Circuit .....	19
7-3. Setting of the DIP Switches .....	20
7-3-1. DIP-SW 1.....	20
7-3-2. DIP-SW2.....	20
7-4. Connectors and Signals.....	21
7-5. Interface Connections.....	22
7-6. Peripheral Unit Drive Circuit.....	23
7-6-1. Cable Connection .....	24
7-6-2. Peripheral Drive Circuit .....	25
7-6-3. Control Codes.....	25

<b>8. INTERFACE FOR MODEL DP8340-D</b>	
<b>(D-SUB 25 PIN CONNECTOR)</b> .....	<b>26</b>
8-1. Interface Specifications .....	26
8-2. Interface Circuit .....	27
8-2-1. RS-232C .....	27
8-2-2. Current Loop.....	27
8-3. Setting of the DIP Switches .....	28
8-3-1. DIP-SW 1.....	28
8-3-2. DIP-SW 2.....	28
8-4. Jumper Setting.....	29
8-4-1. Removal of the Bottom Cover .....	29
8-4-2. Setting of Jumper .....	29
8-5. Connectors and Signals.....	30
8-6. Interface Connections .....	31
8-7. Peripheral Unit Drive Circuit.....	32
8-7-1. Cable Connection .....	33
8-7-2. Peripheral Drive Circuit .....	34
8-7-3. Control Codes .....	34
<b>9. DATA STRUCTURE AND CONTROL</b> .....	<b>35</b>
9-1. DTR Mode (1 BLOCK).....	35
9-2. X-ON/X-OFF Mode.....	36
9-3. STX-ETX Mode .....	38
<b>10. CHARACTER CODE LIST</b> .....	<b>40</b>
<b>11. FONT LIST</b> .....	<b>43</b>
<b>12. WHEN POWER IS SUPPLIED BY THE USER</b> .....	<b>47</b>
<b>13. FERRITE CORE INSTALLATION (EU ONLY)</b> .....	<b>48</b>

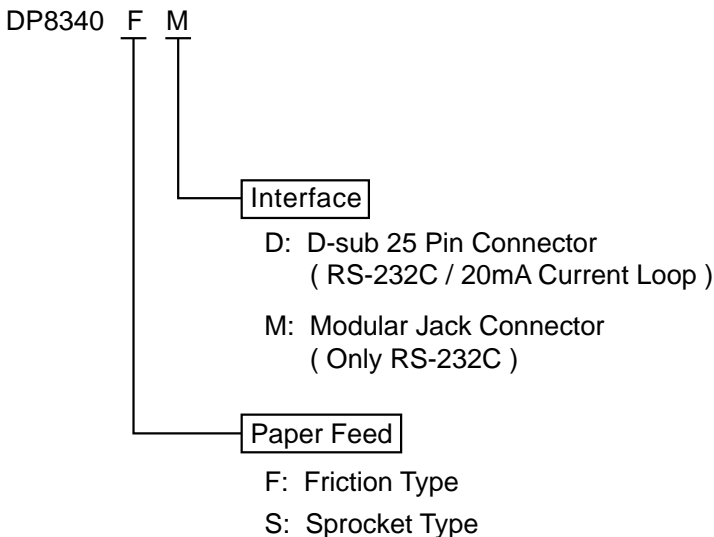
# 1. OUTLINE

The DP8340 series of serial dot matrix printers is for use in ECR, POS, electronic instruments, banking machines and computer peripheral equipment.

The DP8340 series include the following features;

- 1) 2 color printing (Red and Black)
- 2) High-speed bidirectional printing (2 line/sec, 40 columns per line)
- 3) 9-pin print head
- 4) The interface conforms to RS-232C in M type, and to RS-232C/20mA Current Loop in D type.
- 5) Commands for expanded characters, inverted characters, emphasized characters, and red and black printing are provided, which makes the printer very versatile.
- 6) Simultaneous Data Communication and Printing
- 7) Error Checking Protocol
- 8) Peripheral Driver
- 9) Reverse Channel providing status and full control

## Model Name Notation

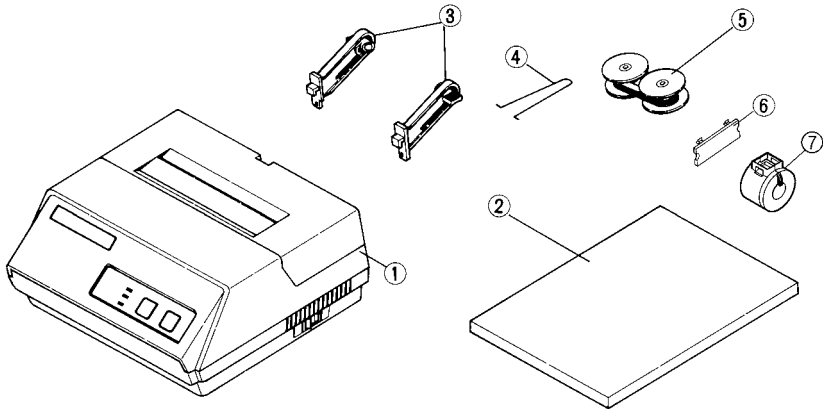


## 2. UNPACKING AND INSTALLATION

### 2-1. Unpacking

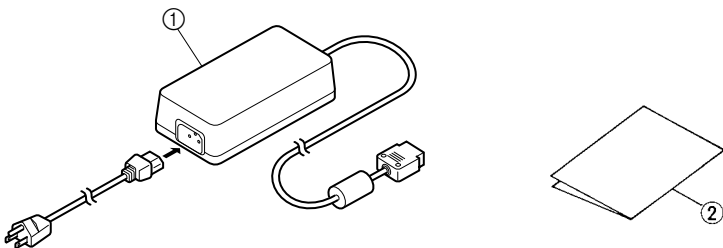
After opening the box, check if all necessary accessories are included.

#### (A) Printer



- ① Printer
- ② User's Manual
- ③ Paper Holders
- ④ Re-Roll Prevention Guard
- ⑤ Ink Ribbon
- ⑥ DIP Switch Cover
- ⑦ Ferrite Core (EU only)

#### (B) Power Supply Unit (Option: PS8340A)



- ① Power Supply Unit
- ② User's Manual

Figure 2-1. Unpacking

## 2-2. Installation of Paper Holders and Re-Roll Prevention Guard (Only Model DP8340F)

Install the Paper Holders in the outermost holes in the rear of the printer.

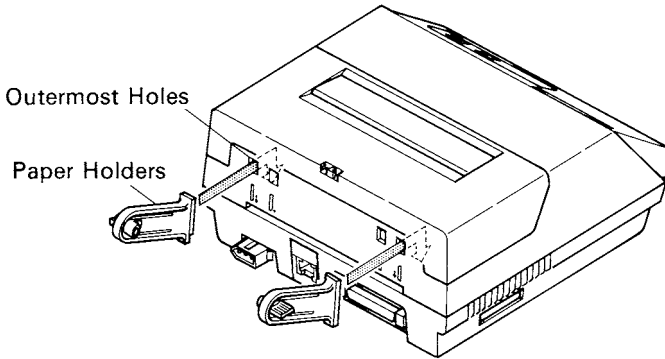


Figure 2-2. Installation of Paper Holders

Install the Re-Roll Prevention Wire in the holes of the printer cover. Twisting the Wire as shown in the figure below, will make the installation easier.

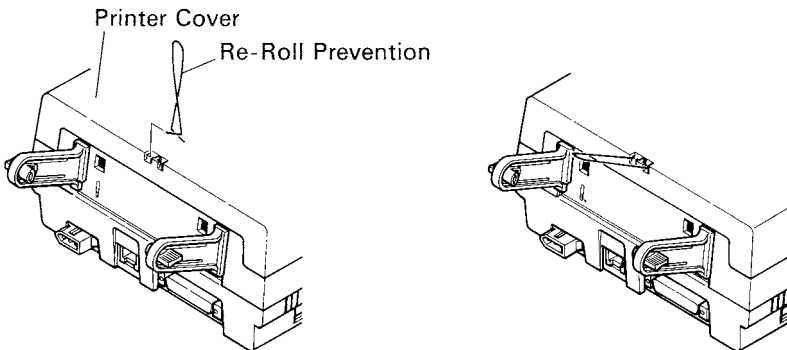


Figure 2-3. Installation of Re-Roll Prevention



## 2-3. Handling Care

1. Be careful not to drop paper clips, pins or other foreign matter into the unit as these cause the printer to malfunction.
2. Do not attempt to print when either paper or ribbon cartridge is not located in the printer, otherwise the print head can be damaged.
3. Do not open the cover while printing.
4. Do not touch the print head immediately after printing as it gets very hot.
5. Use only roll paper that is not glued to the core.
6. When the paper end mark appears on the paper, replace the roll paper before it runs out.

### WARNING

- ✓ Shut down your equipment immediately if it produces smoke, a strange odor, or unusual noise. Immediately unplug the equipment and contact your dealer for advice.
- ✓ Never attempt to repair this product yourself. Improper repair work can be dangerous.
- ✓ Never disassemble or modify this product. Tampering with this product may result in injury, fire, or electric shock.
- ✓ During and immediately after printing, the area around the print head is very hot. Do not touch it, as you could be burned.

### CAUTION

- ✓ We recommend that you unplug the printer from the power outlet whenever you do not plan to use it for long periods. Because of this, you should locate the printer so that the power outlet it is plugged into is nearby and easy to access.
- ✓ If the voltage shown on the label on the of your printer does not match the voltage for your area, contact your dealer immediately.
- ✓ Make sure that the printer is turned off and unplugged from the AC outlet and that the computer is turned off before making connections.
- ✓ Do not connect a telephone line into the modular connector.
- ✓ Do not pull out paper while the printer cover is closed.
- ✓ If liquids, foreign objects (coins and paper clips), and so on enter the printer, turn off the printer, unplug it from the AC outlet, and contact your dealer for advice. Continued use could cause a short circuit, which may result in fire or electric shock.

## **2-4. Maintenance**

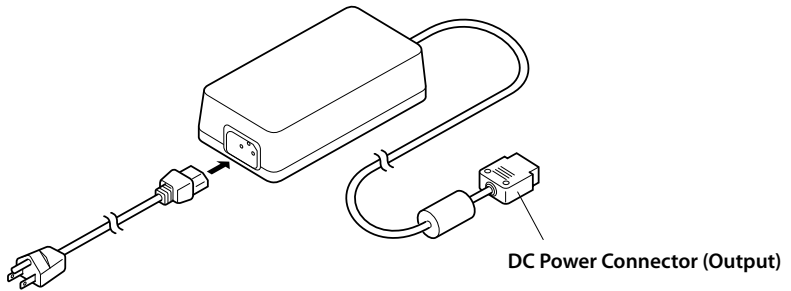
Essentially, your printer is a robust piece of equipment, but should be treated with a modicum of care in order to avoid malfunctions. For example:

1. Keep your printer in a “comfortable” environment. Roughly speaking, if you feel comfortable, then the environment is suitable for your printer.
2. Do not subject the printer to physical shocks or excessive vibration.
3. Avoid over-dusty environments. Dust is the enemy of all precision mechanical devices.
4. To clean the exterior of the printer, use a cloth barely dampened with either water with a little detergent or a little alcohol, but do not allow any liquid to fall inside the printer.
5. The interior of the printer may be cleaned with a small cleaner or a compressed-air aerosol (sold for this purpose). When performing this operation, be sure not to bend or damage any cable connections or electronic components.

# 3. PART IDENTIFICATION AND NOMENCLATURE

## 3-1. Power Supply Unit (Option)

Model name : PS8340A  
Input : 100 to 240V AC, 50/60 Hz  
Output : DC12V±5% 2.0A



Shape of AC Power plug will vary according to destinations.

**Figure 3-1. Power Supply Unit**

## 3-2. Printer

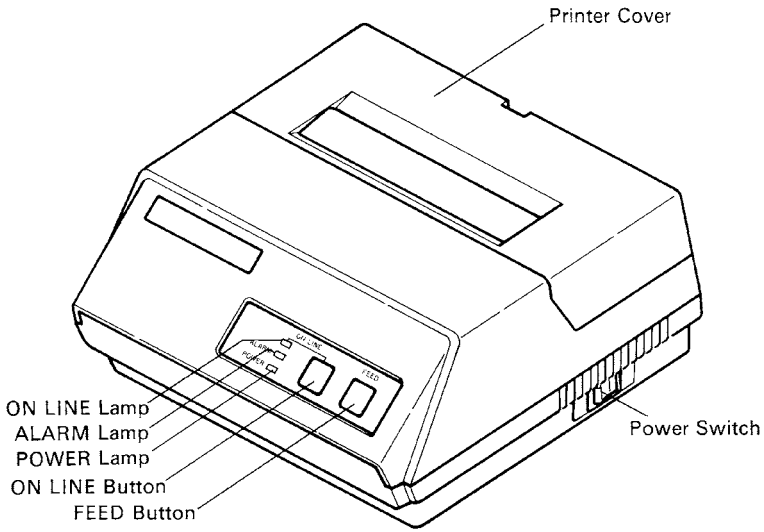


Figure 3-2. Printer: Front View

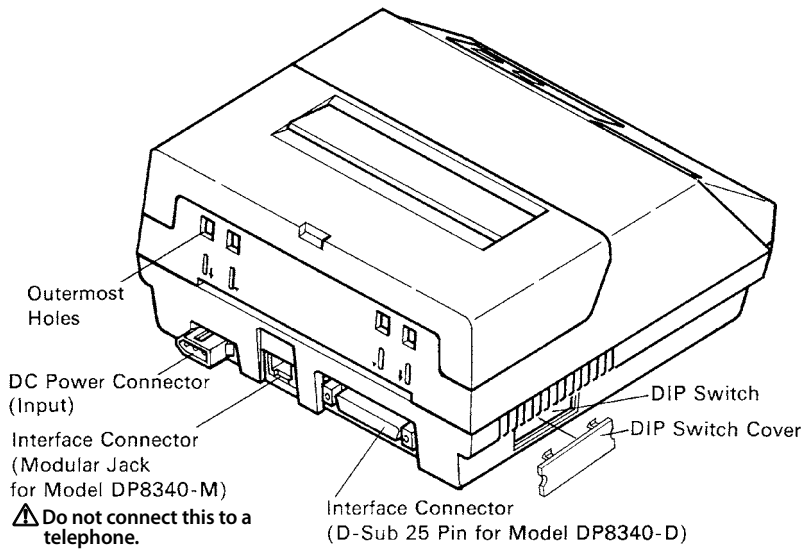


Figure 3-3. Printer: Rear View

### 3-3. Part Functional Description

- (1) AC Power Plug : Connect to an outlet of the specified voltage.
- (2) DC Power Outlet : Supplies DC 12V power to the printer.
- (3) Printer Cover : Protects the printer against dust and reduces noise.
- (4) POWER Lamp : Lights up (green LED) when power is on.
- (5) ON LINE Lamp : Lights up (green LED) when the unit is in the online mode.
- (6) ALARM Lamp : Lights up (red LED) when printer operation is not normal, or the printer is out of paper. It is necessary to install paper into the printer and press the ON LINE Button to recover from paper empty status. Turn off the printer power in order to recover from abnormal operation.
- (7) ON LINE Button : Toggles between the on-line and off-line modes. The printer will go on-line after turning power on.
- (8) FEED Button : Momentary operation of this button provides one line feed. Pressing this button continuously will cause continuous paper feed. If power is turned on while pressing this button, self printing\*1 will be performed.
- (9) Interface Connector : Connects the printer to host computers. Check that both computer and printer are off before connecting.
- (10) DIP Switches : Allows for setting of various functions according to user requirements.

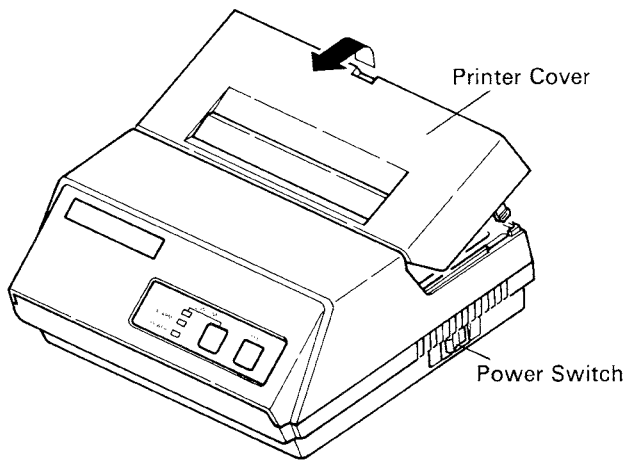
\*1 Self Printing                      This printer has another convenient function, the Automatic Test Printing. With the ink ribbon and paper properly installed in the printer, turn the power ON while holding down the Feed switch. Test printing will start and stop again automatically.

## 4. INSTALLATION OF INK RIBBON AND PAPER

### 4-1. Installation of Ink Ribbon

- (1) Turn power off, lift the Printer Cover up and remove it.

**Note:** Be careful not to touch the print head immediately after printing, because it can get very hot.

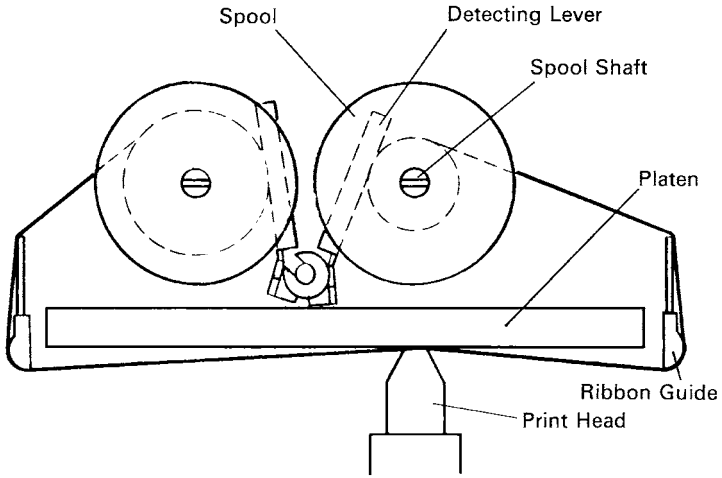


**Figure 4-1. Printer Cover Removal**

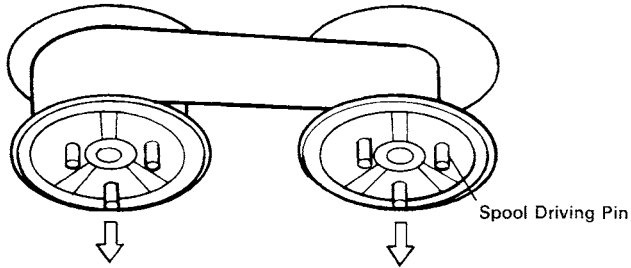
- (2) Unwind ribbon so that the spools are separated as shown in Figure 4-3. Hold the ribbon taut as shown with the drive pins facing down and slide the ribbon between the print head and the platen. While keeping the ribbon taut, wrap one side around the black ribbon guide on the end of the platen and drop one spool on the spool shaft. As you move the spool downwards, move the detecting lever aside to allow the spool to drop into place. Make sure the spool drive pins engage with the spool drive holes. As the spool drops into place there will be a click.
- (3) While continuing to hold the ribbon taut, install the remaining ribbon spool in a similar fashion.
- (4) Turn the spool that rotates freely to take up the ribbon slack.

#### Ribbon Life

Description	Ribbon life	
	Black	Red
SF-03BR	Approx. 0.8 million characters	Approx. 0.4 million characters



**Figure 4-2. Installation of Ink Ribbon**



**Figure 4-3. Ribbon Spools**

## 4-2. Removal of Ink Ribbon

Hold the spool and lift gently, rotating it until the ribbon sags. Push the ribbon detecting lever out, lift the spool until it comes off the shaft. Remove the second spool in a similar manner.

(Do not apply excessive force when lifting spools.)

## 4-3. Paper Insertion

### 4-3-1. Model DP8340F

- (1) Cut the Roll Paper end straight and square. Hold the roll so that the paper comes from the bottom.
- (2) Attach the Roll Paper to the Holders Paper by slipping one side of the roll onto the Hub and pulling the other Hub out to allow the roll to slip in place.
- (3) Insert the paper evenly into the Paper Insertion Slot.
- (4) Turn the Power Switch "ON", and press the FEED Button. The paper will be fed into the unit.

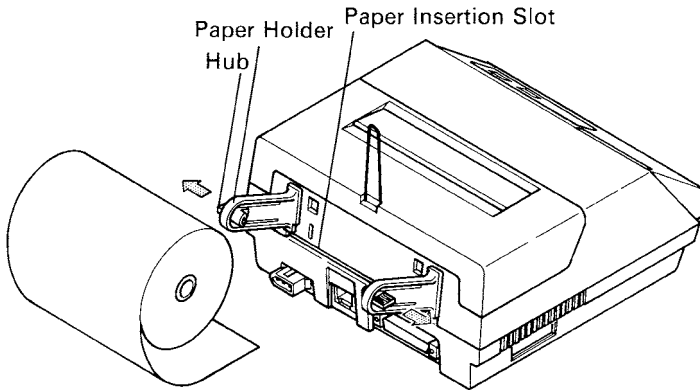


Figure 4-4. Paper Insertion (1) [Model DP8340F]

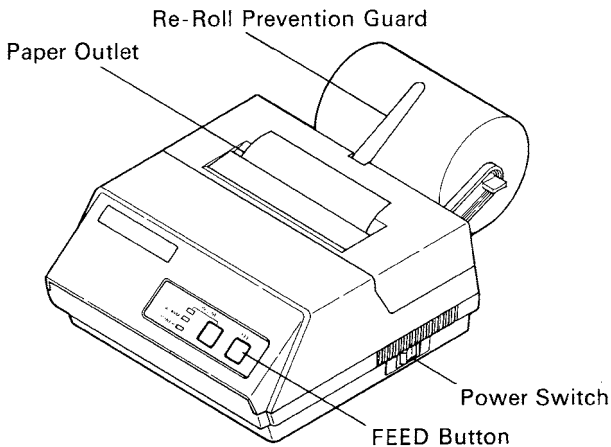


Figure 4-5. Paper Insertion (2) [Model DP8340F]



### 4-3-2. Model DP8340S

1. Make a straight cut along the top of the paper, about 1/4 inch away from the sprocket holes, (as shown in the figure). If there is perforation, cut the paper on the perforation.
2. Insert the paper squarely into the paper insertion slot until the ALARM lamp goes out. Then, hold down the FEED switch to advance the paper 8 lines, and release the switch when 8-line feeding is completed.  
If the paper is not fed straight during 8-line feeding, straighten the paper by pulling it back slowly as you hold the paper release lever down. If a sprocket hole is torn or enlarged, recut the paper and reinsert it as before.
3. After confirming that the paper has been fed in straight, feed the paper continuously by holding the feed switch down.
4. Release the feed switch when the paper emerges through the paper outlet.

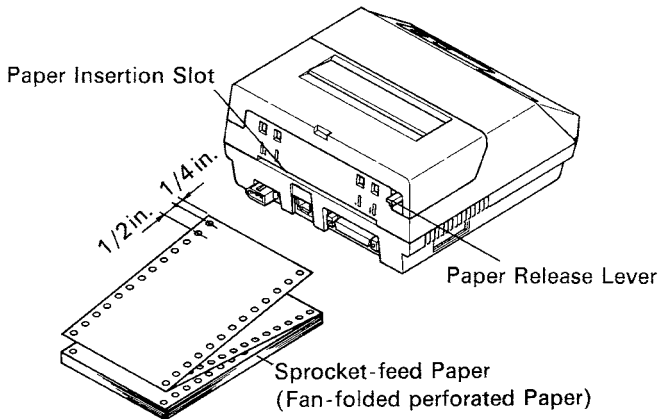


Figure 4-6. Paper Insertion (1) [Model DP8340S]

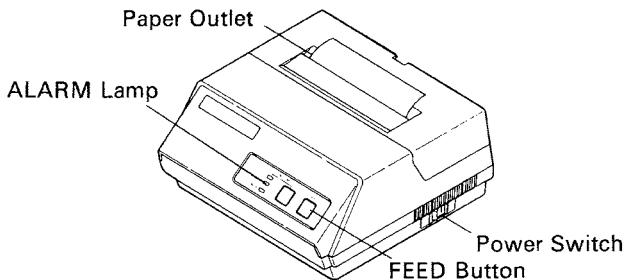


Figure 4-7. Paper Insertion (2) [Model DP8340S]

#### **4-4. Paper Removal**

Cut the paper close to the slot and use the feed button until paper has passed completely through the printer.

**Note: Do not try to remove the paper by hand as it could become crooked and get jammed inside the printer.**

# 5. CONTROL CODES

## Character Code List

Character		Code	Function
1	LF	(0A)H	Print and line feed instruction
2	CR	(0D)H	Print and line feed instruction (same as LF)
3	SO	(0E)H	Expanded character instruction
4	DC4	(14)H	Expanded character release
5	ESC-1	(1B)H (2D)H(01)H (1B)H (2D)H (31)H	Underline instruction
6	ESC-0	(1B)H (2D)H(00)H (1B)H (2D)H (30)H	Underline release
7	SI	(0F)H	Inverted print instruction
8	DC2	(12)H	Inverted print release
9	ESC E	(1B)H (45)H	Emphasized print instruction (one-way printing)
10	ESC F	(1B)H (46)H	Emphasized print release
11	ESC 4	(1B)H (34)H	Red character print instruction
12	ESC 5	(1B)H (35)H	Red character print release
13	ESC a n	(1B)H (61)H n	n-line feed instruction
14	ESC C n	(1B)H (43)H n	Sets page length in lines $1 \leq n \leq 120$ (default $n = 42$ )
15	ESC N n	(1B)H (4E)H n	Set bottom margin in lines $0 \leq n \leq 120$ (default $n = 0$ )
16	ESC O	(1B)H (4F)H	Cancel Bottom margin
17	FF	(0C)H	Form feed
18	ESC @	(1B)H (40)H	Printer initialization instruction
19	ESC BEL n1 n2	(1B)H (07)H n1 n2	Set peripheral unit drive pulse duration $1 \leq n1 \leq 127, 1 \leq n2 \leq 127$ (default $n1 = n2 = 20$ )
20	BEL	(07)H	Trigger peripheral unit drive (Deferred)
21	FS	(1C)H	Trigger peripheral unit drive (Immediate)
22	ENQ	(05)H	Enquiry
23	STX	(02)H	Start of text enter STX-ETX mode
24	ETX	(03)H	End of text end STX-ETX mode
25	CAN	(18)H	Clears print buffer

## 6. GENERAL SPECIFICATIONS

Printing method :	Serial impact dot matrix printing, 9 wires
Number of print columns :	40 columns, 12 CPI
Print speed :	Approx. 2 lines/sec
Print direction :	Bi-directional
Line spacing :	1/6 inch
Paper feed method :	Friction Feed or Sprocket-feed
Paper feed speed :	Approx. 12 lines/sec
Character set :	ASCII 96 characters
	International and symbol 64 characters
	Block graphics* 64 characters
Font configuration :	Ordinary characters 5 × 9 dots
	Block graphics* 6 × 6 dots
	* Graphic Feed Not Available
Character size :	2.42 (H) × 1.71(W) mm
Dot spacing :	0.35 (H) × 0.35 (W) mm
Print area :	84.3 mm
Print Buffer :	Approx. 1.5 KB
Serial Interface :	
Model DP8340-M	Only RS-232C
Model DP8340-D	RS-232C/20mA Current Loop
External dimensions :	
(Printer)	202(W) × 200(D) × 98(H) mm (without paper holder, DC Power Connector)
(Power supply unit)	54(W) × 114(D) × 36(H) mm (without AC cable)
Weight :	
(Printer)	Approx. 1.9 kg
(Power supply unit)	Approx. 0.3 kg (without AC cable)
Power supply unit :	

Four supplies available with following ratings

Input	Output
AC 100 to 240 V 50/60 Hz 0.6 A	DC 12.0 V ± 5%  2.0 A

Paper specification :		
Paper type	Ordinary and carbonless copy paper	
Size Paper width	114.3 mm (4.5 inches)	
Roll diameter	80 mm outer diameter (Max)	
Thickness (single)	0.07 mm (52.3 g/m <sup>2</sup> ) to 0.09 mm (64g/m <sup>2</sup> )	
(2 copy)	One copy and one original (max 0.13 mm)	
Paper end	Paper should not be attached to the core	
Ink ribbon specification :		
Color	Black and red	
Ribbon material	Nylon (#40 denier)	
Ribbon size	13mm × 6m	
Spool	13mm (width), 35mm in diameter (two spool)	
Recommended ribbon	SF-03BR	
Operating conditions :		
	Temperature	+5 °C to +40 °C
	Humidity	10% to 80%RH
Storage conditions :		
	Temperature	-20 °C to +70 °C
	Humidity	5% to 95%RH (+40 °C)
Head life :	70 million characters	
Printer reliability :	5.0 million lines MCBF (except head life)	

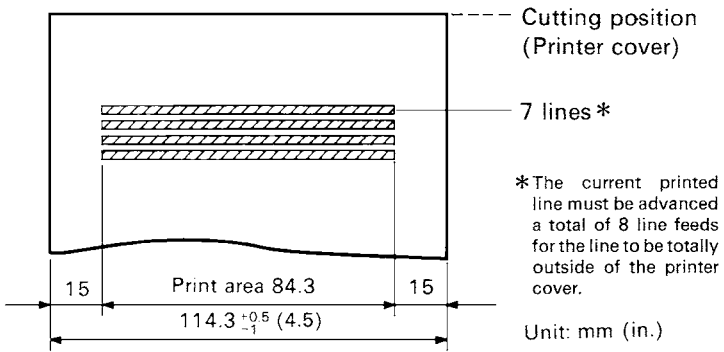


Figure 6-1. Roll Paper and Print Area [Model DP8340F]

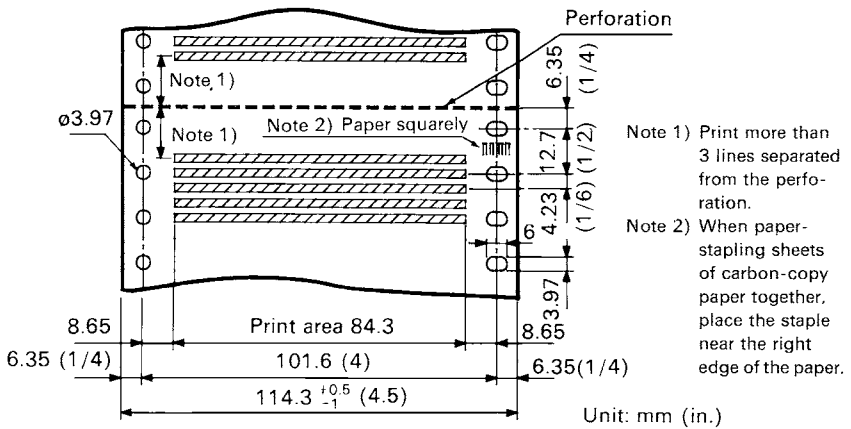
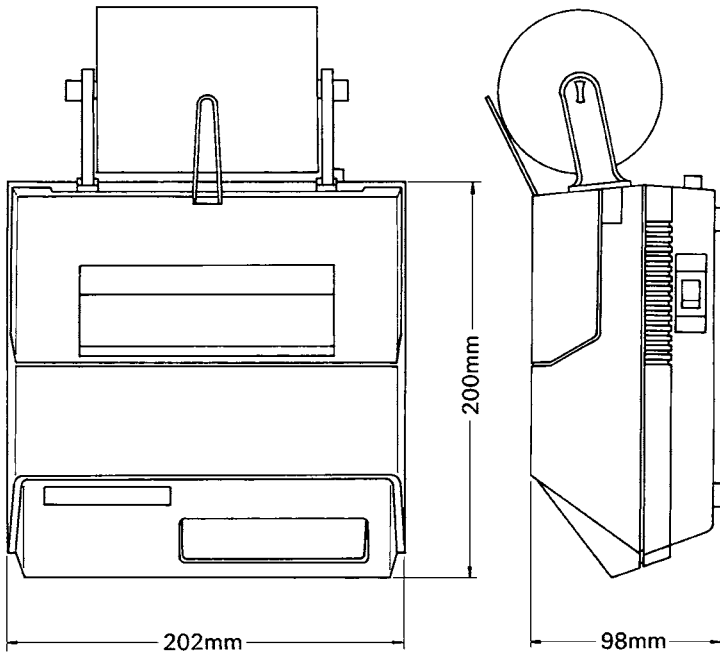
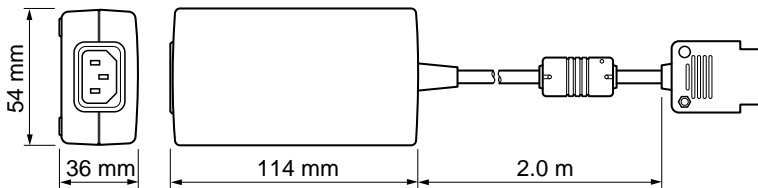


Figure 6-2. Sprocket-feed Paper and Print Area [Model DP8340S]



**Figure 6-3. External Dimensions (Printer)**



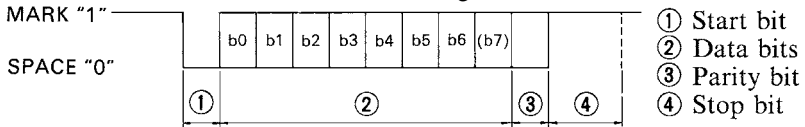
Shape of AC Power plug will vary according to destinations.

**Figure 6-4. External Dimensions (Power Supply Unit)**

# 7. INTERFACE FOR MODEL DP8340-M (MODULAR JACK CONNECTOR)

## 7-1. Interface Specifications

- (1) Synchronization system : Asynchronous
- (2) Baud rate : 150, 300, 600, 1200, 2400, 4800, 9600 bps  
(Selectable)
- (3) Word length :
  - Start bit : 1 bit
  - Data bit : 7 or 8 bits (Selectable)
  - Parity bit : Odd, Even, or None (Selectable)
  - Stop bit : 1 or 2 bit length (Selectable)
- (4) Signal polarity :
  - RS-232C MARK : Logic "1" (-3V to -25V)
  - SPACE : Logic "0" (+3V to +25V)

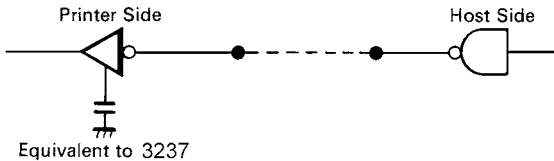


- (5) Handshaking :
  - 1 DTR Mode (1 block)
  - 2 X-ON/X-OFF Mode
  - 3 STX-ETX Mode

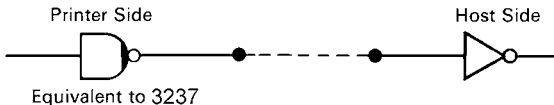
**Note:** STX-ETX Mode may use DTR or X-ON/X-OFF, selected by DIP SW 1-5. See Chapter 9. for details.

## 7-2. Interface Circuit

Input (RXD, CTS)



Output (DTR,  $\overline{\text{FAULT}}$ , TXD, RTS)



**Figure 7-1. RS-232C Interface**



## 7-3. Setting of the DIP Switches

### 7-3-1. DIP-SW 1

Switch	ON	OFF	Factory setting
1-1	Data transfer rate — see below (*1)		ON
1-2			ON
1-3			ON
1-4	Stop bit 1	Stop bit 2	ON
1-5	DTR MODE (1 BLOCK)	X-ON/X-OFF MODE	ON
1-6	8 data bits	7 data bits	ON
1-7	No parity	Parity checked	ON
1-8	Odd parity	Even parity	ON

(\*1)

Baud rate	SW1-1	SW1-2	SW1-3
150	OFF	OFF	OFF
300	OFF	OFF	ON
600	OFF	ON	OFF
1200	OFF	ON	ON
2400	ON	OFF	OFF
4800	ON	OFF	ON
9600	ON	ON	ON/OFF

(\*2)

Paper type		SW2-3
DP8340F		ON
DP8340S	Single	OFF
	2 copy	ON

### 7-3-2. DIP-SW2

Switch	ON	OFF	Factory setting
2-1	International character set: (1) ON, ON ... U.S.A.      (2) OFF, ON...FRANCE (3) ON, OFF...ITALY      (4) OFF, OFF...GERMANY		ON
2-2			ON
2-3	Paper type — see above (*2)		ON
2-4	CR Invalid	CR Valid	ON

**Note:** DIP switches are only read by the controller at power turn on. DIP switch changes should be made with power off, or after changing switch setting, turn the power off and on again.

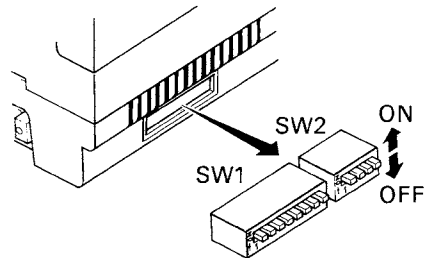
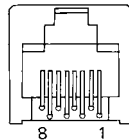


Figure 7-2. Setting of DIP Switch

## 7-4. Connectors and Signals

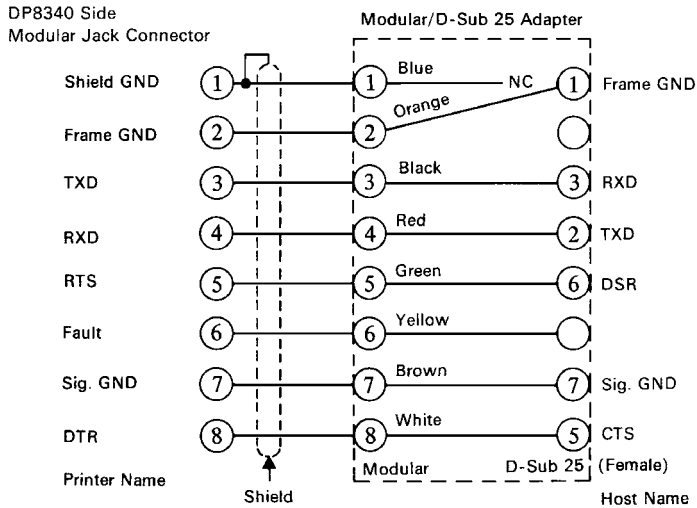
Pin No.	Signal Name	Direction	Function
1	GND	—	Shield Ground
2	GND	—	Frame Ground
3	TXD	OUT	This pin carries data from the printer. (Return channel)
4	RXD	IN	This pin carries data to the printer.
5	RTS	OUT	This is SPACE when the printer power is ON.
6	$\overline{\text{FAULT}}$	OUT	This is MARK when the printer is abnormal. (Machine Error.) Or there is a paper error.
7	GND	—	Signal ground.
8	DTR	OUT	This printer turns this pin SPACE when it is ready to receive data.



**Figure 7-3. Modular Jack Connector**

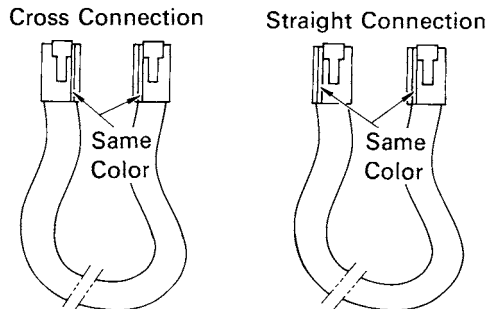
## 7-5. Interface Connections

For interface connections, refer to the instructions for interface of the host computer. The following gives basic examples.

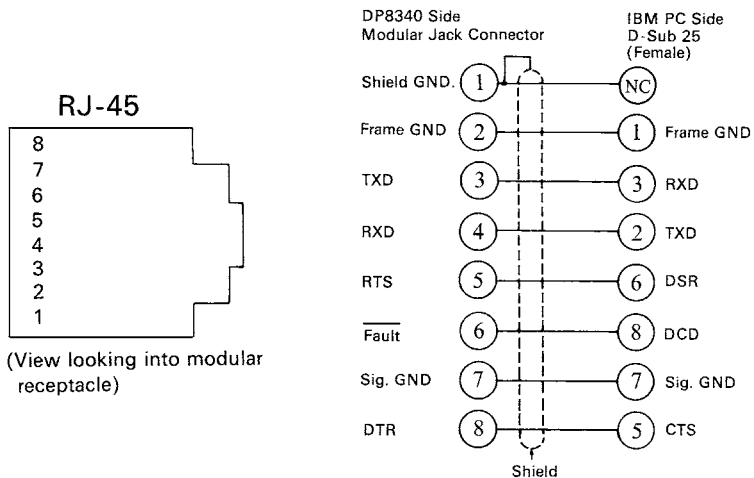


**Figure 7-4. Interface Connections using Modular/D-Sub 25 Adapter to IBM PC  
(Use with straight through cable wiring)**

Before selecting interface cable wiring, it is necessary to know the wiring of the modular interconnect cable. Figure 7-5. below shows the way to determine if the cable is straight connected, or cross connected. Cross connected wiring is not suitable for shielded cable.



**Figure 7-5.**



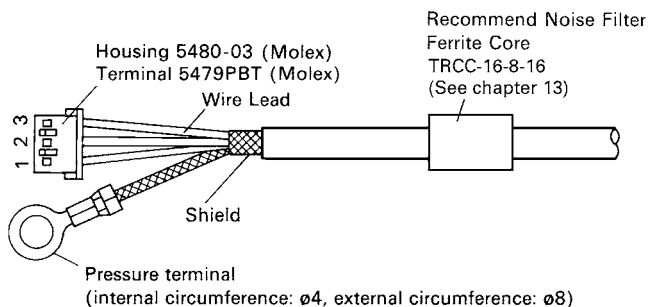
**Figure 7-6. Wiring of cable for direct connection between DP8340 and IBM PC serial part**

## 7-6. Peripheral Unit Drive Circuit

The Control Board of this unit is equipped with a circuit for driving a peripheral unit (Paper Cutter, Take-Up Device, Cash Drawer, etc.)

The Control Board Connector (CN3) is used to connect the Peripheral Unit to the Drive Circuit. When using this circuit connect the peripheral unit cable to the CN3 Connector (cable is not included). Use a cable with the following specifications:

**Note: Do not run cable near devices generating large amounts of electrical noise.**



**Figure 7-7. Cable Specifications**

### 7-6-1. Cable Connection

Remove the printer Bottom Cover and connect the cable to the CN3 Connector. Pass the cable around the control board as shown and through grommetted hole in bottom cover. (Grommet may have to be cut)

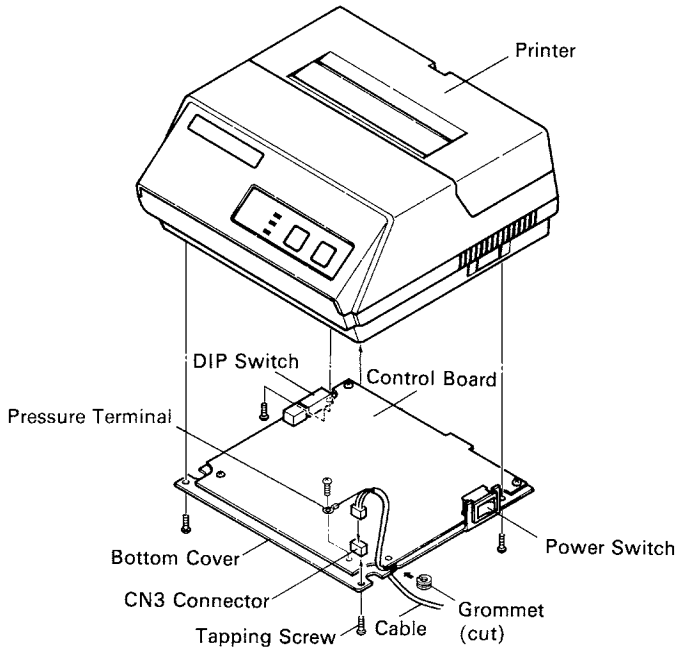


Figure 7-8. Cable Connection

## 7-6-2. Peripheral Drive Circuit

Absolute Ratings (Ta = 25°C)		
D1	Voltage Breakdown	400V
	Peak Forward Current	1A

Drive Output	12V, MAX. 1A
--------------	--------------

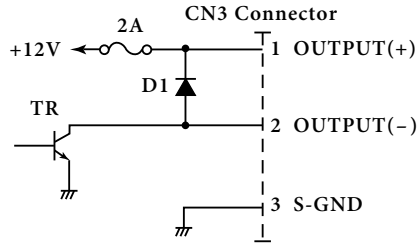


Figure 7-9. Drive Circuit

**Caution:** Do not use external power supply with peripheral drive circuit.

To drive a peripheral unit continuously, set the duty cycle to 20% or less.

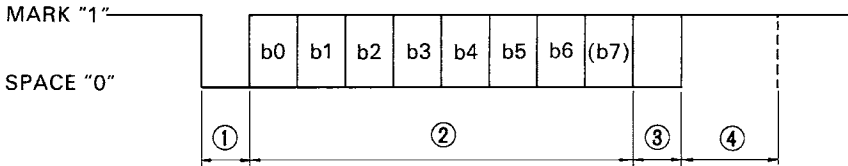
## 7-6-3. Control Codes

Codes for Drive Circuit control are ESC BEL n1 n2, BEL and FS. Refer to the Control Codes in Chapter 5.

# 8. INTERFACE FOR MODEL DP8340-D (D-SUB 25 PIN CONNECTOR)

## 8-1. Interface Specifications

- (1) Synchronization system   Asynchronous
- (2) Baud rate                   150, 300, 600, 1200, 2400, 4800, 9600  
                                      BPS (Selectable)
- (3) Word length
  - Start bit:                   1 bit
  - Data bit:                   7 or 8 bits (Selectable)
  - Parity bit:                 Odd, Even, or None (Selectable)
  - Stop bit:                  1 or 2 bit length (Selectable)
- (4) Signal polarity
  - RS-232C                    MARK   : Logic "1" (-3V to -25V)
  - SPACE   : Logic "0" (+3V to +25V)
  - Current Loop               MARK   : Logic "1" (Current ON)
  - SPACE   : Logic "0" (Current OFF)



- ① Start bit
- ② Data bits
- ③ Parity bit
- ④ Stop bit

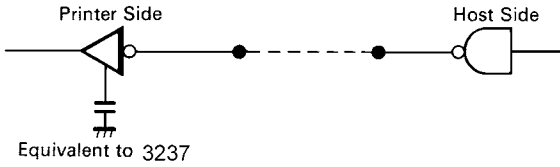
- (5) Handshaking
  - 1 DTR Mode (1 block)
  - 2 X-ON/ X-OFF Mode
  - 3 STX-ETX Mode

**Note:** STX-ETX Mode may use DTR or X-ON/X-OFF, selected by DIP SW 1-5. See Chapter 9. for details.

## 8-2. Interface Circuit

### 8-2-1. RS-232C

Input (RXD, CTS)



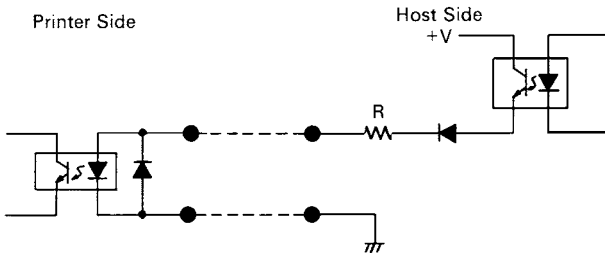
Output (DTR,  $\overline{\text{FAULT}}$ , TXD, RCH, RTS)



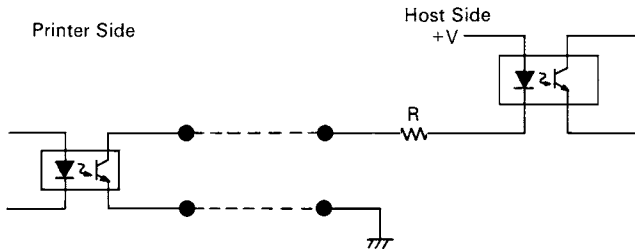
Figure 8-1. RS232-C Interface

### 8-2-2. Current Loop

Input (TTY-RXD, TTY-RXDR)



Output (TTY-TXD, TTY-TXDR)



**Note:** Resistance should be set so that Current Loop is restricted to the range of 10 ~ 20 mA.

Figure 8-2. Current Loop Interface



## 8-3. Setting of the DIP Switches

### 8-3-1. DIP-SW 1

Switch	ON	OFF	Factory setting
1-1	Data transfer rate — see below (*1)		ON
1-2			ON
1-3			ON
1-4	Stop bit 1	Stop bit 2	ON
1-5	DTR MODE (1 BLOCK)	X-ON/X-OFF MODE	ON
1-6	8 data bits	7 data bits	ON
1-7	No parity	Parity checked	ON
1-8	Odd parity	Even parity	ON

(\*1)

Baud rate	SW1-1	SW1-2	SW1-3
150	OFF	OFF	OFF
300	OFF	OFF	ON
600	OFF	ON	OFF
1200	OFF	ON	ON
2400	ON	OFF	OFF
4800	ON	OFF	ON
9600	ON	ON	ON/OFF

(\*2)

Paper type		SW2-3
DP8340		ON
DP8340S	Single	OFF
	2 copy	ON

### 8-3-2. DIP-SW 2

Switch	ON	OFF	Factory setting
2-1	International character set: (1) ON, ON ... U.S.A.      (2) OFF, ON...FRANCE (3) ON, OFF...ITALY      (4) OFF, OFF...GERMANY		ON
2-2			ON
2-3	Paper type — see above (*2)		ON
2-4	CR Invalid	CR Valid	ON

**Note:** DIP switches are only read by the controller at power turn on. DIP switch changes should be made with power off, or after changing switch setting, turn the power off and on again.

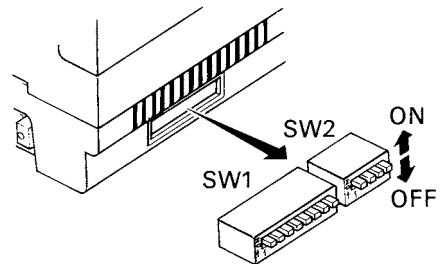


Figure 8-3. Setting of DIP Switch

## 8-4. Jumper Setting

The serial interface is set to the RS-232C mode upon shipment from the factory. When using in the 20mA current loop mode, it is necessary to set the jumpers. The jumpers built into the Control Board allow for setting of functions shown in the table. However, the Bottom Cover must be removed to perform this setting. For setting the Jumper, disconnect the power source beforehand.

### 8-4-1. Removal of the Bottom Cover

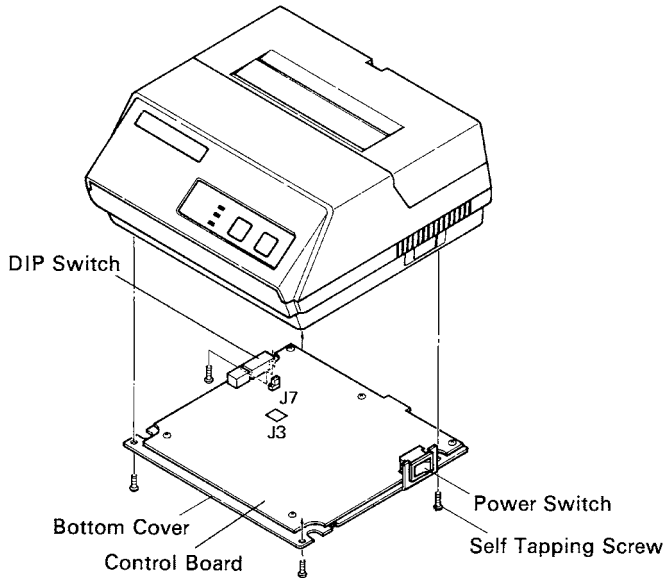


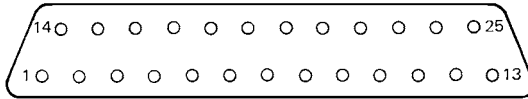
Figure 8-4. Removal of the Bottom Cover

### 8-4-2. Setting of Jumper

Jumper No.	Setting		Function	Factory Setting
J3	OPEN		RS-232C	○
	SHORT	Cut  Solder	Current Loop	
J7	A-C		Selection of Current Loop Output (between TTY-TXD and TTY-TXDR) Signal Polarity (inversion possible) Consult STAR MICRONICS for details.	○
	B-C			

## 8-5. Connectors and Signals

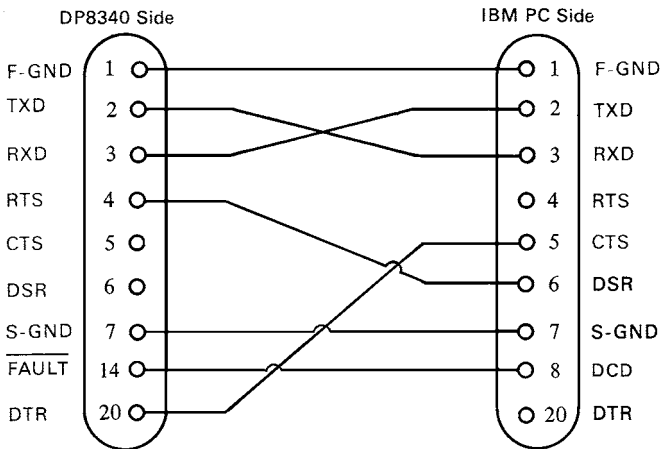
Pin No.	Signal Name	Direction	Function
1	GND	—	Frame Ground
2	TXD	OUT	This pin carries data from the printer. (Return channel)
3	RXD	IN	This pin carries data to the printer.
4	RTS	OUT	This is SPACE when the printer power is ON.
5	CTS	IN	This pin is SPACE when the computer is ready to send data. The printer does not check this pin.
6	DSR	IN	This pin is SPACE when the computer is ready to send data. The printer does not check this pin.
7	GND	—	Signal ground.
8	N/C		Unused.
9	TTY TXDR	—	This pin is the return path for data transmitted from the printer on the 20mA current loop.
10	TTY TXD	OUT	This pin carries data from the printer on the 20mA current loop.
11	RCH	OUT	This pin is SPACE when the printer is ready to receive data. This line carries the same signal as pin 20.
12	N/C		Unused.
13	GND	—	Signal ground.
14	$\overline{\text{FAULT}}$	OUT	This is MARK when the printer is abnormal. (Machine Error.) Or there is a paper error.
15 ~ 16	N/C		Unused.
17	TTY TXDR	—	This pin is the return path for data transmitted from the printer on the 20mA current loop.
18	TTY RXDR	—	This pin is the return path for data transmitted to the printer on the 20mA current loop.
19	TTY RXD	IN	This pin carries data to the printer on the 20mA current loop.
20	DTR	OUT	This printer turns this pin SPACE when it is ready to receive data.
21 ~ 22	N/C		Unused.
23	TTY RXDR	—	This pin is the return path for data transmitted to the printer on the 20mA current loop.
24	TTY TXD	OUT	This pin carries data from the printer on the 20mA current loop.
25	TTY RXD	IN	This pin carries data to the printer on the 20mA current loop.



**Figure 8-5. D-Sub 25 Pin Connector**

## 8-6. Interface Connections

For interface connections, refer to the instructions for interface of the host computer. The following gives one basic example of connections.



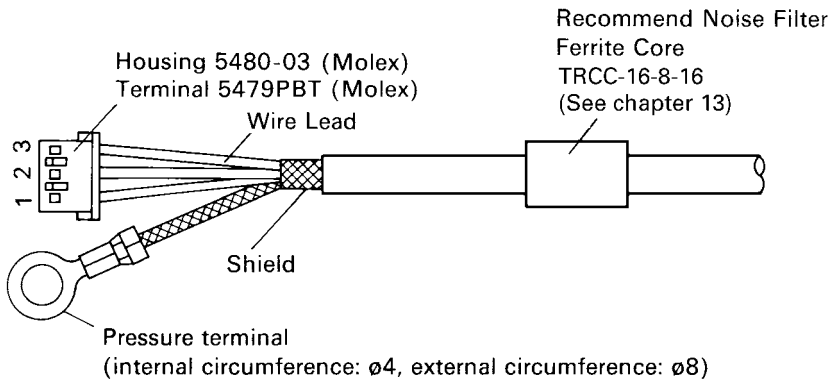
**Figure 8-6. Interface Connections with D-Sub 25 Pin Connector to IBM PC**

## 8-7. Peripheral Unit Drive Circuit

The Control Board of this unit is equipped with a circuit for driving a peripheral unit (Paper Cutter, Take-Up Device, Cash Drawer, etc.)

The Control Board Connector (CN3) is used to connect the Peripheral Unit to the Drive Circuit. When using this circuit connect the peripheral unit cable to the CN3 Connector (cable is not included). Use a cable with the following specifications:

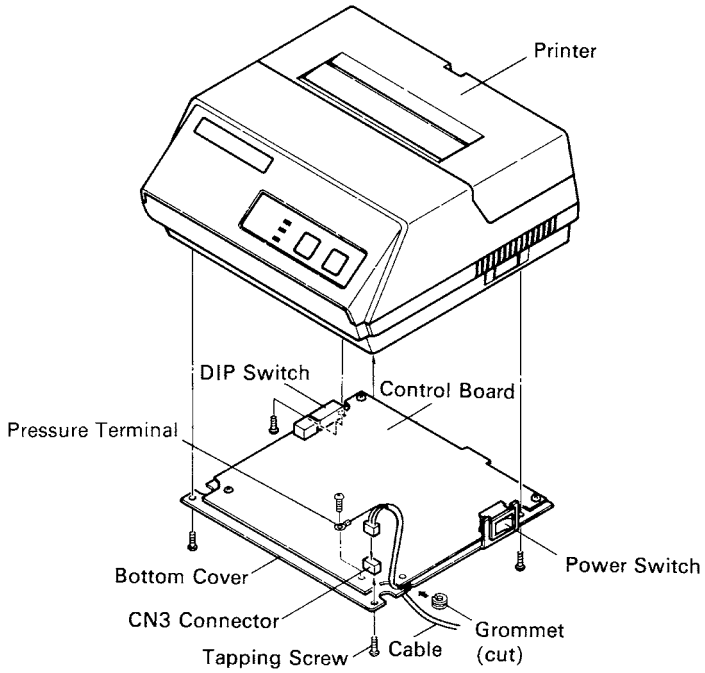
**Note: Do not run cable near devices generating large amounts of electrical noise.**



**Figure 8-7. Cable Specifications**

### 8-7-1. Cable Connection

Remove the printer Bottom Cover and connect the cable to the CN3 Connector. Pass the cable around the control board as shown and through grommetted hole in bottom cover. (Grommet may have to be cut)



**Figure 8-8. Cable Connection**

## 8-7-2. Peripheral Drive Circuit

Absolute Ratings (Ta = 25°C)		
D1	Voltage Breakdown	400V
	Forward Current	1A

Drive Output	12V, MAX. 1A
--------------	--------------

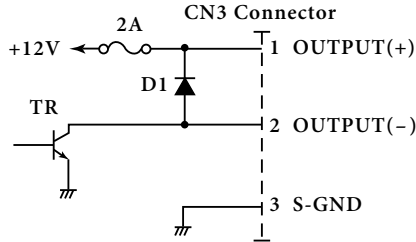


Figure 8-9. Drive Circuit

**Caution:** Do not use external power supply with peripheral drive circuit.

To drive a peripheral unit continuously, set the duty cycle to 20% or less.

## 8-7-3. Control Codes

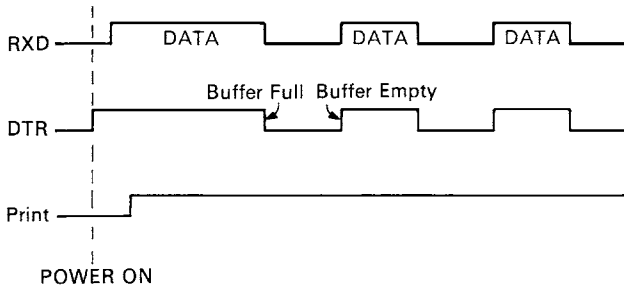
Codes for Drive Circuit control are ESC BEL n1 n2, BEL and FS. Refer to the Control Codes in Chapter 5.

# 9. DATA STRUCTURE AND CONTROL

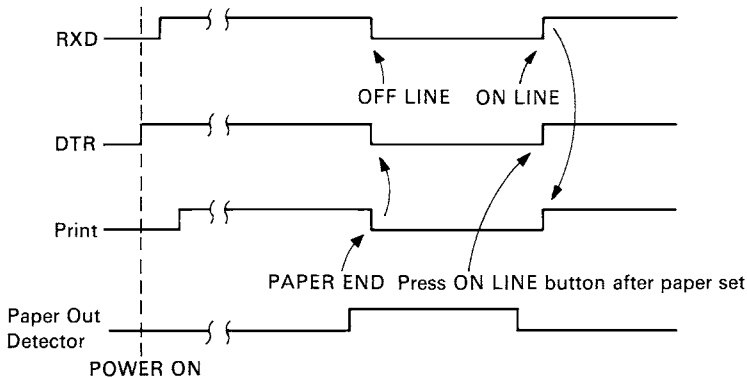
## 9-1. DTR Mode (1 BLOCK)

Controls Data Transfer by using DTR line as BUSY FLAG

(a)



(b) In case of Paper Empty



### Paper Empty

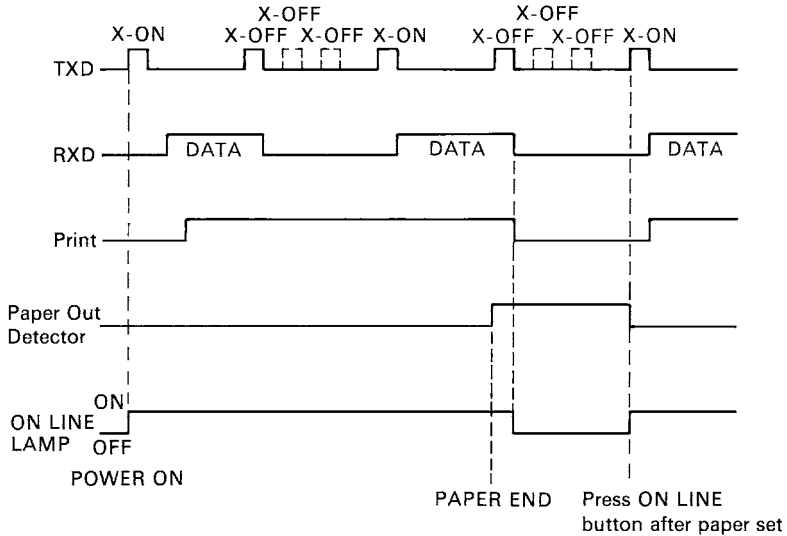
When the paper out detector indicates end of paper, the printer stops printing after a maximum of two lines of printing or paper feed. The printer goes OFF LINE and sets the DTR to "MARK" status immediately after occurrence of a paper empty. It is necessary to install paper into the printer and press the ON LINE BUTTON to light the ON LINE LAMP in order to recover from paper empty status.

### Machine Error

A machine error may be generated by paper jamming or when the printer is unable to print data. When a machine error occurs the printer stops printing. The printer goes OFF LINE and sets the DTR to "MARK" status immediately after the occurrence of Machine Error. It is necessary to turn the printer power off and on again in order to recover from Machine Error.



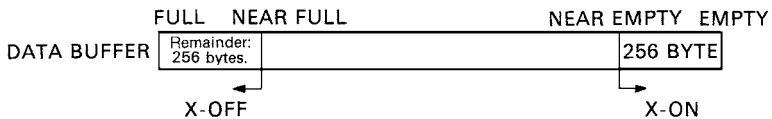
## 9-2. X-ON/X-OFF Mode



The printer transmits an X-ON (Control Code; DC1, Hexadecimal Value; 11H,) signal after power is turned on, if there is no printer error being generated. When this signal is received by the host computer, the host computer transmits the data to the printer. The X-ON signal is output intermittently every three seconds until the host computer receives and responds to this signal.

The X-OFF (DC3, 13H) signal outputting begins when the amount of empty space in the buffer becomes less than 256 bytes. When the computer receives the X-OFF signal, it will halt data transmission as soon as it can. However even at this time the printer can receive data until the buffer is completely full. An X-ON signal is output when the contents of the buffer goes below 256 bytes. The increase of the empty area in the buffer is caused by printing. If the computer causes a buffer overflow, a flag bit in the status register will be set. (See Status)

The X-OFF signal will continue to be output at a 3-second interval until the data buffer becomes near empty (less than 256 bytes).



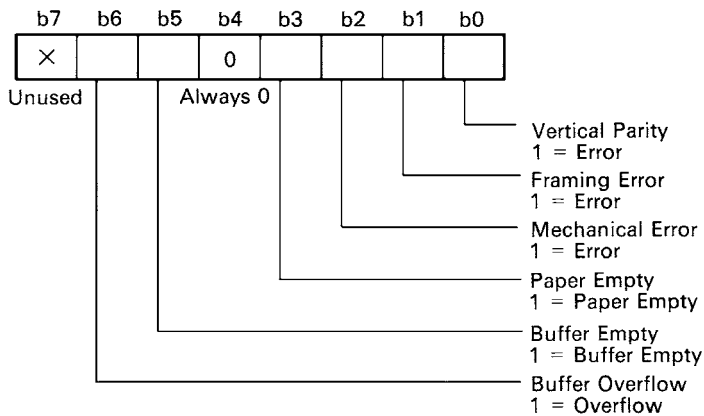
## Paper Empty

When the paper out detector indicates end of paper, the printer stops printing after a maximum of two lines of printing or paper feed. The host computer can receive the printer status by transmitting an ENQ code to the printer. The printer goes OFF LINE and sets the DTR to "MARK" status in 5 seconds after occurrence of a paper empty. It is necessary to install paper into the printer and press the ON LINE BUTTON to light the ON LINE LAMP in order to recover from paper empty status.

## Machine Error

A machine error may be generated by paper jamming or when the printer is unable to print data. When a machine error occurs the printer stops printing. In the X-ON/X-OFF mode, the printer outputs an X-OFF signal immediately. At this time the host computer can receive the printer status after transmitting an ENQ code to printer. The printer goes OFF LINE and sets the DTR to "MARK" status within 5 seconds after the occurrence of Machine Error. It is necessary to turn the printer power off and on again in order to recover from Machine Error.

## STATUS



## Parity

In DTR mode and X-ON/X-OFF mode parity check is done on vertical parity only.

## Framing Error

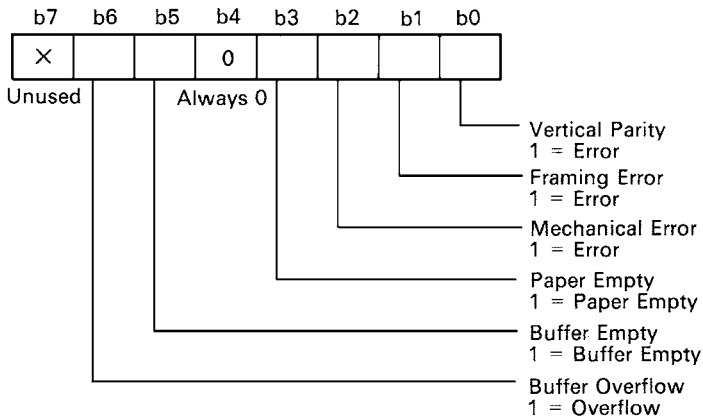
Framing Error occurs when SPACE signal is detected at STOP Bit time. Framing error and vertical parity error will be indicated by printing "?".

### 9-3. STX-ETX Mode

The start of the STX-ETX mode should occur with a totally empty print buffer. This can be achieved by sending an ENQ code to the printer and checking the status until the status code indicates an empty buffer. At that point, the STX code is sent by the host computer followed by a data block. While receiving the data block, the printer generates a horizontal parity check character. After the data block is sent, the host computer sends an ENQ which causes the printer to return 2 characters, one would be the normal status character, and the second would be the horizontal parity check character that was generated by the printer while the data block was received.

The host computer checks the status character to determine if any vertical parity errors or other errors occurred during block transmission, and checks the horizontal parity character against a character generated in the host computer while the data was transmitted. If there are no errors, ETX causes the buffer to be printed, but if an error is detected, CAN code clears the buffer and the data is transmitted again. Any control codes transmitted to the printer during the STX-ETX mode will be ignored as control codes, but will be included in the check character. This is done to prevent a control code received in error from causing printing of erroneous data.

#### STATUS

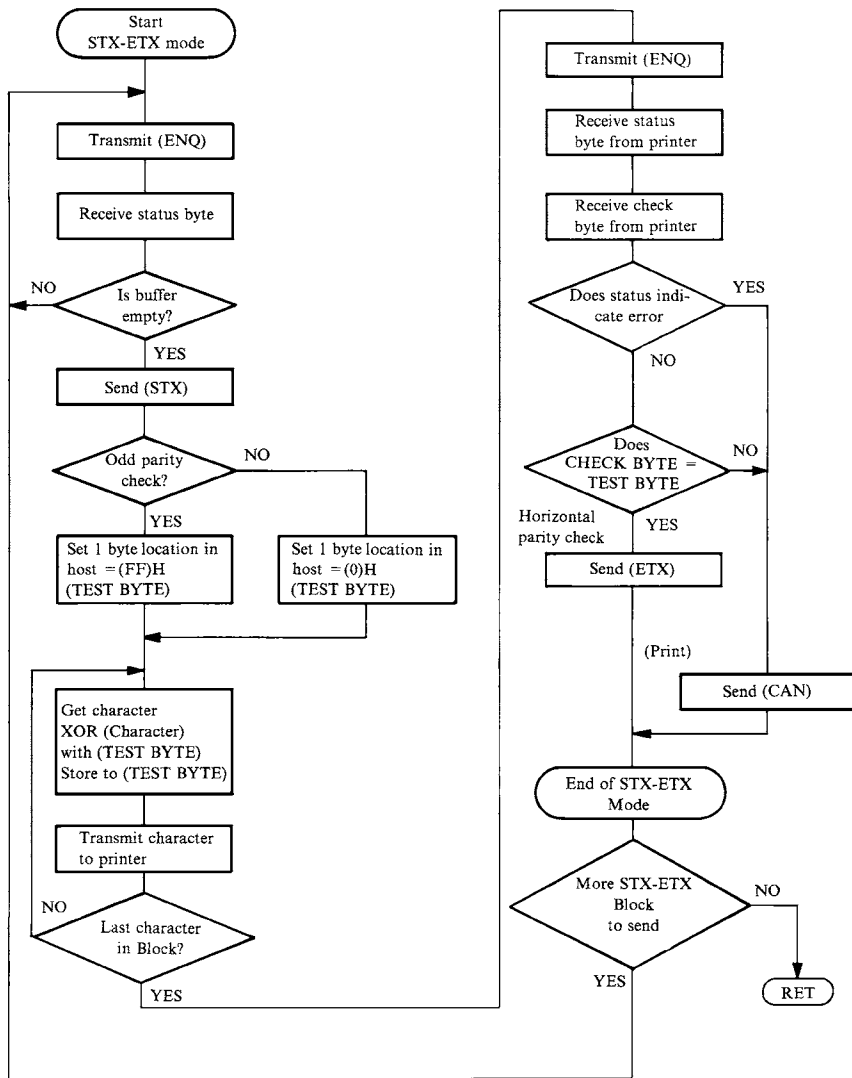


#### Parity

Vertical and horizontal parity check is executed in STX-ETX mode.

#### Framing Error

Framing Error occurs when SPACE signal is detected at STOP Bit time. Framing error or even vertical parity error will be indicated by printing “?”.



CHECK BYTE  
 : Horizontal parity on printer  
 TEST BYTE  
 : Horizontal parity on computer

STX-ETX Mode Flow Diagram

# 10. CHARACTER CODE LIST

Hexa- decimal	0	1	2	3	4	5	6	7
0	0	16	SP 32	0 48	@ 64	P 80	' 96	p 112
1	1	DC1 17	! 33	1 49	A 65	Q 81	a 97	q 113
2	STX 2	DC2 18	" 34	2 50	B 66	R 82	b 98	r 114
3	ETX 3	DC3 19	# 35	3 51	C 67	S 83	c 99	s 115
4	4	DC4 20	\$ 36	4 52	D 68	T 84	d 100	t 116
5	ENQ 5	21	% 37	5 53	E 69	U 85	e 101	u 117
6	6	22	& 38	6 54	F 70	V 86	f 102	v 118
7	BEL 7	23	' 39	7 55	G 71	W 87	g 103	w 119
8	8	CAN 24	( 40	8 56	H 72	X 88	h 104	x 120
9	9	25	) 41	9 57	I 73	Y 89	i 105	y 121
A	LF 10	26	* 42	: 58	J 74	Z 90	j 106	z 122
B	11	ESC 27	+ 43	; 59	K 75	[ 91	k 107	{ 123
C	FF 12	FS 28	, 44	< 60	L 76	\ 92	l 108	 124
D	CR 13	29	- 45	= 61	M 77	] 93	m 109	} 125
E	SO 14	30	. 46	> 62	N 78	^ 94	n 110	~ 126
F	SI 15	31	/ 47	? 63	O 79	_ 95	o 111	⊗ 127

(SP: Space)

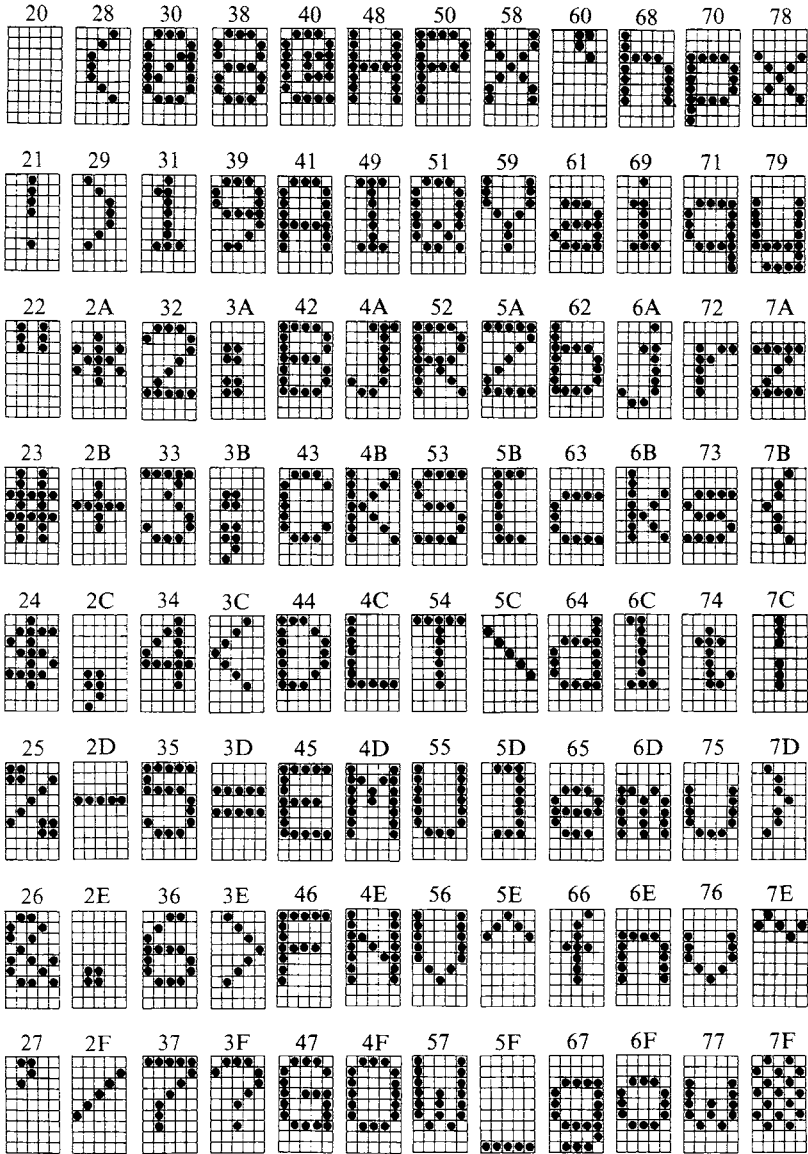
Hexa- decimal	8	9	A	B	C	D	E	F
0	SP 128	┘ 144	Ä 160	é 176	ù 192	ā 208	■ 224	┐ 240
1	┘ 129	┘ 145	Ö 161	è 177	û 193	â 209	▬ 225	▬ 241
2	▬ 130	■ 146	Û 162	ē 178	û 194	° 210	▬ 226	▬ 242
3	┘ 131	■ 147	β 163	ê 179	ϣ 195	°C 211	■ 227	▬ 243
4	▬ 132	■ 148	§ 164	ï 180	ı 196	°F 212	+ 228	┘ 244
5	┘ 133	■ 149	à 165	í 181	Ñ 197	Ω 213	┘ 229	┘ 245
6	▬ 134	┘ 150	ó 166	î 182	ñ 198	μ 214	┘ 230	┘ 246
7	┘ 135	┘ 151	ƒ 167	ï 183	Ē 199	Σ 215	┘ 231	■ 247
8	▬ 136	┘ 152	ç 168	î 184	ó 200	σ 216	■ 232	■ 248
9	┘ 137	┘ 153	½ 169	ö 185	€ 201	x̄ 217	⌘ 233	┘ 249
A	▬ 138	┘ 154	₤ 170	ó 186	Å 202	T <sub>L</sub> 218	┘ 234	┘ 250
B	┘ 139	┘ 155	₧ 171	ò 187	φ 203	X 219	← 235	= 251
C	┘ 140	┘ 156	₣ 172	õ 188	θ 204	∞ 220	↑ 236	 252
D	┘ 141	┘ 157	¼ 173	ô 189	ä 205	± 221	→ 237	┘ 253
E	┘ 142	◆ 158	Ä 174	ü 190	á 206	÷ 222	↓ 238	┘ 254
F	┘ 143	× 159	ë 175	ú 191	â 207	π 223	┘ 239	┘ 255

(SP: Space)

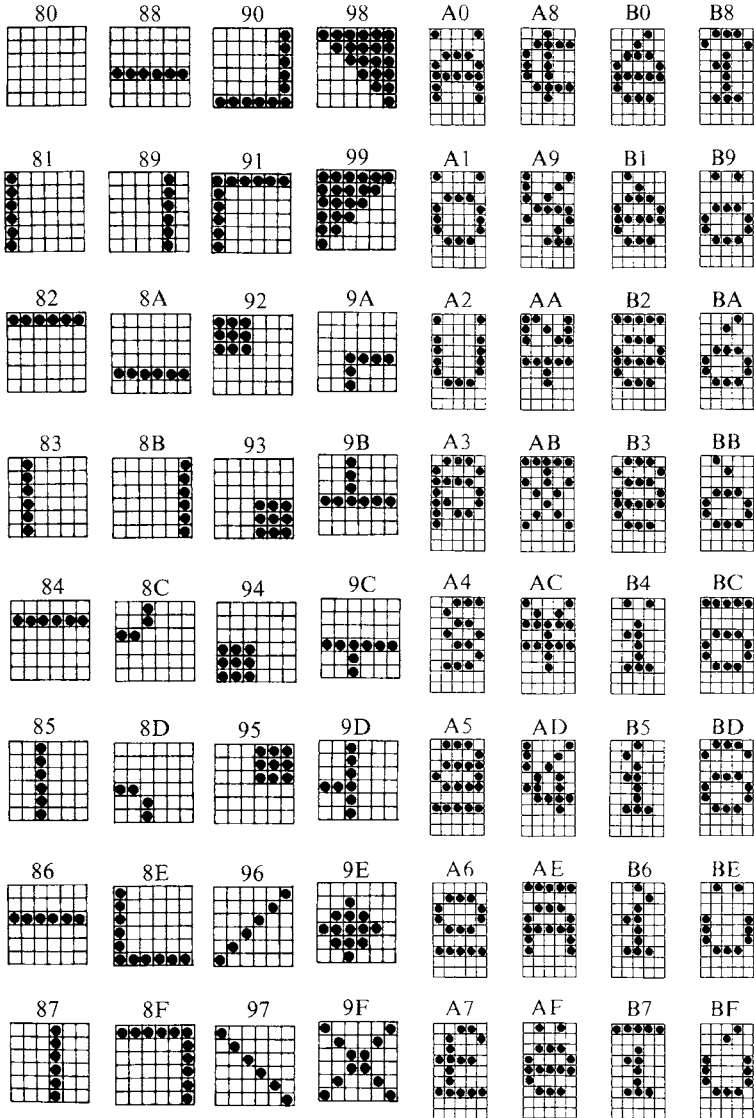
## International Character Sets

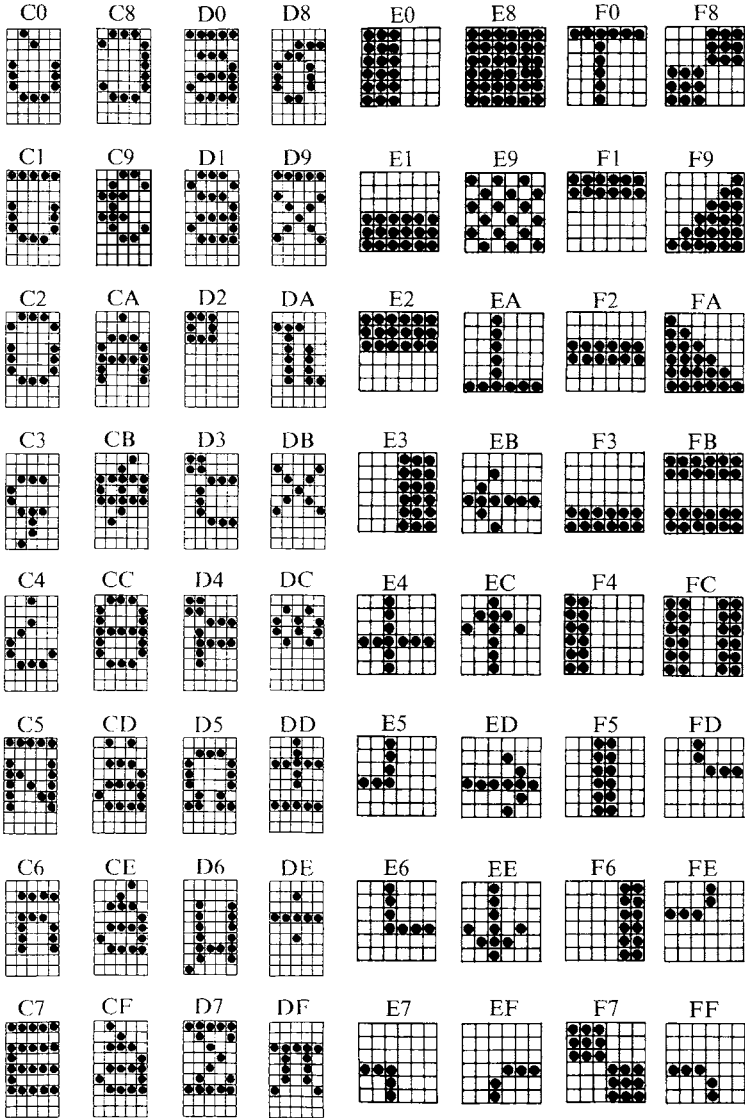
Hexadecimal	23	40	5B	5C	5D	60	7B	7C	7D	7E
U.S.A.	#	@	[	\	]	'	{		}	~
France	f	à	°	ç	§	'	é	ù	è	..
Germany	#	§	Ä	Ö	Ü	'	ä	ö	ü	β
Italy	#	§	°	ç	é	ù	à	ò	è	ì

# 11. FONT LIST

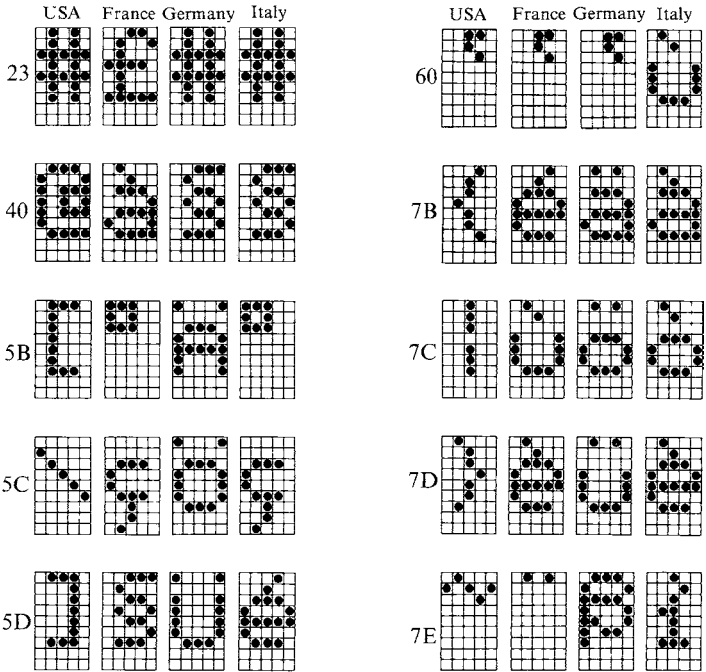








## International Characters



## 12. WHEN POWER IS SUPPLIED BY THE USER

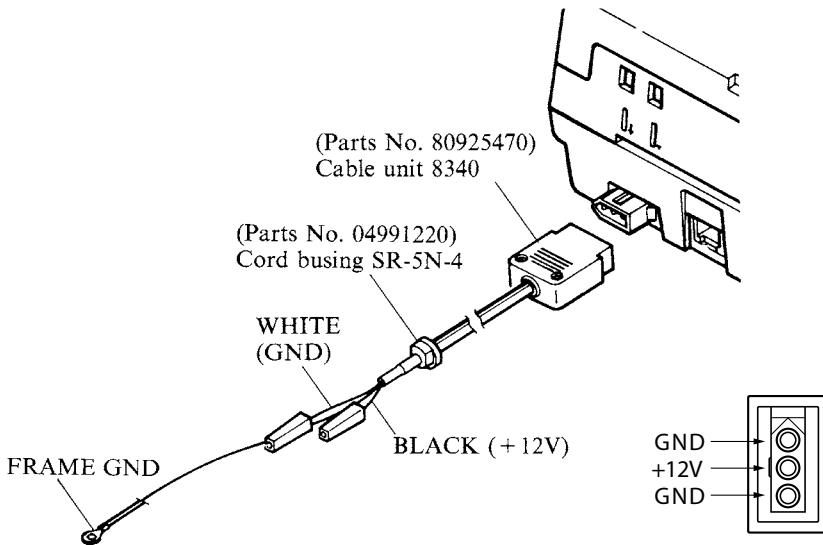
**Note :** The optional AC adapter (PS8340A) has been designed specifically for this unit(DP8340).

Other AC adapters may not meet the EMC technical standards.

When printer power is supplied by the user rather than through the accessory power source unit, please be careful of the following points.

**Note 1:** An electrolytic capacitor ( $C = 4700\mu\text{F}/25\text{V}$  to  $6800\mu\text{F}/25\text{V}$ ) must be connected across the output of the power supply. Use a power supply of DC 12 V  $\pm$  5% and more than 2.0 A with SELV output and LPS or Class 2 (double-insulation structure) output approved by IEC60950.

**Note 2:** A DC power plug is available as an option.



**Note 3:** Be careful about installing the printer in an area where there is noise. Take the appropriate measures to protect against electrostatic AC line noise, etc.

# 13. FERRITE CORE INSTALLATION (EU ONLY)

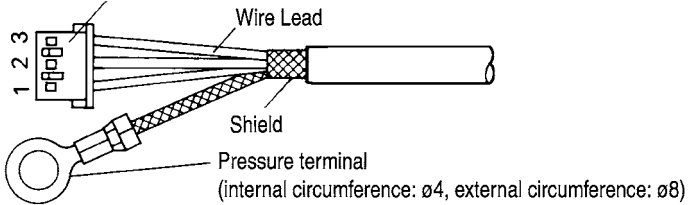
If a peripheral unit drive circuit is to be used, attach a ferrite core using the following instructions.

■ A ferrite core noise filter for the peripheral unit cable comes packed with the printer for distribution throughout the European Union. Ferrite cores must be purchased separately in other areas.

- Cable is not included.
- Use a cable with the following specifications.

Product Code	09990713
Model Name	Ferrite Core TRCC-16-8-16

Housing 5480-03 RED (Molex)  
Terminal 5479PBT (Molex)



■ The ferrite core is normally packed so it is open, as shown in Figure 13-2. If you find that the ferrite core is not open, use a pointed object to pry the plastic lock of the ferrite core apart (Figure 13-1). When you do, take care not to damage the ferrite core or the plastic lock.

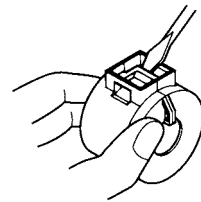


Figure 13-1.

Ferrite core (20mm diameter)

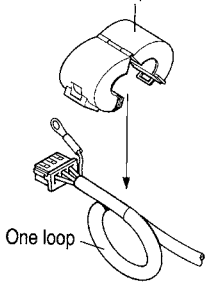
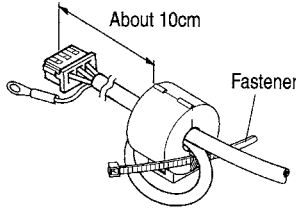
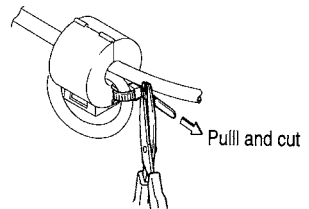


Figure 13-2.



• Pass fastener through ferrite core

Figure 13-3.



• Pass fastener around cable and lock it. Cut off excess with scissors.

Figure 13-4.

- Clamp the ferrite core onto the peripheral unit cable, looping the cable as shown in Figure 13-2.
  - Take care to avoid damaging the cable when installing the ferrite core.
  - The ferrite core should be anchored firmly in place with the fastener that comes with it, as shown in Figures 13-3. and 13-4.
  - Do not forget to loop the cable.
  
- Cable connection

Remove the printer Bottom Cover and connect the cable to the CN3 Connector. Pass the cable around the control board as shown and through grommeted hole in bottom cover. (Grommet may have to be cut)

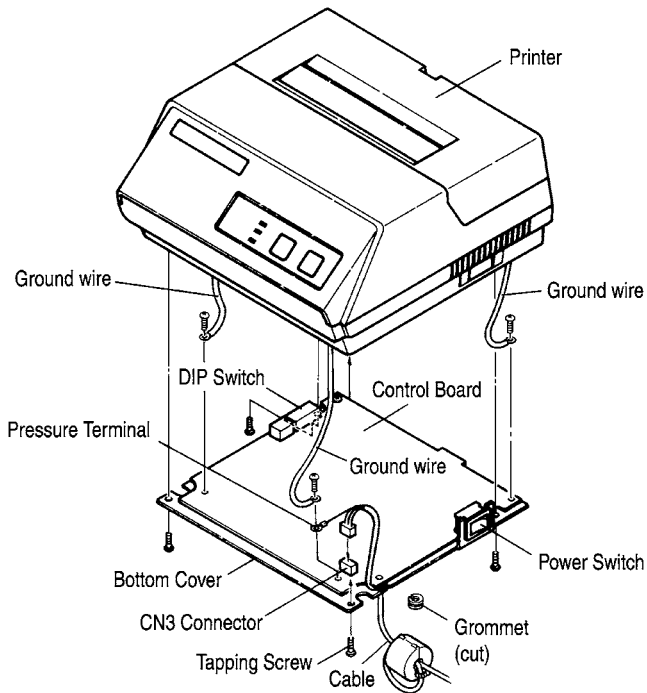


Figure 13-5.



**SPECIAL PRODUCTS DIVISION  
STAR MICRONICS CO., LTD.**

536 Nanatsushinya, Shimizu-ku, Shizuoka,  
424-0066 Japan  
Tel: (int+81)-54-347-0112  
Fax: (int+81)-54-347-0409

Please access the following URL  
<http://www.star-m.jp/eng/dl/dl02.htm>  
for the latest revision of the manual.

**OVERSEAS SUBSIDIARY COMPANIES  
STAR MICRONICS AMERICA, INC.**

1150 King Georges Post Road, Edison, NJ 08837-3729 U.S.A.  
Tel: (int+1)-732-623-5500, Fax: (int+1)-732-623-5590

**STAR MICRONICS EUROPE LTD.**

Star House, Peregrine Business Park, Gomm Road,  
High Wycombe, Bucks, HP13 7DL, U.K.  
Tel: (int+44)-1494-471111, Fax: (int+44)-1494-473333

**STAR MICRONICS ASIA LTD.**

Rm. 1901-5, 19/F., Enterprise Square Two,  
3 Sheung Yuet Road, Kowloon Bay, Hong Kong  
Tel : (int+852)-2796-2727, Fax : (int+852)-2799-9344