



Monitor Touch Screen Elo Touch ET1509L

O ET1509L é o monitor touch screen de 15 polegadas da Elo Touch Solutions com melhor custo benefício. A tela widescreen de LCD é em vidro puro e transparente que oferece uma qualidade de imagem superior.

www.bztech.com.br

Introducing the Elo TouchSystems 1509L Touchmonitor

January 2012



Agenda



- ❖ Overview & Value Proposition
- ❖ Market Opportunity
- ❖ Specifications
- ❖ Installation
- ❖ Part Numbers
- ❖ Things you should know...

Overview and Value Proposition

1509L Main Features



- Size: 15.6" diagonal
- Wide (16:9) aspect ratio touchmonitor
- Very thin consumer-grade LED panel
- Is offered with TE's (bezelled) IntelliTouch SAW touchscreen technology
- VESA/pole-mounting
- One year warranty

Low Price + Great Performance!!!

- Fits slim budgets
 - Available only in EMEA emerging markets, Latin America, greater China only
- Designed to fit tight retail space applications
- The product features the Elo brand recognized for quality and reliability
- The product is built with TE's IntelliTouch touchscreen technology - performing reliably in multiple markets around the world for many years
- Designed for POS applications where space is a premium

Market Opportunity

Advantages of the Elo 1509L

- A high-performing, low-cost alternative to:
 - LCD monitors + “after-market” touch (not built for touch)
 - Elo copies
 - Self-built units (LCD + touch kit)
- Offers the best value for the price
- An attractive, competitive solution for emerging markets

1509L Fits Global Markets

- User guide is available in 10 languages: English, German, Spanish, French, Chinese Simplified, Chinese Traditional, Korean, Japanese, Russian, Arabic, Portuguese **pending???**
- Agency certificates:
 - Australia C-Tick
 - Canada CUL, IC
 - China CCC
 - Europe CE
 - Japan VCCI
 - Kenya KEBS
 - Korea KCC
 - Mexico NOM CoC
 - Nigeria SONCAP
 - Russia GOST
 - Saudi Arabia SASO
 - South Africa SABS
 - Taiwan BSMI
 - United States FCC, UL

Retail



- POS / Retail and Hospitality
- Point-of-Information – in-store information
- Can be attached to the counter
- VESA/pole-mount
- Excellent cable management
- OSD protection
- 12-inch retail space with larger (wide) screen format
 - On-screen keypad
 - More column information
 - Side bar menu

Specifications

1509L Touchmonitor with IntelliTouch Touchscreen Technology

LCD Technology	Active matrix TFT LCD
Diagonal Size	15.6"
Mounting Options	VESA 4-hole 75mm mounting interface on rear of unit See dimensional drawings for details
Native Resolution	1366 x 768
Aspect Ratio	16:9
Number of Colors	16.7 million
Brightness (typical)	LCD Panel: 220 nits with IntelliTouch: 198 nits
Viewing Angle (typical)	Horizontal: $\pm 40^\circ$ Vertical: $+10^\circ, -30^\circ$
Contrast Ratio (minimum)	300
Video	Analog VGA on Female DE-15 connector Input Video Horizontal Sync frequency range: 30 – 80KHz Input Video Vertical Sync (frame rate) frequency range: 60Hz
Backlight Lamp Life (minimum)	12,000 hours to half brightness (consumer-grade panel)
Audio	No audio functionality
Warranty	1 years
MTBF	50,000 hours demonstrated

Installation

Monitor Connectors



- VGA for Video
- USB for touch
 - No serial connection

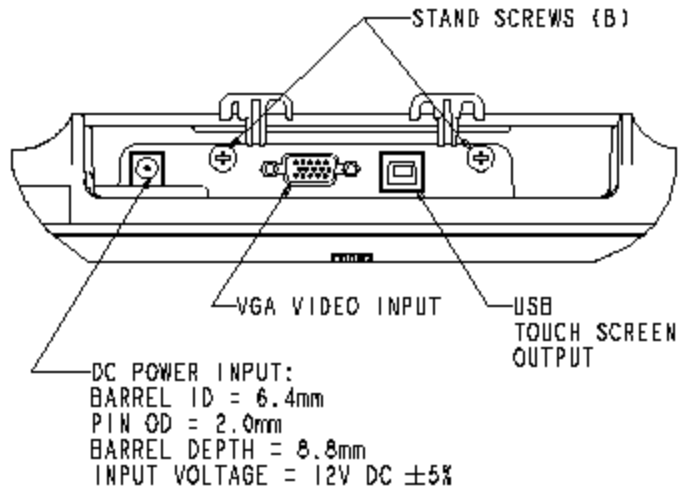

Monitor Power Supply

- External power supply
- AC-DC power adapter included.
 - Clip-on power adapter plugs
 - Standard power connectors for US, EU and China in the box. Additional packs of 100 available

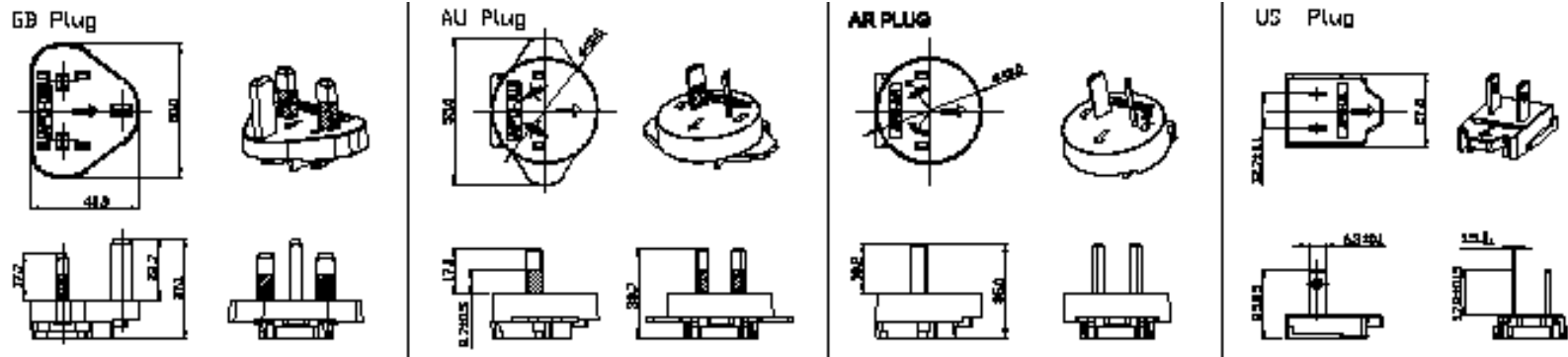

Mounting and Peripherals



- VESA-mount 75x75mm
- Wall-mount with E-series bracket (not a separate PN yet)
- Holes to mount the MSR



M4 THREAD,
MAX. SCREW LENGTH
7mm FROM MOUNTING
SURFACE, X4

PWR. STATUS LIGHT

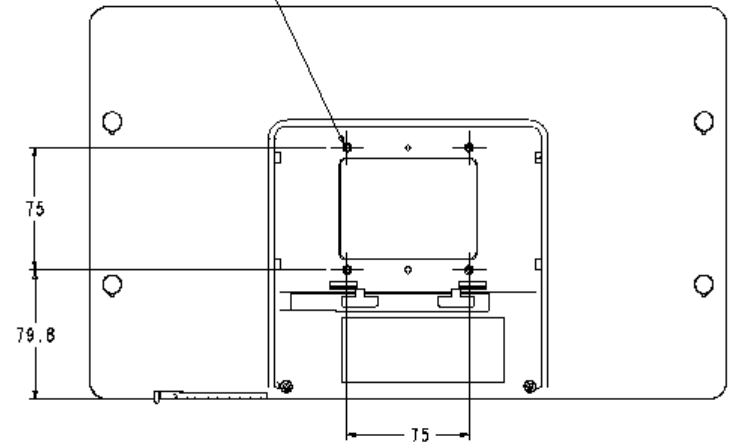

TO REMOVE STAND,
REMOVE STAND SCREWS (A) AND (B)
SHOWN IN LEFT VIEWS.

Part Numbers

1509L Touchmonitor with IntelliTouch Touchscreen Technology

Part Number	Part Description	Touch Technology	Surface Treatment	Touch Interface	Video Interface
E534869	ET1509L-8UWA-0-G	IntelliTouch	Clear	USB	VGA
E757859	Magnetic Stripe Reader (same as 2201L)				
D82064-000	IntelliTouch stylus pen				
E529990	PWR1509L-100PLUGS-UK				
E945226	PWR1509L-100PLUGS- Taiwan				
E415191	PWR1509L-100PLUGS- Japan				
E249003	PWR1509L-100PLUGS- India				
E870572	PWR1509L-100PLUGS- Argentina				

Thank you